



U.S. Department of Justice

Bureau of Alcohol, Tobacco,
Firearms and Explosives

Office of the Director

Washington, DC
20226

18 U.S.C. 921(a)(23): DEFINITIONS (MACHINEGUN)
18 U.S.C. 923(i): IDENTIFICATION OF FIREARMS
26 U.S.C. 5842(a): IDENTIFICATION OF FIREARMS
26 U.S.C. 5845(a): DEFINITIONS (FIREARM)
26 U.S.C. 5845(b): DEFINITIONS (MACHINEGUN)
27 CFR 478.11: DEFINITIONS (FIREARM FRAME OR RECEIVER, MACHINEGUN)
27 CFR 478.92: IDENTIFICATION OF FIREARMS
27 CFR 479.11: DEFINITIONS (FIREARM, FRAME OR RECEIVER, MACHINEGUN)
27 CFR 479.102: IDENTIFICATION OF FIREARMS

The right side-plate of a Vickers/Maxim-type firearm, manufactured with its camming lobe affixed in the proper location, and without an ATF approved block that prevents installation of machinegun fire control components, is a machinegun receiver, and therefore, a machinegun as defined by the Gun Control Act of 1968, 18 U.S.C. 921(a)(23), the National Firearms Act, 26 U.S.C. 5845(b), and their implementing regulations, 27 CFR 478.11 and 479.11. Provided it has not been disassembled into its component parts, a complete Vickers/Maxim-type machinegun that is currently registered in the National Firearms Registration and Transfer Record with its serial number located on a component part of the receiver box other than the right side-plate has been lawfully registered under the National Firearms Act and may be lawfully possessed by the registrant under 18 U.S.C. 922(o).

ATF Rul. 2010-3

The Bureau of Alcohol, Tobacco, Firearms and Explosives (ATF) has received requests for clarification from persons asking what part of Vickers/Maxim-type machineguns constitutes the frame or receiver that must be marked with a serial number and required identifying information and registered in the National Firearms Registration and Transfer Record (NFRTR).

ATF examined various types of Vickers/Maxim-type firearms in both semi-automatic and machinegun configurations. The design of these firearms, in either configuration, consists of forward and rear sections. The forward section is made of a reciprocating barrel assembly. The majority of the barrel assembly is contained inside a jacket. The jacket has a rear ring (often integrally formed with the trunnion), an outer body, and a forward ring or cap. The forward ring incorporates a mounting point for an accelerator and guide for the forward part of the barrel. The rear section is made of the receiver-box, which contains the internal fire control components of the firearm and provides housing for the rear portion of the barrel assembly and the ammunition feed tray. The receiver-box consists of a left and a right side-plate, bottom channel, and trunnion that are held together by a number of rivets. The receiver-box also provides

mounting for the handle block, top cover, and recoil mechanism. Camming lobes, which are permanently affixed to the inside portion of each side-plate, hold the lock piece in place and guide the movement of the extractor, which is attached to the lock piece. Vickers/Maxim-type side-plates are recognizable and properly classified as side-plates for this weapon when the camming lobe has been affixed. The right side-plate of the Vickers/Maxim-type machinegun provides housing for the hammer, breechblock, and firing mechanism, and attaches to the trunnion, which holds the rear portion of the barrel. The right side-plate typically contains a mounting point for the cocking-lever assembly.

ATF evaluated Vickers/Maxim-type firearms and parts in the following configurations:

1. A completely assembled Vickers/Maxim-type firearm;
2. A complete receiver-box;
3. A left side-plate;
4. A right side-plate (both automatic and semi-automatic configurations);
5. A trunnion;
6. A parts kit containing a right side-plate; and
7. A parts kit containing a left side-plate.

During the evaluations, complete, original models of Vickers and German MG-08 Maxim-type machineguns were tested and found to fire automatically more than one round of ammunition by a single function of the trigger. Additionally, a reference model of a Vickers-type machinegun was tested for function; first, by partially removing the right side-plate, and then after completely removing the right side-plate. Although the sample firearm was capable of firing one shot with a partial right side-plate, once the entire right side-plate was removed, testing demonstrated the sample was not capable of functioning without the right side-plate. Accordingly, it was determined that neither a Vickers nor any Maxim-type machinegun would be capable of firing with the entire right side-plate removed. Nonetheless, ATF has previously examined semi-automatic versions of the Vickers/Maxim firearm where the right side-plate has an approved block that prevents installation of machinegun fire control components. These semi-automatic firearms have been classified by ATF as firearms under the Gun Control Act of 1968 (GCA), but not as machineguns under the GCA or the National Firearms Act (NFA).

The NFA, 26 U.S.C. 5845(a)(6), and its implementing regulation, 27 CFR 479.11, define the term firearm, in part, as a machinegun. The term machinegun is defined by the GCA, 18 U.S.C. 921(a)(23), the NFA, 26 U.S.C. 5845(b), and their implementing regulations, 27 CFR 478.11 and 479.11, as any weapon which shoots, is designed to shoot, or can be readily restored to shoot, automatically more than one shot, without manual reloading, by a single function of the trigger. The term shall also include the frame or receiver of any such weapon ... The term frame or receiver is defined in 27 CFR 478.11 and 479.11 as [t]hat part of a firearm which provides housing for the hammer, bolt or breechblock and firing mechanism, and which is usually threaded at its forward portion to receive the barrel.

A completely assembled Vickers/Maxim-type machinegun is a weapon that shoots automatically more than one shot, without manual reloading, by a single function of the trigger. Therefore, a completely assembled Vickers/Maxim-type machinegun is a machinegun as defined by the GCA, 18 U.S.C. 921(a)(23), the NFA, 26 U.S.C. 5845(b), and their implementing regulations, 27 CFR 478.11 and 479.11.

Moreover, though not necessary for classification, only with a complete right side-plate could the Vickers/Maxim-type machinegun shoot automatically more than one shot, without manual reloading, by a single function of the trigger. Therefore, the right side-plate of a Vickers/Maxim-type machinegun, either stand-alone or assembled as part of the complete receiver-box, is a machinegun receiver, and therefore, a machinegun, as defined by the GCA, NFA, and their implementing regulations. The right side-plate of the Vickers/Maxim-type machinegun is illustrated below.

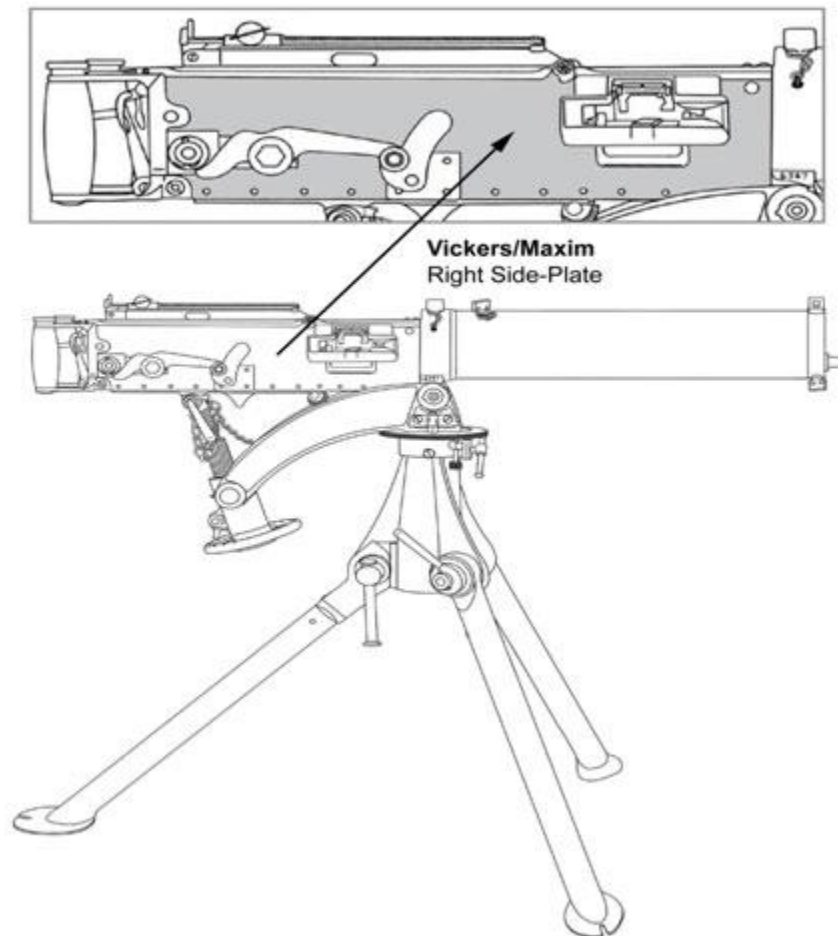

Because the right side-plate of a Vickers/Maxim-type machinegun is the machinegun receiver, any kit or collection of parts of a Vickers/Maxim-type firearm containing the right side-plate is also a machinegun. In contrast, any individual part of a Vickers/Maxim-type firearm other than the machinegun's right side-plate, or any kit or collection of parts of a Vickers/Maxim-type firearm that does not contain the machinegun right side-plate is not a machinegun receiver, and therefore, not a machinegun, as defined by the GCA, NFA, and their implementing regulations.

Machineguns are required to be identified by a serial number, pursuant to 18 U.S.C. 923(i), 26 U.S.C. 5842, 27 CFR 478.92, and 479.102. Under 27 CFR 478.92(a)(1) and (2) and 479.102(a)(1) and (e), the serial number must be placed on the frame or receiver of a machinegun regardless of whether it is part of a complete firearm. Thus, the right side-plate, either unattached or assembled as part of a complete Vickers/Maxim-type machinegun, must be identified with a serial number and registered in the NFRTR.

ATF is aware that, without the benefit of this ruling, some complete Vickers/Maxim-type machineguns registered in the NFRTR were identified with serial numbers located on parts other than the right side-plate. Federal regulations at 27 CFR 478.92(a)(4) and 479.102(c) provide that the Director of ATF may authorize other means of identification of firearms if the other method is reasonable and will not hinder the effective administration of the regulations. Provided that it has not been disassembled into its component parts, ATF finds that a complete Vickers/Maxim-type machinegun identified with a serial

number on a component part of the receiver box other than the right side-plate has been registered in the NFRTR in a manner that will not hinder the effective administration of the NFA or its regulations.

However, if the complete machinegun is disassembled, such as for resale of the right side-plate, the right side-plate must be marked with its registered serial number and name of the manufacturer, as required by 26 U.S.C. 5842(a) and 27 CFR 479.102. If disassembled without its required markings, the unmarked right side-plate of a Vickers/Maxim-type firearm would be a machinegun receiver not identified or registered in the NFRTR, and therefore, unlawful to transfer and possess, pursuant to 18 U.S.C. 922(o) and 26 U.S.C. 5861.

Held, the right side-plate of a Vickers/Maxim-type firearm, manufactured with its camming lobe affixed in the proper location, and without an ATF approved block that prevents installation of machinegun fire control components, is a machinegun receiver, and therefore, a machinegun as that term is defined by the Gun Control Act of 1968, 18 U.S.C. 921(a)(23), the National Firearms Act, 26 U.S.C. 5845(b), and their implementing regulations, 27 CFR 478.11 and 479.11.

Held further, provided it has not been disassembled into its component parts, a complete Vickers/Maxim-type machinegun that is currently registered in the National Firearms Registration and Transfer Record with its serial number located on a component part of the receiver box other than the right side-plate, has been lawfully registered under the National Firearms Act and may be lawfully possessed by the registrant under 18 U.S.C. 922(o).

To the extent this ruling is inconsistent with any prior classifications, they are hereby superseded.

Date approved: September 28, 2010

A handwritten signature in black ink, appearing to read "Ken Melson", written in a cursive style.

Kenneth E. Melson
Deputy Director