



# Laboratory Services Fire Research Laboratory

These are management system documents utilized by ATF Laboratories. They are provided for informational purposes only. Sensitive or copyrighted information has been redacted. The documents are used in ATF Laboratories and not published with the intent of setting a policy or analysis standard for other laboratories. The inclusion of product names does not imply endorsement by ATF Laboratories.

These documents are current as of August 20, 2025. ATF management system documents are reviewed annually and revised as needed. For specific requests, submit a Freedom of Information Act (FOIA) request. Instructions on how to file a FOIA request are found at: [www.atf.gov/resource-center/freedom-information-act-foia](http://www.atf.gov/resource-center/freedom-information-act-foia).

## INDEX

ATF-LS-FRL Codes and Standards  
ATF-LS-FRL Combustion Calorimeter - Standard Operating Procedures  
ATF-LS-FRL Commissioning Documentation Requirements  
ATF-LS-FRL Computer Modeling  
ATF-LS-FRL Cone Calorimeter – Standard Operating Procedures  
ATF-LS-FRL Differential Pressure - Averaging Velocity Probes - Standard Operating Procedure  
ATF-LS-FRL Differential Pressure - Point Velocity Probes - Standard Operating Procedure  
ATF-LS-FRL Digital Camera - Standard Operating Procedures  
ATF-LS-FRL Engineering - Examinations of Items  
ATF-LS-FRL Engineering - Leak and Flow Testing  
ATF-LS-FRL Engineering - Scene Examinations  
ATF-LS-FRL Engineering - Smoke Alarm Evidence Examinations  
ATF-LS-FRL Engineering Activities  
ATF-LS-FRL Engineering Calculations  
ATF-LS-FRL FireTOSS Calculation Documentation Requirements  
ATF-LS-FRL Handling of Items Containing Lithium Batteries and Cells  
ATF-LS-FRL Heat Flux Transducer - Standard Operating Procedures  
ATF-LS-FRL Hot Wire Anemometer - Standard Operating Procedures  
ATF-LS-FRL Laboratory Conditions - Standard Operating Procedures



# Laboratory Services Fire Research Laboratory

ATF-LS-FRL Sand Burner and Gas Cart - Standard Operating Procedures  
ATF-LS-FRL Sartorius Scale-150 kg-Standard Operating Procedure  
ATF-LS-FRL Sartorius Scale-30 kg-Standard Operating Procedure  
ATF-LS-FRL Sartorius Scale-450 kg - Standard Operating Procedures  
ATF-LS-FRL Servomex 4100 Gas Analysis Rack - Standard Operating Procedures  
ATF-LS-FRL Servomex Gas Analyzer Functional Verification - Standard Operating Procedures  
ATF-LS-FRL Siemens Gas Analysis Cart- Standard Operating Procedures  
ATF-LS-FRL Stopwatch - Standard Operating Procedures  
ATF-LS-FRL Technical Research  
ATF-LS-FRL Thermocouple - Standard Operating Procedures  
ATF-LS-FRL Tube Burner - Standard Operating Procedures  
ATF-LS-FRL-Fire Product Collectors - Standard Operating Procedures  
ATF-LS-FRL-FPC Laser Optical Density Meter - Standard Operating Procedures  
ATF-LS-FRL-FPC White Light Optical Density Meter - Standard Operating Procedures ATF-  
LS-FRL-LI001 Thermocouple  
ATF-LS-FRL-LI002 Heat Flux Transducer  
ATF-LS-FRL-LI003 Digital Cameras  
ATF-LS-FRL-LI007 Stopwatch  
ATF-LS-FRL-LI009 Velocity - Differential Pressure  
ATF-LS-FRL-LI010 Calibration Burners  
ATF-LS-FRL-LI011 Fire Products Collectors  
ATF-LS-FRL-LI014 - Optical Density Meter  
ATF-LS-FRL-LI015 Velocity-Hot Wire Anemometers  
ATF-LS-FRL-LI016 Point Source Gas Analysis  
ATF-LS-FRL-LI017 Laboratory Conditions  
ATF-LS-FRL-LI018 Combustion Calorimeter  
ATF-LS-FRL-LI019 Weighing Devices  
ATF-LS-FRL-TR009a Differential Pressure - Point Velocity Probes



# Laboratory Services Fire Research Laboratory

ATF-LS-FRL-TR009b Differential Pressure - Averaging Velocity Probes

ATF-LS-FRL-TR010A Sand Burners and Gas Carts

ATF-LS-FRL-TR010B Tube Burner

ATF-LS-FRL-TR011a - Fire Products Collectors - 1 MW Square

ATF-LS-FRL-TR011b - Fire Products Collectors - 1 MW Round

ATF-LS-FRL-TR011c - Fire Products Collectors - 4 MW

ATF-LS-FRL-TR014A-Optical Density Meter Fire Product Collector

ATF-LS-FRL-TR016A Servomex 4100 Gas Purity Analyzer

ATF-LS-FRL-TR016B Siemens Oxymat 61

ATF-LS-FRL-TR016C Siemens Ultramat 23

ATF-LS-FRL-TR019B Sartorius Scale-450 kg - Technical Reference

ATF-LS-FRL-TR019I Sartorius Scale-30 kg - Technical Reference

ATF-LS-FRL-TR019J Sartorius Scale-150 kg - Technical Reference



ATF-LS-FRL Codes and Standards	ID: 1552 Revision: 5
Authority: Technical Leader	Page: 1 of 3
Original maintained by Quality Programs; copies are uncontrolled.	

**1. Title:** Procedure for use of Codes and Standards

**2. Scope:**

**2.1** This procedure provides the approach for the use of Codes by the Fire Research Laboratory (FRL), including but not limited to Building Codes, Electrical Codes, Fire Protection Codes and Life Safety Codes.

**3. Description:**

**3.1** Codes may be used for a variety of applications in the FRL. This may include:

- 3.1.1** determining whether a building or item met applicable regulations when it was built/manufactured,
- 3.1.2** providing guidance to Certified Fire Investigators that have code-related questions,
- 3.1.3** and using prescriptive codes to help provide input to calculations and computer models when a generic value representative of something that may be expected to be found in the field is required.

**3.2** While the use of prescriptive codes will at times present an engineer with several options, they are generally fairly specific in their requirements and require very little in the way of decisions that may affect an analysis. At times when the information prescribed by the code is either open-ended or vague the engineer should check with the authority having jurisdiction to determine whether there have been interpretations or clarifications of the issue. These are often available either via the jurisdiction's website or in handbooks for the model codes.

**3.3** For each application of codes, the engineer should verify that they have obtained the appropriate code for the case. While many jurisdictions have similar codes, most have their own amendments that need to be incorporated into any analysis; in addition, the relevant edition of the code should be verified, as it is not always appropriate to default to the most recent edition of the code. When codes are used the name of the code and the year of its publication should be noted, as well as the presence (or lack thereof) of any local amendments.

**4. Uncertainty:**

Due to the nature of prescriptive code analysis, there is generally not a way in which uncertainty can be measured in a quantitative fashion. Where code-related decisions are made that are unclear or could be interpreted in several ways, an appropriate reference or explanation for the decision should be provided in the documentation.

**5. Procedure:**

**5.1** The procedure for the use of codes is as indicated in the flow chart below.



ATF-LS-FRL Codes and Standards	ID: 1552 Revision: 5
Authority: Technical Leader	Page: 2 of 3
Original maintained by Quality Programs; copies are uncontrolled.	

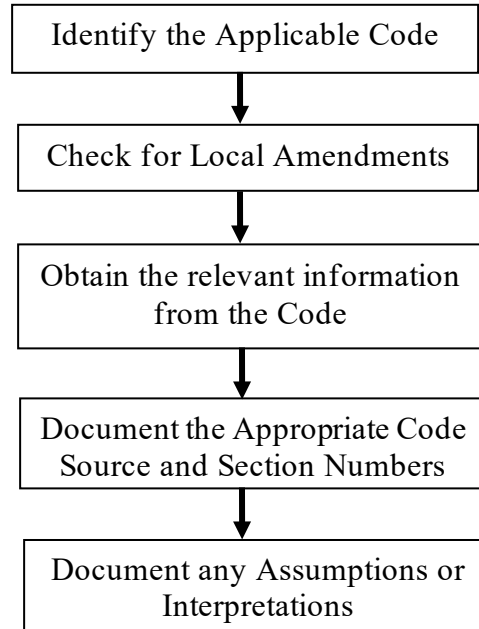

**Figure 1. Procedure for the use of codes**

**5.2** The procedural steps for the use of Codes (as illustrated in the flow chart above) are as follows:

*Step 1 – Identify the Applicable Code:*

To determine the current applicable version of the code and to find local amendments the local jurisdiction should be contacted. Often the FRL will need to reference older editions of codes for existing buildings or products. Information regarding which codes were applicable at earlier dates are often available from the local jurisdiction.

*Step 2 – Check for Local Amendments:*

Although many jurisdictions use similar codes, most have local amendments to these codes that should be referenced. Different cities or towns within the same state may have different code requirements; in addition federal agencies and transportation agencies often have their own code requirements in addition to the local requirements.

*Step 3 – Obtain Information:*

Once the relevant code is obtained, the information should be obtained from within the code should be looked up by an engineer who is familiar with the structure of prescriptive codes. Care should be taken that all of the applicable sections within a single code are reviewed for the item in question.

*Step 4 – Document Code Source and Relevant Sections:*



ATF-LS-FRL Codes and Standards	ID: 1552 Revision: 5
Authority: Technical Leader	Page: 3 of 3
Original maintained by Quality Programs; copies are uncontrolled.	

Documentation will be provided that identifies the name of the code, the year of the code and any local amendments that have been reviewed. In addition, any piece of code that is referenced should also have its Section Number indicated to facilitate review of the code analysis.

*Step 5 – Document Assumptions or Interpretations:*

If there are relevant areas where the prescriptive code requirements are unclear or give several options, the assumptions and interpretations will be documented. Published handbooks or interpretations should be referenced for these areas if available from the publisher of the code.

**6. Documentation:**

Documentation of code analysis will be in accordance with the FRL procedure for Technical Research. The documentation will provide sufficient information that another engineer with a similar level of training can easily find the applicable code sections and arrive at the same conclusion.

**6.1** The documentation shall include a reference to the applicable version of the code used, to include any local amendments or jurisdictional modifications, and the specific code sections(s).

**6.2** The documentation shall include a synopsis of the rationale used in making a decision of compliance/non-compliance. This should include the pertinent details of the building/system/product/etc. as well as any assumptions or interpretations made to arrive at the conclusion.



ATF-LS-FRL Combustion Calorimeter - Standard Operating Procedures	ID: 1571 Revision: 5
Authority: Technical Leader	Page: 1 of 10
Original maintained by Quality Programs; copies are uncontrolled.	

## 1 Scope

This document covers the Standard Operating Procedures for the CWD 2000 Combustion Calorimeter from Union Instruments. The Combustion Calorimeter is used to measure the heat content and specific gravity of natural gas that is used in the Bureau of Alcohol, Tobacco, Firearms and Explosives (ATF) Fire Research Laboratory (FRL) experiments.

## 2 Required Materials

- a) Ultra High Purity (UHP) Methane calibration gas.

## 3 Initial Setup

- a) The combustion calorimeter is located on the south side of the mezzanine level in the Combustion Calorimeter Shed. It is mounted on the east wall of the shed as shown in Figure 1.



**Figure 1. Combustion Calorimeter.**

- b) Connect the combustion calorimeter to the natural gas supply.
- c) Connect the combustion calorimeter to Ultra High Purity (UHP) Methane calibration gas.



ATF-LS-FRL Combustion Calorimeter - Standard Operating Procedures	ID: 1571 Revision: 5
Authority: Technical Leader	Page: 2 of 10
Original maintained by Quality Programs; copies are uncontrolled.	

#### 4 Start-Up

- a) Turn the red valve to the “ON” position where the gas sampling line meets the building main supply (Figure 2).



**Figure 2. Combustion Calorimeter Connection to the Natural Gas Supply Line; Red Valve Shown in the “ON” Position.**

- b) Turn the power switch on the combustion calorimeter to the “ON” position as shown in Figure 3. The power switch is located in the lower right hand corner of the unit.

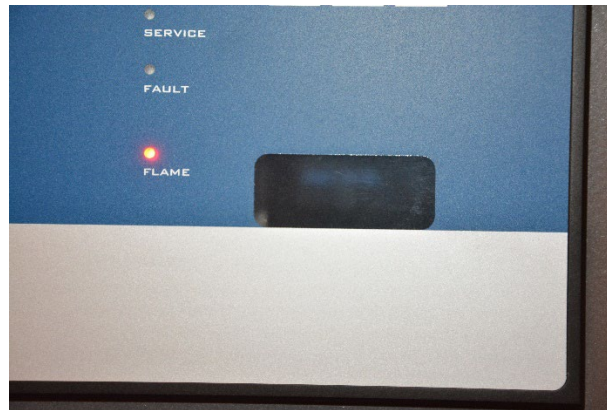

**Figure 3. Combustion Calorimeter Power Switch, Shown in “ON” Position.**



ATF-LS-FRL Combustion Calorimeter - Standard Operating Procedures	ID: 1571 Revision: 5
Authority: Technical Leader	Page: 3 of 10
Original maintained by Quality Programs; copies are uncontrolled.	

- c) If proper gas flow is being provided to the combustion calorimeter, activating the power switch should fire a spark that lights the pilot flame.
- i) When the pilot is lit, the red “Flame” light should be active (Figure 4).



**Figure 4. Pilot Flame Indicator Light and View Port.**

- ii) The pilot flame can be viewed through the viewport next to the “Flame” light. The pilot should be approximately  $\frac{1}{4}$ ” high.
- (1) If the flame is not present or too short, it may indicate a lack of sample line pressure or a problem with the ignition system.
- (2) If the pilot is too high, it may indicate too much pressure in the sample line.
- d) After the pilot is ignited, check the pressure gauges on the right side of the panel (Figure 5). All of the gauges should read between 3.5 and 4.5 mbar. The top gauge shows differential pressure across the specific gravity cell, the middle gauge shows differential air pressure, and the bottom gauge shows gas pressure at the Wobbe jet.



ATF-LS-FRL Combustion Calorimeter - Standard Operating Procedures	ID: 1571 Revision: 5
Authority: Technical Leader	Page: 4 of 10
Original maintained by Quality Programs; copies are uncontrolled.	



**Figure 5. Combustion Calorimeter Pressure Gauges.**

- i) If the pressure is low for the top or bottom gauges, adjust the regulators for the sample or calibration gasses, as shown in Figure 6.
- ii) Use very small adjustments to avoid adding too much pressure.

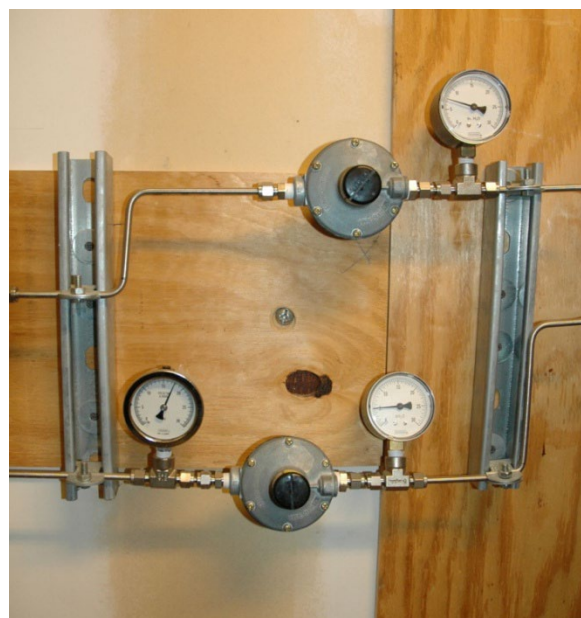

**Figure 6. Combustion Calorimeter Sample Gas (bottom) and Calibration Gas (top) Pressure Regulators.**



ATF-LS-FRL Combustion Calorimeter - Standard Operating Procedures	ID: 1571 Revision: 5
Authority: Technical Leader	Page: 5 of 10
Original maintained by Quality Programs; copies are uncontrolled.	

- e) Check the UHP methane tank to ensure that the valves are open and that there is sufficient gas in the tank to perform calibrations.
- f) Verify that the data cables are correctly plugged into the Data Acquisition System (DAQ). The dry (superior) specific heat ( $CV_s$ ), the saturated (inferior) specific heat ( $CV_i$ ) and the specific gravity (SG) are currently recorded by the Historian via Allen Bradley PLC Modules under the channels “AB183\_AI04\_08”, “AB183\_AI04\_10” and “AB183\_AI04\_09”, respectively.

**NOTE: The combustion calorimeter is left in the “ON” position at all times in order to provide a continuous measurement of the natural gas entering the building. Only turn the combustion calorimeter “OFF” when performing maintenance.**

## 5 During Use

- a) The specific gravity cell within the combustion calorimeter is highly sensitive to vibrations. When entering and leaving the Combustion Calorimeter Shed the door should be opened and closed gently. When opening and closing the combustion calorimeter front panel care should be taken to move the panel slowly and minimize vibration and air flows reaching the specific gravity panel.
- b) The combustion calorimeter’s signal stability is indicated by the “Stab.” label in the upper right corner of the main display screen. When the value is  $> 0.15$  the unit will not provide accurate readings or complete a calibration.
- c) The combustion calorimeter should be maintained in an environment in which the temperature does not vary by more than  $\pm 7$  °C from the temperature at which calibration was performed. It should not be subjected to temperature gradients exceeding 2 °C / hour. If using the combustion calorimeter with a calibration burner, the warning light on the burner control iFix screen will alert that the temperature variation is outside of tolerance.

## 6 Shut-Down

- a) Turn off the power switch located on the bottom right hand corner of the unit.
- b) Close the red valve on the natural gas sampling line.
- c) Close the UHP Methane calibration gas tank.



ATF-LS-FRL Combustion Calorimeter - Standard Operating Procedures	ID: 1571 Revision: 5
Authority: Technical Leader	Page: 6 of 10
Original maintained by Quality Programs; copies are uncontrolled.	

## 7 Calibration

- a) The combustion calorimeter is calibrated with UHP Methane.
- b) The combustion calorimeter automatically performs calibration Monday-Friday at 07:00.
- c) Additional calibration can be initiated at any time using the combustion calorimeter on-screen menu.
  - Options
    - ↳ Calibration
      - ↳ Calibrate
- d) Calibration takes approximately 10 minutes. During this time, the “Operation” light will stop blinking green. The “Operation” light will begin blinking again once the calibration has finished.
- e) Calibration records are recorded and stored within the calorimeter.
- f) Calibration constants specific to the individual calibration gas are entered into the combustion calorimeter. These constants are calculated using a software program from the manufacturer.
- i) The values calculated for UHP Methane (assuming 100% methane and negligible traces of other gasses) are shown in Table 1. The values highlighted in Table 1 are the values that need to be entered into the Combustion Calorimeter “Configuration of Calibration Gases” Page. Figure 7 shows a screen shot of the values entered into the Combustion Calorimeter.



ATF-LS-FRL Combustion Calorimeter - Standard Operating Procedures	ID: 1571 Revision: 5
Authority: Technical Leader	Page: 7 of 10
Original maintained by Quality Programs; copies are uncontrolled.	

**Table 1. Calibration Constants for UHP Methane.**

<b>COMPRESSIBILITY (Z)</b>	0.9981		
<b>SPECIFIC GRAVITY (S.G.)</b>	0.5547		
<b>CALORIFIC VALUE</b>	<b>BTU/SCF</b>	<b>KCAL/NM<sup>3</sup></b>	<b>KJ/NM<sup>3</sup></b>
Net, Dry	913.2	8570	35865
Gross, Dry	1014.3	9519	39834
Net, Saturated	897.3	8421	35241
Gross, Saturated	996.6	9353	39141
<b>WOBBE INDEX</b>			
Net, Dry	1226.1	11507	48154
Gross, Dry (W.I.s)	1361.8	12780	53483
Net, Saturated	1204.8	11307	47317
Gross, Saturated (W.I.)	1338.1	12558	52554
<b>OFFSET FROM CV NET TO VE GROSS</b>	1.1107		

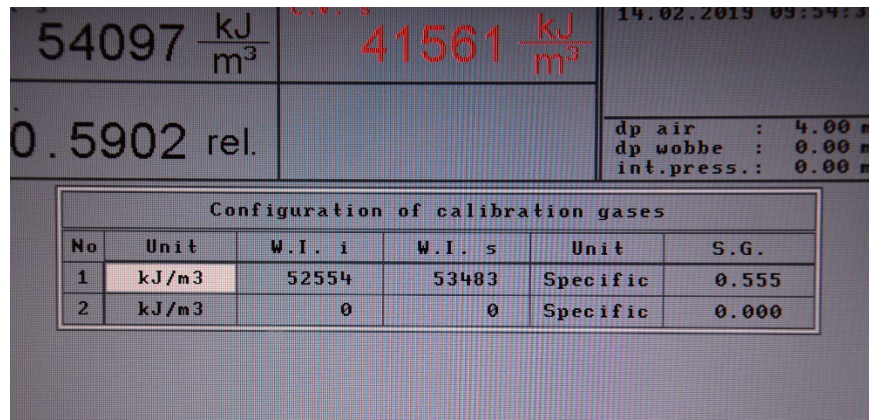

**Figure 7. Combustion Calorimeter Calibration Constant Screenshot.**

- ii) If a calibration gas other than UHP Methane is used the calibration values will need to be recalculated. In this case, contact Delta Instruments to have one of their representatives perform the calculations.



ATF-LS-FRL Combustion Calorimeter - Standard Operating Procedures	ID: 1571 Revision: 5
Authority: Technical Leader	Page: 8 of 10
Original maintained by Quality Programs; copies are uncontrolled.	

## 8 Maintenance

- a) Turn off the combustion calorimeter and close ALL gas lines before performing any maintenance. This system involves natural gas under pressure and should only be operated by those with proper training.
- b) Periodic maintenance checks should be performed to identify any potential problems with the equipment. Delta Instruments recommends that these checks be performed every six months.
  - i) All hose connections to the gauges, pressure sensors, specific gravity cell and the primary air connection to the burner should be checked and changed if necessary.
  - ii) The gas pressure regulator diaphragm should be checked; if this has become hardened or brittle, it should be replaced.
  - iii) The rubber connections on the Wobbe jets and air jets should be checked for any leakage.
  - iv) The calibration gas should be checked to ensure an adequate supply and for expiration date of the gas calibration certification. The combustion calorimeter requires 5-10 liters of calibration gas per calibration cycle, which occurs five times per week.
- c) If any problems are noted when performing maintenance, the following troubleshooting steps can be taken.
  - i) Specific gravity or gas pressure cannot be adjusted to within 3.5 – 4.5 mbar:
    - If the gas or specific gravity cell pressures are outside the 3.5-4.5 mbar range and slight changes to the external pressure regulators (see Startup procedure) do not solve the problem, an engineer may adjust the weight on the internal gas sample regulator.
    - To adjust the gas sample regulator, unscrew the silver metal cap (Figure 8) and add/remove weights as necessary to achieve the required pressure. Note that this will adjust both the specific gravity and gas sample pressures, and it is best to avoid changes to this regulator if possible

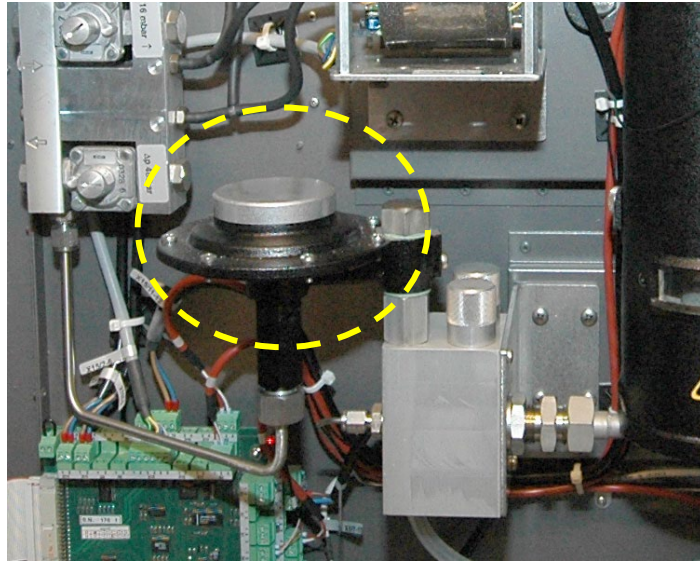

**Figure 8. Combustion Calorimeter Internal Gas Sample Regulator.**

- ii) Air flow pressure reading is less than 3.5 mbar
  - Either the air filter needs to be cleaned/replaced, or the fan unit needs to be replaced.
- iii) Unstable readings
  - Unstable readings may result from rapid temperature fluctuations. If this becomes a problem it may be necessary to provide a more stable temperature control system in the Combustion Calorimeter Shed.
- iv) Drift in readings
  - If readings drift upwards in one direction and are not corrected by calibration the air filter must be replaced.
  - If readings drift downwards it is likely that the heat exchanger is worn out. Remove and wash the heat exchanger with warm water and remove any deposits with a brush. The heat exchanger should be dried with compressed air before reinstallation.
- v) Incomplete/no ignition
  - The pilot flame will not ignite if the door to the unit is open. Close and lock the door in place before attempting to turn on the combustion calorimeter.



ATF-LS-FRL Combustion Calorimeter - Standard Operating Procedures	ID: 1571 Revision: 5
Authority: Technical Leader	Page: 10 of 10
Original maintained by Quality Programs; copies are uncontrolled.	

- It is possible that the ignition electrode is corroded and needs to be replaced.
- Insufficient gas pressure can lead to lack of ignition. Check that the gas line is intact, all valves are open, and pressure regulators are set correctly.

vi) Fault Light

- If the Fault Light comes on, the system will need to be rebooted. The issues is most likely due to a power outage and the unit did not reboot properly.

vii) Product Manual

- The display panel for the CWD 2000 was replaced in September of 2018 with a modern day panel. The replacement display panel is nominally the same as the original panel but the menus are different. When referring to the product manual, refer to the product manual for CWD 2005 for the display panel and refer to the product manual for the CWD 2000 for all other components.

viii) Software problems

- The combustion calorimeter is currently running version 4.42 of the required software. Updates can be made using factory software installed via a floppy drive on the inside of the door of the combustion calorimeter (underneath the monitor).
- All other software problems should be directed to Delta Instruments.



ATF-LS-FRL Commissioning Documentation Requirements	ID: 1596 Revision: 3
Authority: Technical Leader	Page: 1 of 4
Original maintained by Quality Programs; copies are uncontrolled.	

## Scope

This document lists the commissioning documentation requirements for commissioning an instrument or piece of equipment that will be used for casework testing by the Bureau of Alcohol, Tobacco, Firearms and Explosives (ATF), Fire Research Laboratory (FRL). A list of instrument and equipment used by the ATF FRL and the documents required to commission those instruments and equipment shall be maintained by the FRL Laboratory Section Chief (LSC). The terms instrument and equipment will be used interchangeably throughout this document.

## Laboratory Instructions

The Laboratory Instruction (LI) is a document which provides the reader with a general understanding of the instrument. The LI is not intended to serve as a user's manual. The LI at a minimum shall provide the following information;

- A general description of the instrument which describes the type of measurement the instrument records and the scientific principles that it uses to make those measurements.
- The uncertainty and/or accuracy associated with the instrument type.
- The general operating requirements and procedures.
- The information that is required to be documented while using the instrument.

This document is required to be uploaded to Qualtrax. The document file name shall be structured as follows;

FRL LIXXX – Instrument Name.doc

where XXX represents the Laboratory Instruction Number assigned to that instrument and Instrument Name shall be replaced with the actual Instrument Name.

## Technical References

A Technical Reference (TR) should be written to act as supplemental document to the LI when two or more instruments of different types are used to record the same type of measurement. A TR is required for each type of instrument recording the same measurement. The TR should give a physical description of the instrument, state the instruments operating principal, measurement range, measurement output and accuracy.

This document is required to be uploaded to Qualtrax. The document file name shall be structured as follows;

FRL TRXXXy - Instrument Name.doc



ATF-LS-FRL Commissioning Documentation Requirements	ID: 1596 Revision: 3
Authority: Technical Leader	Page: 2 of 4
Original maintained by Quality Programs; copies are uncontrolled.	

where XXX represents the LI Number that the TR was written to supplement and y is a sub letter which starts with a, then b, then c, etc. For example, two TRs are written for LI001, then the two TR document file names would be FRL TR001a – Instrument Name.doc and FRL TR001b – Instrument Name.doc, respectively. The Instrument Name shall be replaced with the actual Instrument Name.

## Standard Operating Procedures

A Standard Operating Procedures (SOP) document shall be written to serve as the Fire Research Laboratory (FRL) user’s manual for the instrument. Upon reading the SOP the user should have a good working knowledge of how the instrument is to be used during a FRL experiment. The following information shall be included in the SOP if deemed necessary during the commissioning process.

- **Required Supplies** – The SOP shall list all supplies required to use the instrument.
- **Start UP Procedures** – The SOP shall list all the necessary procedures required to use the instrument prior to the start experiment.
- **Experiment Procedures** – The SOP shall list all of the necessary procedures required to use the instrument during the experiment.
- **Shut Down Procedures** – The SOP shall list all of the necessary procedures required to use the instrument after the experiment.
- **Maintenance Procedures** – The SOP shall list all of the maintenance procedures require to use the instrument. The procedures can be both preventative and repair procedures if necessary.
- **Calibration or Functional Verification Procedures** – The SOP shall list all calibration requirements or functional verification procedures required to use the instrument.

This document is required to be uploaded to Qualtrax. The document file name shall be structured as follows;

Instrument Name – Standard Operating Procedures.doc

where Instrument Name shall be replaced with the actual instrument name.

## Instrumentation Work Order

The Instrumentation Work Order is a document that is used during the planning stages of a test series to specify the types and quantities of the different instruments that will be required for a particular test series. This document contains a section for each commissioned instrument. When a new instrument is commissioned, a section shall be added to this document which will allow a user to specify the type, quantity and any



ATF-LS-FRL Commissioning Documentation Requirements	ID: 1596 Revision: 3
Authority: Technical Leader	Page: 3 of 4
Original maintained by Quality Programs; copies are uncontrolled.	

specialized information particular to that instrument. The Instrumentation Work Order does not need to be uploaded to Qualtrax.

## Data Sheet

A Data Sheet is a document which is used to record specific data and/or parameters about a particular instrument. All recorded instrument data and/or parameters are maintained using the FireTOSS secured data base and a hard copy is not required. The Data Sheet does not need to be uploaded to Qualtrax.

## FireTOSS Report Template

A FireTOSS report template shall be written if an instrument description is required to be inserted into the experiment report generated by the FireTOSS Print Reports Program. The report template at a minimum shall give a description of the instrument, list the limits or operating range of the instrument, the accuracy and/or uncertainty of the instrument and if necessary, the signal output of the instrument measured by the data acquisition system. The FireTOSS Report Template does not need to be uploaded to Qualtrax.

## List of Standards

If an instrument is constructed to conform to one or more listed standard such as an International Standard Organization (ISO) standard or an American Society for Testing and Materials (ASTM) standard, then a list of those standards shall be included within the LI or TR, whichever is more appropriate.

## Manufacturers Documentation

If an instrument has documentation such as a user manual that comes from the manufacturer when purchased, then a copy of that documentation shall be maintained by the FRL Calibration Technician.

## Training

A training presentation shall be assembled which can be used to teach FRL staff how to use the instrument in accordance with FRL policy. The training presentation shall contain at a minimum the following information;

- A list of materials required to complete the training exercise.
- A description of the instrument and the instrument's operating principle.
- List the factors which could affect the results of the instrument.
- List the calibration and/or functional verification requirements.
- Explain how and where the calibration records are maintained.
- List the FireTOSS parameters associated with the instrument.
- If necessary, list the calculations performed using the data collected by the instrument.
- If necessary, provided an example of the instrument's Test Record.



ATF-LS-FRL Commissioning Documentation Requirements	ID: 1596 Revision: 3
Authority: Technical Leader	Page: 4 of 4
Original maintained by Quality Programs; copies are uncontrolled.	

- If necessary, show an example of the instrument’s Work Order.
- Provided a list of the Manufacturers documentation that would be helpful to read or use as a reference or troubleshooting guide.
- If necessary, provide Hands on Training
- List the “Best Practices” or methods when using the instrument.

The Training Presentation does not need to be uploaded to Qualtrax.

### List of Examiners

A list of Examiners shall be maintained by the LSC. An Examiner understands the scientific principles which the instrument uses to make measurements and has the hands-on technical skills to install and operate the instrument in accordance with FRL procedures. The Examiner can determine if the instrument failed and whether that failure has an impact on the results of the experiment and to determine if that instrument must be taken out of service until it can be verified that the instrument operating properly.

### List of Operators

A list of Operators shall be maintained by the LSC. An operator has the general knowledge of the instrument’s operating scientific principles and has the hands-on technical skills to install and operate the instrument in accordance with FRL procedures. The Operator can determine if the instrument failed but must consult with an Examiner to determine if the failure has an impact on the results of the experiment and whether the instrument must be taken out of service.



ATF-LS-FRL Computer Modeling	ID: 1553 Revision: 4
Authority: Technical Leader	Page: 1 of 3
Original maintained by Quality Programs; copies are uncontrolled.	

**1. Title:** Procedure for use of Computer Modeling

**2. Scope:**

**2.1** This document provides the approach for the use of computer models. This procedure applies to all types of deterministic computer models used by the FRL, including but not limited to zone models, field models and egress models.

**2.2** This procedure is not meant to restrict the methods of analysis available to the engineers, nor does it forbid the use of any specific models.

**3. Description:**

**3.1** Activities covered by this document include any computer-aided calculations used to model the effects of fire or to simulate emergency evacuation scenarios.

**3.2** Computer models can be used to assist with a wide variety of problems. For a given problem there may be one or more models that can provide an appropriate solution, as well as models that are not appropriate for the given scenario. The engineer must be familiar with the assumptions and limitations inherent in the chosen computer model, as well as with the uncertainty involved in the boundary conditions and other variables that are applied by the model-user.

**3.3** When applicable, the default procedure for the use of deterministic fire models is to follow the guidelines provided in ASTM E 1355 “Standard Guide for Evaluating the Predictive Capability of Deterministic Fire Models”. The recommended procedure for the use of computer egress models is to follow the recommendations contained within Appendix A of NIST GCR 06-886 “Guide for Evaluating the Predictive Capabilities of Computer Egress Models”.

**4. Uncertainty:**

There is a level of uncertainty involved in all computer modeling analyses. The uncertainty associated with a given computer modeling analysis should be quantified by the engineer using the methods detailed in the documents referenced in Section 3.3, or by employing another method of uncertainty analysis that is widely accepted in the field of Fire Protection Engineering.

**5. Procedure:**

**5.1** The procedure for the use of computer modeling is as indicated in the flow chart below.



ATF-LS-FRL Computer Modeling	ID: 1553 Revision: 4
Authority: Technical Leader	Page: 2 of 3
Original maintained by Quality Programs; copies are uncontrolled.	

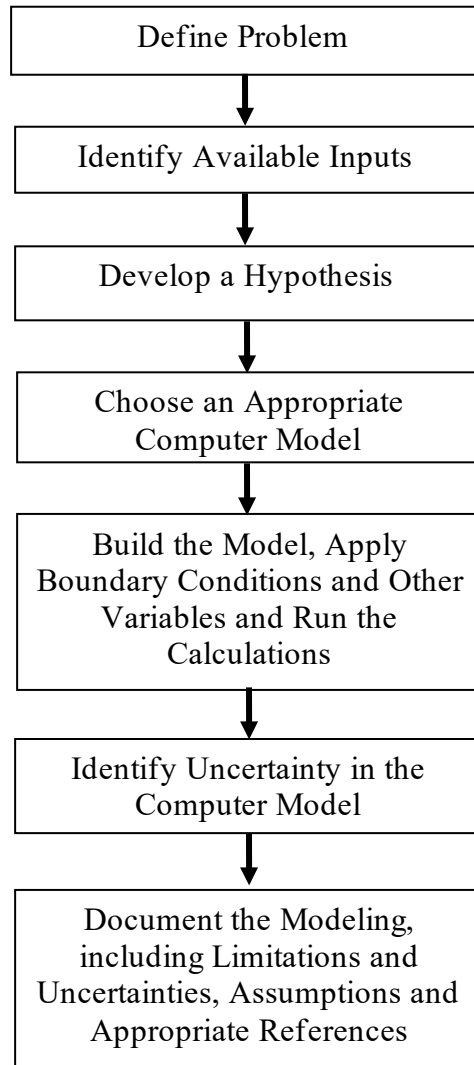

**5.2** The procedural steps for the use of computer models (as illustrated in the flow chart above) are as follows:

*Step 1 - Define the Problem:* Identify the problem by establishing the goals of the fire dynamics calculations and determining the desired output from the analysis.

*Step 2 - Identify Available Inputs:* Gather all of the relevant input variables that are available and determine whether there is enough information to proceed with an analysis. If there is not enough information available for a computer model then an evaluation should be made as to whether laboratory testing will be required to solve the problem.

*Step 3 - Develop a Hypothesis:* Use engineering judgment and other available resources to develop a hypothesis.



ATF-LS-FRL Computer Modeling	ID: 1553 Revision: 4
Authority: Technical Leader	Page: 3 of 3
Original maintained by Quality Programs; copies are uncontrolled.	

*Step 4 - Choose an Appropriate Computer Model:* Choose an appropriate computer model to perform the analysis. An effort should be made to use existing models that have been validated through published literature. If a pre-existing validated computer model is not available, changes to existing models can be made or new computer models can be built to use in the analysis if proper uncertainty analysis and model validation are completed and documented as a part of the analysis.

*Step 5 – Perform the Modeling:* Data files and model inputs should be constructed in a way that can be recorded and reviewed by another engineer. When possible, output files should be used to record the iterative steps performed by the computer model. Technical reviews of both input and output files should be carried out by a competent peer reviewer.

*Step 6 - Identify Uncertainty:* Identify/quantify the uncertainty involved in the calculations in accordance with Section 4 of this document.

*Step 7 – Documentation:* Documentation shall be in accordance with the FRL procedure for “Technical Research” and Section 6 below.

## **6. Documentation:**

Documentation of computer fire modeling analyses will be in accordance with the FRL procedure for Technical Research and will provide sufficient information that another engineer with a similar level of training can review and/or recreate the computer fire modeling work.

Several items specific to computer modeling should be documented:

- The model name and publisher
- The version number of the model
- Any changes or re-compilations that are made to the model during the course of the analysis
- A description of the computer that was used to run the simulations (processor type and speed, operating system, available memory, etc.)



ATF-LS-FRL Cone Calorimeter – Standard Operating Procedures	ID: 6009 Revision: 4
Authority: Technical Leader	Page: 1 of 20
Original maintained by Quality Programs; copies are uncontrolled.	

## 1. Scope

This document contains the Standard Operating Procedure (SOP) for the Fire Testing Technology (FTT) Cone Calorimeter located in the Pyrometrics Laboratory (Pyro Lab) at the ATF Fire Research Laboratory. These procedures were developed based on the FTT SOP [1], which conform to *ASTM E1354* [2], and was modified accordingly for use at the ATF Pyro Lab.

## 2. Required Supplies

### A. Sample

- Conditioned sample
- Sample holder, edge frame and wire grid (if needed)
- Ceramic fiber blanket to be placed in sample holder
- Heavy-duty aluminum foil to wrap sample
- Scale to measure sample mass
- Calipers to measure sample thickness

### B. Reference Bar to Set Cone Height

- 25 mm bar if edge frame not used
- 23 mm bar if edge frame is used

### C. Calibration Gases

- Nitrogen (Zero Grade)
- CO/CO<sub>2</sub> span gas - 0.8% CO, 8% CO<sub>2</sub>, balance N<sub>2</sub> (Primary Standard)
- Methane gas (Chemically pure)

### D. Drying Agent

- Indicating drying agent/desiccant to remove moisture from gas samples

### E. Filter Elements

- Course and fine paper elements for soot filters
- Micro-filter (located in line with the pressure gauges just upstream of the gas analyzers)

### F. Calibrated Weights

- Range applicable to items being tested (approximately 25-50 grams heavier than items being tested)

### G. Smoke Calibration Card

- Black block labeled "Zero"

### H. Water

- Water source required for heat flux gauge



ATF-LS-FRL Cone Calorimeter – Standard Operating Procedures	ID: 6009 Revision: 4
Authority: Technical Leader	Page: 2 of 20
Original maintained by Quality Programs; copies are uncontrolled.	

### 3. Sample Preparation

*Prior to testing, each sample should be conditioned to moisture equilibrium (constant mass) in a conditioning chamber, according to ISO 5660-1 [3]. The ISO standard states that constant mass is achieved when the mass of the sample does not differ by more than 0.1% or 0.1 g, whichever is greater, in two successive measurements in a 24 hour period.*

#### A. Sample Fabrication

- Standard sample size is 100 mm x 100 mm (3.9 inch x 3.9 inch).
- Samples can be up to 50 mm (2 inch) thick. If the sample is nominally thicker than 50 mm, the sample will need to be cut from the unexposed surface to achieve a thickness of 50 mm or less.

#### B. Sample Documentation

- Each sample requires a sample conditioning sheet.
- The individual who is recording the mass measurement will date and initial each measurement.
- Sample dimensions (length, width, thickness, exposed surface area) will be documented on the sample conditioning sheet.
- Initial sample mass will be recorded.

#### C. Sample Conditioning

- Fabricated samples will be placed in a conditioning chamber capable of controlling the temperature and humidity within an enclosed environment.
- The conditioning chamber should typically be set to a temperature of 23°C (73°F) and a relative humidity of 50%.
- Sample mass will be recorded until constant mass is achieved, which occurs when the mass of the sample does not differ by more than 0.1% or 0.1 g, whichever is greater, in two successive measurements in a 24 hour period. [3]

### 4. Start Up Procedures

#### A. Verify Instruments are Calibrated

- At the start of each test day, document the FRL ID numbers for the following instruments and verify that each instrument is calibrated.
  - Data Logger
  - Gas Analyzer
  - Load Cell
  - Methane Mass Flow Meter
  - Heat Flux Gauge



ATF-LS-FRL Cone Calorimeter – Standard Operating Procedures	ID: 6009 Revision: 4
Authority: Technical Leader	Page: 3 of 20
Original maintained by Quality Programs; copies are uncontrolled.	

- Differential Pressure Transducer
- Atmospheric Pressure Transducer (if installed)

## B. Pre-Test Initialization Procedure

- Turn on Instruments
  - a. Turn on the power to the data logger.
  - b. Verify that the gas analyzer is on (*Analyzer* button).

*Note: The gas analyzers take several hours to warm up. Therefore, it should be left on permanently.*
  - c. Verify that the laser is on (*Smoke* button).

*Note: The laser takes several hours to warm up. Therefore, it should be left on permanently.*
  - d. Turn on the main power to the cone calorimeter (*Power* button).
- Cold Trap
  - a. The cold trap valve must be closed during testing and opened after testing is completed to drain away any water that has accumulated (to prevent corrosion).
    - If cold trap valve is closed at the start of a test day, open the valve at the bottom of the cold trap and allow any water to drain. Close valve when finished.
    - If the cold trap valve is open at the start of the test day, close the valve prior to testing.
  - b. Turn on the power to cold trap (*Cold Trap* button). Allow cold trap to run for approximately 15 minutes prior to turning on sample pump.
  - c. Ensure that the cold trap temperature has reached 0°C (32°F) prior to testing. The temperature can be checked any time in the *Status* section of the *ConeCalc* software.
- ConeCalc Software
  - a. Start the *ConeCalc* software program on computer.
- Check Filters and Drying Agents
  - a. Check that the indicating drying agent/desiccant is in good condition. Change if necessary.
  - b. Check that the primary (course) filter and secondary (fine) filter are clean. Change if necessary.

## C. Pre-Test Calibration Procedures

- Zero Methane Mass Flow Meter
  - a. Ensure that the *Methane On/Off* valve on the cone calorimeter is set to **OFF**.



ATF-LS-FRL Cone Calorimeter – Standard Operating Procedures	ID: 6009 Revision: 4
Authority: Technical Leader	Page: 4 of 20
Original maintained by Quality Programs; copies are uncontrolled.	

- b. Using the *ConeCalc* software, select *Calibrations/Zero MFMs* and press the **Zero** button to zero the methane flow meter in the *ConeCalc* software.
- c. Check that the display for voltage (V), flow (slpm), and heat output (kW) all read 0.00.
- d. Then press **OK**.
- Set Exhaust Duct Flow
  - a. Verify that the *Exhaust Control On/Off switch* is set to **OFF** and the *speed controller* is set to 0%.
  - b. Turn the *Differential Pressure Transducer (DPT) valve* to the **OFF** position.
  - c. In the *ConeCalc* software, select *Calibrations/DPT & Flow*.
  - d. Press the **Zero** button. After several seconds of collecting data, the pressure should read approximately 0.00 Pa.
  - e. Press **OK** to record the zero point of the DPT calibration.
  - f. You will then be promoted to set the exhaust flow. Enter in the required flow rate of **24 l/sec**.
  - g. Turn the *DPT valve* to the **ON** position.
  - h. Turn the *Exhaust Control switch* to the **ON** position.
  - i. Slowly adjust the fan speed controller from zero to the required volume flow rate of 24 l/s, which is approximately **47%** on the exhaust speed controller.
  - j. Click **OK** on the computer. The measured flow rate will then be displayed on the screen.
  - k. When 15 consecutive readings have been measured that are within 2 l/s of the required flow, the software will tell you that the flow is correctly set. **Do not adjust the fan speed once the flow has been set.**
  - l. Press **OK** to return to the calibrations panel in the software.

#### D. Calibrate Gas Analyzers

1. In *ConeCalc* software, select the software routine *Calibrations/Gas Analyzers*.
2. Open the cylinders for the zero gas (nitrogen) and the span gas (CO/CO<sub>2</sub>), which are located in the gas cylinder closet (Closet A) across from the Pyro Lab. Also, open the cylinder for the methane gas, which is located in the adjacent closet (Closet B).
3. In the Pyro Lab, there is a gas manifold located above the front of the cone calorimeter. Open the valve tagged “N<sub>2</sub>”.
4. On the cone calorimeter, switch both gas analyzer valves to the *Nitrogen* position.
5. Adjust the gas pressure to 5 psi for each gas analyzer. **THIS IS VERY IMPORTANT.** There are three ways to adjust the gas pressure, of which the first one is the preferred



ATF-LS-FRL Cone Calorimeter – Standard Operating Procedures	ID: 6009 Revision: 4
Authority: Technical Leader	Page: 5 of 20
Original maintained by Quality Programs; copies are uncontrolled.	

method:

- a. Adjust the valve labeled “nitrogen”, which is located below the load cell area of the cone calorimeter.
  - b. Adjust the gas regulator positioned near the pressure gauges upstream of the gas analyzers (only use this method to make minor changes to the pressure).
  - c. Adjust the nitrogen tank output pressure using the tank regulator.
6. Wait at least 5 minutes until the O<sub>2</sub>, CO, and CO<sub>2</sub> readings stabilize at approximately 0.0%.
  7. Zero the CO on the gas analyzer, using the menu system (Menu|Calibrate|██████████|Manual Cal|▲|▲CO|Low Cal|0.0000%|Yes). When the CO reading has stabilized at 0.000%, press **Quit** twice.
  8. Then press ▼ to select the CO<sub>2</sub> channel. Select **Low Cal** and ensure the display says 0.000% and select **Yes** to perform the calibration. Then press **Quit** twice.
  9. Then press ▼ to select the Oxygen channel. Select **Low Cal** and ensure the display says 0.000% and select **Yes** to perform the calibration. Then press **Measure** to exit the calibration screens on the gas analyzer.
  10. In the *Gas Analyzers Transducer Calibration* panel press the **Zero** button in the Oxygen Cell section. After the routine has finished (the progress bar has reached the top) check that the Oxygen reads 0.000% on the computer screen.
  11. Then press the **Zero** buttons in the CO<sub>2</sub> cell and CO cell sections. Check that the CO<sub>2</sub> and CO both read 0.000% on the computer screen. DO NOT press the OK button.
  12. Close the valve tagged “N<sub>2</sub>” on the gas manifold above the cone calorimeter.
  13. On the cone calorimeter, turn the valve for the O<sub>2</sub> analyzer to *Sample Gas*. DO NOT turn on the sample pump at this time.
  14. Open the valve tagged “CO” on the gas manifold above the cone calorimeter.
  15. On the cone calorimeter, turn the valve for the CO/CO<sub>2</sub> analyzer to *CO/CO<sub>2</sub> Span Gas*.
  14. Set the CO/CO<sub>2</sub> pressure entering the gas analyzer to 5 psi and wait approximately 5 minutes for the CO/CO<sub>2</sub> readings to stabilize. Note that the gas pressure can be adjusted following the steps outlined in Step 5, except that the gas is CO/CO<sub>2</sub> instead of N<sub>2</sub>.
  15. On the analyzer menu system select Menu|Calibrate|██████████|Manual Cal|▲|▲CO|High Cal| then ensure that the value is that stated on the calibration gas bottle certificate. Then select **Yes** to perform the calibration of the CO cell.
  16. When the reading has stabilized press **Quit** twice.
  17. Then press ▼ to select the CO<sub>2</sub> channel. Select High Cal and ensure the display shows the value is that stated on the calibration gas bottle certificate and select **Yes** to perform the calibration of the CO<sub>2</sub> cell. Then press **Measure**.



ATF-LS-FRL Cone Calorimeter – Standard Operating Procedures	ID: 6009 Revision: 4
Authority: Technical Leader	Page: 6 of 20
Original maintained by Quality Programs; copies are uncontrolled.	

18. Check that the CO and CO<sub>2</sub> Span Values on the computer screen match those on the calibration gas bottle certificate (if not then edit the values). Then press the **Span** buttons for the CO<sub>2</sub> and CO cells. Check that the CO and CO<sub>2</sub> values are adjusted to the correct span concentrations.
19. Close the valve tagged “CO” on the gas manifold above the cone calorimeter.
20. Turn the valve for the CO/CO<sub>2</sub> analyzer to *Sample Gas*.
21. Turn on the sample pump (*Pump* button).
22. Let the oxygen concentration stabilize for at least 5 minutes.
23. On the analyzer menu system select Menu|Calibrate [REDACTED]|Manual Cal|Oxygen|High Cal| then ensure that the value is 20.95%. Then select **Yes** to perform the calibration. When the reading has stabilized press **Measure**.
24. Press the **Span** button in the Oxygen section on the computer screen. Check that the Oxygen value on the computer screen is 20.95%.
25. Leave the sample pump on.
26. Then press the **OK** button to accept all the gas analyzer calibrations in ConeCalc.
27. Press **Main** to return to the Main panel in ConeCalc.

#### E. Perform the C-Factor Calibration

1. Ensure that the sample pump is on and has been running for at least 15 minutes.
2. Open the valve tagged “CH<sub>4</sub>” on the gas manifold above the cone calorimeter.
3. Place the calibration burner in position under the cone.
4. Ensure the spark igniter is in the idle position and push the *Ignition button ON*.
5. Select **C-factor** from the Main panel in the *ConeCalc* software. The C-factor panel will open and then select **Routine**.
6. Enter the required information for the C-factor test.
  - a) Change the *filename* by selecting the **File** button and then select the folder to store the C-factor file.
    - i) In general, the C-factor file is stored in the directory of the sample for the first test of that day.
    - ii) Use the following filename configuration for a C-factor test: “*CFactor\_mmdyy.csv*”, where “mm” is the two digit month, “dd” is the two digit day”, and “yy” is the last two digits of the year.
  - b) The information for the *Apparatus Specifications* does not need to be changed.
  - c) Enter in the current temperature, relative humidity, and pressure for the *Atmospheric Conditions*.
  - d) Verify the *Carbon dioxide* is set to **Non-scrubbed**.



ATF-LS-FRL Cone Calorimeter – Standard Operating Procedures	ID: 6009 Revision: 4
Authority: Technical Leader	Page: 7 of 20
Original maintained by Quality Programs; copies are uncontrolled.	

- e) Verify that the HRR Level for the *Burner* is set to **5 kW**.
7. Press **OK** after all the relevant information has been entered.
  8. Verify that the gas analyzers display the following values:
    - a) O<sub>2</sub>: 20.95 % ± 0.01 %
    - b) CO<sub>2</sub>: 0.040 % ± 0.005 %
    - c) CO: 0.000 % ± 0.003 %
- If any of the gas analyzers are outside of their tolerances, then either a High Cal must be performed for the O<sub>2</sub> analyzer or Low Cal for the CO/CO<sub>2</sub> analyzer.
9. After verifying the readings on the gas analyzers are within tolerance, open the shutters under the Cone heater.
  10. Ensure that the *Methane valve* on the cone calorimeter is in the **OFF** position.
  11. In the *ConeCalc* software, select **Yes** to perform the pre-run calibrations.
  12. Press **Start** in the C-factor Calibration panel to collect the baseline data.

*Note that during the entire C-factor routine, ensure that the sample line pressure for O<sub>2</sub> and CO/CO<sub>2</sub> remain at 5 psi. Adjust the regulators positioned near the pressure gauges upstream of the gas analyzers as necessary.*
  13. Place the igniter over the methane burner and visually verify that it is sparking.
  14. Plug power into the mass flow meter for the methane burner and verify/adjust the setpoint to 9.2 slpm.
  15. When instructed by the computer program, open the *Methane gas valve* on the cone calorimeter
  16. Remove the igniter after the methane gas ignites.
  17. Verify the flame is within the opening of the cone heater. If not, adjust the position of the burner and then secure in place.
  18. If necessary, adjust the methane flow on the mass flow meter to obtain approximately 5 kW. The HRR is shown in the bottom left graph and display using the *ConeCalc* software.
  19. Allow the data collection part of the routine to complete and close the *Methane gas valve* when instructed. (DO NOT adjust the methane flow valve or the pressure regulator on the bottle during the data collection phase (last 3 minutes of the routine).
  20. Press the **Stop** button to finish the routine when instructed.
  21. Press **Save Mean** to save the *Mean C-factor*. Press the **Exit** button to return to the C-factor panel.
  22. Press the **View Log** button to view a log of the saved C-factors. The acceptable range for the instrument is 0.040 - 0.046. Compare the current C-factor to the previous value. The difference between the two C-factors can be calculated automatically by selecting the current and previous C-factors on the C-factor graph.



ATF-LS-FRL Cone Calorimeter – Standard Operating Procedures	ID: 6009 Revision: 4
Authority: Technical Leader	Page: 8 of 20
Original maintained by Quality Programs; copies are uncontrolled.	

*Measurements on two successive test days shall not differ by more than 5%. Such differences indicate malfunctions, which require rectification before testing is continued. Typically, a high C-factor results because of leaks or blockages, a very high C-factor means that the cold trap is still open, a low C-factor may be due to a leak in the methane line or a faulty mass flow meter.*

23. Press the **Close** on the C-factor Log Panel to return to the C-Factor panel. Then Press the **Exit** button to return to the Main panel.
24. Remove power from the mass flow meter.
25. Turn the *Ignition* **OFF** and remove the methane burner.
26. If it will be more than 20 minutes before a test is run, turn off the sample pump.
27. Close the valve tagged “CH<sub>4</sub>” on the gas manifold above the cone calorimeter.
28. Close all of the gas cylinders located in the gas cylinder closets.

#### **F. Calibrate Smoke System (this section only applies if smoke measurements are obtained)**

1. Place the "smoke zero blank" (a black metal block for interrupting signal between laser and photodiode) between the laser and the compensating photodiode (next to the laser).
2. Select the software routine *Calibrations/Smoke* and then press the **Zero** button.
3. Check that the Calibrated Main and Compensating signals [PDM(-) and PDC(-)] are 0.000. If not, then press the **Zero** button again.
4. Remove the smoke zero blank and ensure that the blank slot and filter slot is covered.
5. Press the **Balance** button to adjust the input values of each of the photodiodes to give a normalized ratio of 1.000 (this is in the PDC(-) and PDM(-) displays). The Transmission (%) panel should also read approximately 100%. If not, then press the **Balance** button again.
6. Then press the **OK** button.

#### **G. Configure Load Cell**

1. Turn on power to the load cell (*Load Cell* button).
2. Check that the range of the load cell is appropriate for the mass of the specimens that will be tested.
  - a. From the main menu of the *ConeCalc* software, select *Configuration*.
  - b. Verify that the upper range of the load cell (indicated by the “*measured span*” value) is greater than the mass of the specimens to be tested.

**Note that it is very important that the specimen mass does not exceed the upper range of the load cell as specified in the *ConeCalc* software. Although the load cell controller will display the correct mass, the signal sent to the computer will “top out” (i.e., the signal will be greater than 10 V). Therefore, an incorrect mass reading will be recorded and all parameters involving mass calculations will be invalid.**

- c. Click the **Cancel** button to return back to the *ConeCalc:Main* screen.



ATF-LS-FRL Cone Calorimeter – Standard Operating Procedures	ID: 6009 Revision: 4
Authority: Technical Leader	Page: 9 of 20
Original maintained by Quality Programs; copies are uncontrolled.	

- d. Click the **Status** button to go to the *ConeCalc:Status* screen.
3. If the load cell has already been set to the desired range for a series of tests, then only a 2-point verification is required. **Otherwise, proceed to Step 4 to change the range.**
  - a. Add an empty sample holder (with fiber blanket, edge frame, and grid if used) to the load cell.
  - b. Push the **Tare** button below the load cell controller. Verify that the load cell controller and the mass on the *Status* screen both show a value of **0**.
  - c. Add a weight to the sample holder that is slightly greater than the largest mass to be tested. Verify that the load cell display and the mass on the *Status* screen are both reading the correct weight. **No additional configuration of the load cell is required. Proceed to the *Experimental Procedures* section.**
4. **Perform the following steps, only if a new load cell range is required.** To configure the range of the load cell, both the load cell controller and the load cell settings in the *ConeCalc* software must be adjusted.
  - a. Determine the maximum mass ( $m_{max}$ ) of the samples that will be tested. Choose a range slightly larger than this largest mass. For example, if the samples weigh about 80 g, then select 100 g as a full scale load.
  - b. Use the following procedure to set the new range in the load cell controller.

PUSH	DISPLAY	COMMENTS
MENU x 17	OT.SC.OF	
MIN	READ1	
MAX/MIN	00000.0	READ1 must be 00000.0
MENU	OUTPT1	
MAX/MIN	00.0000	OUTPT1 must be 00.0000
MENU	READ2	
MAX/MIN	<b>MMAX</b>	Enter maximum mass here (e.g., 00100.0)
MENU	OUTPT2	
MAX/MIN	10.0000	OUTPT2 must be 10.0000
MENU	STORED	RESET2

- c. Use the following procedure to set the new range in the *ConeCalc* software.
  - i. From the main menu of the *ConeCalc* software, select *Configuration*.
  - ii. In the *Transducer Calibrations* window, edit the load cell information as shown below, so that the four numbers match those entered into the load cell controller in Step 4b.

	Output		Measured	
	Zero	Span	Zero	Span
Load Cell	0 V	10 V	0 g	$m_{max}$ g



ATF-LS-FRL Cone Calorimeter – Standard Operating Procedures	ID: 6009 Revision: 4
Authority: Technical Leader	Page: 10 of 20
Original maintained by Quality Programs; copies are uncontrolled.	

- iii. After entering the number, press **Accept**.
- iv. Then select **Status** from the main menu.
- v. Add an empty sample holder (with fiber blanket, edge frame, and grid if used) to the load cell.
- vi. Push the **Tare** button below the load cell controller. Verify that the load cell controller and the mass shown in the status window both show a value of **0**.
- vii. Add a weight to the sample holder that is slightly greater than the largest mass to be tested. Verify that the load cell controller and the mass shown in the status window both show the correct value of the weight added.

## 5. Experiment Procedures

### A. Prepare Sample

1. Remove sample from conditioning chamber.
2. Measure and record the sample mass. Verify that the sample has achieved constant mass.

*Constant mass is achieved when the mass of the sample does not differ by more than 0.1% or 0.1 g, whichever is greater, in two successive measurements in a 24 hour period.*

3. Wrap the sample in one layer of heavy-duty aluminum foil, shiny side towards the sample, covering the sides and bottom and leaving the testing surface exposed
4. Place sample in a clean horizontal sample holder, which contains a ceramic fiber blanket.

*The ceramic fiber blanket must be dried by heating to 150°C (300°F) for at least 3 hours and then placed in a desiccator containing a drying agent/desiccant to remove any water.*

5. If needed, use the optional edge frame and/or wire grid. If a different mounting procedure is to be used, as specified by the test sponsor, take the appropriate steps and document properly for records.

### B. Tare Load Cell

1. Remove the sample from the sample holder.
2. Place the empty sample holder (including edge frame and/or wire grid if used) on the load cell.
3. Allow the mass reading to stabilize.
4. Press the **Tare** button on the Mass Loss Calorimeter section of the cone calorimeter.
5. Remove the sample holder from the load cell. **DO NOT PRESS THE TARE BUTTON AGAIN.**



ATF-LS-FRL Cone Calorimeter – Standard Operating Procedures	ID: 6009 Revision: 4
Authority: Technical Leader	Page: 11 of 20
Original maintained by Quality Programs; copies are uncontrolled.	

### C. Check Height of Cone Heater

1. Ensure that the cone heater is at the proper distance above the sample surface.
  - a. Use the 25 mm reference bar if the edge frame is not used. Measure from the top of the sample surface to the bottom of the cone heater.
  - b. Use the 23 mm reference spacer if the edge frame is used. Measure from the top of the edge frame to the bottom of the cone heater.

### D. Set Heat Flux

1. Ensure that the cooling water to the heat flux meter is flowing.
2. Place a non-combustible cover on the load cell platform.
3. Open the shutters under the cone heater.
4. Remove the red cap from the heat flux meter. **NEVER TOUCH THE BLACK SURFACE ON THE HEAT FLUX METER.**
5. Place the heat flux meter under the cone heater and set it to the desired distance below the cone heater. Use the appropriate reference bar (25 mm or 23 mm) to set the height. Take care to NOT touch the black surface of the heat flux gauge.
6. Turn on the power to the cone heater (*Cone* button)
7. Using the ConeCalc software, select *Heat Flux*.
8. Select the required heat flux from the drop down list and then adjust the temperature controller to give the required heat flux. This is done by pressing the ▼ and ▲ buttons on the temperature controller. If the desired heat flux has been tested previously, the temperature controller set point will be displayed on the ConeCalc screen.
9. When the temperature has stabilized, look at the heat flux meter reading (Irradiance) displayed in the program.
10. Adjust the temperature using the ▼ and ▲ buttons until the irradiance is at the required level (the Irradiance display will be green).
11. When the heat flux is stable, press the **Save & Exit** button.
12. Remove the flux meter.
13. Check that the copper end of the heat flux meter is cold.
14. Place the red cap on the flux meter and store the meter under the load cell platform.
15. Turn on the sample pump (this will allow for adequate warmup time prior to testing).
16. Leave the shutters open. Make sure the non-combustible cover is on the load cell platform.



ATF-LS-FRL Cone Calorimeter – Standard Operating Procedures	ID: 6009 Revision: 4
Authority: Technical Leader	Page: 12 of 20
Original maintained by Quality Programs; copies are uncontrolled.	

### E. Setup Video Camera (*Optional*)

*Recording video during a cone calorimeter experiment is not required. If using a video camera to record the experiment, complete the following steps.*

1. Mount the video camera so that it does not obstruct the operator from installing the sample holder on the load cell.
2. Turn the video camera on and adjust the zoom of the lens so that the video camera is focused on the top of the sample. *Typical video camera views include the bottom of the sample holder to the bottom of the hood, which allows the operator to observe relevant testing events.*
3. Ensure that the video camera is routed through the Pyrometrics Lab to a known DVR channel.

### F. Pre-Test Final Check

1. Put the specimen in the sample holder. Secure the edge frame to the sample holder, if used.
2. Check the system one more time, as follows:
  - a. Ensure that there is sufficient drying agent in the column.
  - b. Check that the laser system slots are covered.
  - c. Check that the pressure to the oxygen and CO/CO<sub>2</sub> analyzers is the same as it was during the calibration of the analyzer (5 psi).
  - d. Check that the volume flow rate through the duct is 24 l/s ± 2 l/s.
  - e. Check that the heater temperature is the same as the temperature noted at the time of the heat flux setting.
  - f. Ensure that the sample pump has been running for approximately 15 minutes.
  - g. Check that the O<sub>2</sub> concentration is approximately 20.95% over a 1 minute period. If not, then perform a high calibration of the O<sub>2</sub> analyzer by using Calibrations/Gas Analyzers and then press **High** in the Oxygen Cell section. Note that you may have to also adjust the high calibration point in the analyzer software.
  - h. Ensure the spark electrode is in the idle position and then turn the spark igniter on.
3. Select **Start Test** in ConeCalc and then enter the required information listed below. Remember that your tests are performed "**Non-scrubbed**" and you must enter the correct laboratory conditions (temperature, relative humidity and atmospheric pressure).
  - a. The sponsor for the experiment should be the FireTOSS assigned case number, both for research and casework testing.



ATF-LS-FRL Cone Calorimeter – Standard Operating Procedures	ID: 6009 Revision: 4
Authority: Technical Leader	Page: 13 of 20
Original maintained by Quality Programs; copies are uncontrolled.	

- b. The sample description should be used to provide a general label for the sample type.
  - c. The Sample ID is chosen pre-test by the operator and should be filled into the Material name/ID as well as the Test/report name fill in sections.
  - d. Ensure the test time is set to **1 second** intervals.
  - e. Ensure the operator is selected from the drop-down menu. If a new operator is running the experiment, their name can be added to the list.
  - f. If using the edge frame, ensure that the button is checked, and the sample area is set to 88.4 cm<sup>2</sup>. If the edge frame is not used, ensure the edge frame button is not checked and the sample area is set to 100 cm<sup>2</sup>.
  - g. If the sample is prepared as exemplar in the laboratory and have specific requirements for completion or assembly, note these items in sample preparation fill in form section
  - h. If the sample has specific manufacturer information, note in the manufacturer fill in form section
    - If there are multiple manufacturers or other notes to describe, provide further detail in the notes fill in form section
  - i. Set the file name and desired save location prior to testing.
    - File names do not have a specific requirement, but in general they are typically saved as the sample name in a folder of the same naming convention, created by the test operator.
    - *Note that PMMA tests should be saved with the naming convention PMMA – mmddy\_1,2,3,etc. These experiments should be saved with the sponsor for the next upcoming test series. The description should be set as PMMA and the sample ID as PMMA-mmddy\_1,2,3,etc. These experiments are run without the edge frame.*
  - j. Note that sample information can be loaded from previous projects to save time in filling out specific information. However, the following information will still need to be updated prior to testing: Sample ID, mass, dimensions, test number, heat flux, lab conditions, file save name and location.
    - Information can be loaded from the last experiment, or from a different experiment (Load Other) that will prompt the user to select a file from a file directory window
- Note that changes can be made to the test setup parameters after the experiment is completed. This can be achieved through print reports/edit data/test information.*
4. Then press **OK**.
  5. Then perform the pre-run calibrations by pressing the **Yes** button.



ATF-LS-FRL Cone Calorimeter – Standard Operating Procedures	ID: 6009 Revision: 4
Authority: Technical Leader	Page: 14 of 20
Original maintained by Quality Programs; copies are uncontrolled.	

## G. Testing

1. Open up FireTOSS Experiments. Create a new experiment and enter in all relevant sample and project information. *Note that the Laboratory Conditions Object must be removed.*
2. If recording video during the experiment (*optional*):
  - a. Open iFIX and select the created FireTOSS Experiment ID. *This can be easily achieved if the operator clicks the FireTOSS logo on the Experiment Select tab, which automatically selects the current highlighted experiment in FireTOSS. The selected experiment in iFIX will also show at the top left of the program screen.*
  - b. Open the Video tab. Select the assigned DVR for the camera, which will assign the DVR to the selected Experiment ID.
  - c. Start the test in iFIX (*which will also start recording the video*).
3. Ensure that the shutters are open. DO NOT put the specimen on the load cell at this time.
4. In ConeCalc, press **Start Baseline** and collect at least 60 seconds of data.
5. While the baseline data is being collected, open the time capture program on the desktop, which is named **Timestamp.exe**.
6. When instructed to insert the specimen, close the shutters and remove the non-combustible cover from the load cell.
7. Place the sample holder with the specimen on the load cell and allow the mass to stabilize.
8. If desired, pull down the protection screen on the cone calorimeter.

*Note: if the test is being documented with a video camera and/or photographs, the use of the protection screen is not recommended.*
9. Move the spark igniter into position and ensure that the *Igniter* button is **ON**.
10. To start the test, open the shutters, press the “S” key on the keyboard or hand set, and click the Record Time on the *Timestamp* program.

*Note: It is suggested that two people run each test, due to the multiple tasks that occur simultaneously. For example, one person will open the shutters, while the other person presses the S key and clicks the Record Time on the Timestamp program. **If the operator presses the “S” key after the test has been started in ConeCalc, then the test will stop without any option to continue.***
11. When sustained ignition occurs, record the time by pressing the “I” key on the keyboard or hand set. Remove the spark igniter.

*Note: sustained ignition occurs when a flame exists over most of the test specimen surface for at least 4 seconds. Also, if the “I” key is pressed multiple times, the program will only keep and record the last time the key is pressed.*



ATF-LS-FRL Cone Calorimeter – Standard Operating Procedures	ID: 6009 Revision: 4
Authority: Technical Leader	Page: 15 of 20
Original maintained by Quality Programs; copies are uncontrolled.	

12. Press the “E” key on the keyboard or handset to mark an event time. This time will be displayed in the *Comments* dialogue box after the end of the test, where comments about the event can be entered. *(It is important to hand write the event at the time of occurrence to input into ConeCalc at the end of the test.)*
13. When the specimen stops flaming, press “F” key on the handset or keyboard (this records the flameout time).  
*Note: If the “F” key is pressed multiple times, the program will only keep and record the last time the key is pressed.*
14. Collect data for an additional 2 minutes.
15. Press the “S” key on the handset or keyboard to stop the test or press the “Stop” button in ConeCalc.
16. If the specimen does not ignite within 30 minutes, terminate the test and discard the sample, unless the specimen is showing signs of heat evolution ( $HRRPU > 5 \text{ kW/m}^2$ ) or unless specific alternative instructions have been received from test sponsor. If burning occurs for more than 1 hour, stop test at 1 hour and remove sample.
17. Close the shutters. Remove the specimen and place it under the laboratory fume hood. Place the non-combustible cover on top of the load cell.
18. Open the shutters.
19. Stop the experiment in iFIX *(thus stopping the video)*
20. Turning off the sample pump between experiments can reduce the amount of indicating drying agent/desiccant used during the tests. If the sample pump is shut off between experiments, make sure to turn the sample pump back on at least 10 minutes prior to starting the next experiment.

## H. Post Test Procedure

1. In ConeCalc, click on the *Print Report* menu.
  - a. When the *Print Test Report* opens, verify that the current sample data has been loaded.
  - b. Click *Export Data* to generate a reduced data file.
  - c. Save the file with the default naming convention (the program will add a “\_red” to the end of the original filename).
2. Check the reduced data file to verify the sample time interval and data generated are correct.
3. Open the raw data file and change the value for the “Time of Test” (B6 in Excel) to the time listed in the time capture program (TimeStamper.exe). ***Make sure that the file format is changed to hh:mm:ss.***



ATF-LS-FRL Cone Calorimeter – Standard Operating Procedures	ID: 6009 Revision: 4
Authority: Technical Leader	Page: 16 of 20
Original maintained by Quality Programs; copies are uncontrolled.	

4. Open the Cone Calorimeter Upload Data Program. *This program uploads ConeCalc data into a FireTOSS experiment.*
  - a. Add the Experiment ID from FireTOSS.
  - b. Find the raw data file associated with the Experiment ID and select it (*the reduced data file is associated with the raw file through the naming convention and will be automatically populated in the upload program*).
  - c. Import the data into FireTOSS.
5. Open FireTOSS and verify that the data has been imported correctly.
  - a. Select the *Cone Calorimeter* object.
  - b. Type “Cone” into the *Description* row. The bar codes for the equipment assigned to the Cone Calorimeter will automatically be populated in the “Cone Calorimeter” object. *Note that the FireTOSS computer must be connected to the calibration database for this to occur.*
6. Upload any test photos into FireTOSS.
7. Attach the C-Factor file to the first test conducted that day.

## 6. Shut-Down Procedure

1. Adjust the cone heater temperature to 0°C.
2. Turn the exhaust fan off after cone temperature drops below 250°C.
3. Turn the following buttons OFF:
  - a. Pump
  - b. Cold Trap
  - c. Load Cell
  - d. Ignition
  - e. Cone
4. Turn off data logger.

*Leave the Gas Analyzers and Smoke buttons on all the time.*
5. Shut down the ConeCalc application.
6. Ensure that the gas bottles are turned off.
7. Ensure that the cooling water is turned off.
8. Open the Cold Trap drain valve to drain the water. Leave the tap open until the next time the instrument is used.



ATF-LS-FRL Cone Calorimeter – Standard Operating Procedures	ID: 6009 Revision: 4
Authority: Technical Leader	Page: 17 of 20
Original maintained by Quality Programs; copies are uncontrolled.	

## 7. Maintenance

Periodic maintenance of the cone calorimeter is required. Listed below are items that need to be maintained on a regular basis.

### A. Gas Sampling System:

The components of the gas sampling system listed below should be cleaned at the indicated times. The usual indication of clogging of the gas sampling system is the need to re-adjust the bypass valve repeatedly to maintain the proper flow to the analyzers. If clogging occurs, cleaning of the gas sampling system will need to be performed on a more frequent time interval. *Note that any time a change is made to the gas sampling system (e.g., replacing the sample lines), then the gas analyzer time offsets need to be verified [4].*

1. **Sample Ring** - The sample ring should be cleaned once a year, at a minimum. The necessary frequency of cleaning will depend entirely on how much testing is being done and on the amount of soot produced by the test specimens. The gas sample ring cleaning should coincide with the ductwork cleaning.
2. **Sample Lines** - The gas sample lines should be replaced once a year, at a minimum. If clogging occurs, the lines should be blown out using compressed air, starting from the gas analyzer and working back towards the sampling ring. Never blow compressed air into the gas analyzer. If clogging continues to occur, replace the sample lines. After replacing any sample lines, complete the following leak check procedure:
  - a. Check to make sure that both Sample Gas valves on the cone calorimeter are switched to the "Sample Gas" position.
  - b. Ensure that the desiccant tubes are full.
  - c. Turn on the gas sample pump and check for leaks or blockages.
    - Ensure that the pressure to the gas analyzers is 5 psi on the gauge inside the rack.
    - The flow to the gas analyzers should be 3 - 3.5 lpm on the rotameters.
    - If leaks are present, locate the source of the leaks and correct the problem.
  - d. Turn off sample pump.
3. **Soot Filtration** - The soot filtration system consists of four filters, three of which contain a paper filter element. The first, and largest filter, is used for course filtration and will require frequent replacement and cleaning. The second filter is used for finer filtration and will require replacement at a less frequent rate than the course filter. The course paper element needs to be checked and replaced (as necessary) at the beginning of each test day, prior to the C-factor test, and prior to each test. The second paper element should be checked periodically and replaced if it shows signs of use. The third filter is an enclosed high-efficiency particulate air (HEPA) filter sealed in a plastic casing. This filter is located at the inlet to the sample pump and



ATF-LS-FRL Cone Calorimeter – Standard Operating Procedures	ID: 6009 Revision: 4
Authority: Technical Leader	Page: 18 of 20
Original maintained by Quality Programs; copies are uncontrolled.	

needs to be checked at minimum every six months for soot build up. If the filter is discolored, then it should be replaced. The final filter is a micro filter, which is found in-line with the pressure gauges in the sample gas line. This filter should be checked once per year for any soot buildup. If soot is present in the filter, then the unit should be replaced.

4. **Sample Pump** - If after all the above mentioned components of the gas sampling system have been cleaned and/or replaced and clogging still persists, the gas sample pump may need to be cleaned, serviced (e.g., replacing pump head), or replaced. It is a best practice to run the sample pump monthly for at least 10 minutes between test series to prevent the pump head from losing flexibility, which will result in lower sample line pressure.

#### **B. Ductwork**

At a minimum, the inside of the ductwork should be cleaned once a year of any dirt, soot, and ash. This material should be removed by brushing and vacuuming. The frequency of cleaning will depend entirely on how much testing is done and on the amount of soot produced by the test specimens. If there is a noticeable drift in the calibration constant (C-factor), particularly after a batch of sooty materials are tested, the ductwork should be cleaned at this time.

#### **C. Laser Smoke Photometer**

At a minimum, the laser smoke photometer should be cleaned once a year. The laser smoke photometer system cleaning should coincide with the ductwork cleaning. A noticeable decline in the laser intensity measurement may suggest soot build up on the optics and the laser smoke photometer should be inspected and cleaned. Within the smoke photometer itself, if only a modest soot accumulation has occurred, it is sometimes possible to blow it out without disassembly. If a significant amount of soot has occurred, then the photometer must be removed and cleaned. An optical re-alignment of the laser smoke photometer will then be required [4].

#### **D. Specimen Area**

Frequent cleaning is necessary for the area around the sample holder and the load cell platform. Material falling off the sample during testing tends to accumulate in this area and may interfere with the load cell reading. Vacuuming will normally eliminate any problem. At the same time, check that the aluminum foil protecting the Marinite board heat shield has not been moved so as to bind on the load cell.



ATF-LS-FRL Cone Calorimeter – Standard Operating Procedures	ID: 6009 Revision: 4
Authority: Technical Leader	Page: 19 of 20
Original maintained by Quality Programs; copies are uncontrolled.	

## 8. Calibration/Service Intervals

The following cone calorimeter instruments need to be calibrated or serviced by the manufacturer or an approved calibration laboratory at the indicated time intervals.

### A. Heat Flux Gauge

The heat flux gauge is sent out annually for calibration. If a problem is suspected with the heat flux gauge, it can be checked using a reference heat flux gauge. If a problem is determined prior to the 1 year service interval, then the heat flux gauge shall be sent out for service and calibration.

### B. Mass Flow Meter

The mass flow meter is sent out annually for calibration. If a problem is suspected with the meter, a normal C-factor test can be performed using methane and then a second C-factor test can be conducted using ethanol [4]. If a discrepancy exists between the C-factors, the mass flow meter shall be sent out for service and calibrated prior to the 1 year interval.

### C. Gas Analyzer

The gas analyzer is calibrated at the beginning of every test day using a zero gas and a span gas. In addition, the gas analyzer is functionally verified annually at the FRL according to manufacturer specifications. [6] If the analyzer does not pass the functional verification tests, it will be sent back to Fire Testing Technology for service. If the gas analyzer shows signs of a drift problem (e.g., has a problem maintaining a span value of 20.95% for oxygen) or any other problem prior to the annual interval, it shall be sent back to the manufacturer for service.

### D. Data Acquisition (DAQ)

The data acquisition (DAQ) unit is sent out annually for calibration. If the unit stops working or yields questionable results prior to the 1 year service time period, then the unit shall be sent out for service and calibration.

### E. Load Cell

The load cell is checked or set daily using calibrated weights. In addition, the load cell is functionally verified annually. If a problem is suspected with the load cell, replace with the spare calibrated load cell and send the unit out for service and calibration. Refer to the FTT Load Cell Setup Procedure for configuration of a new load cell [1].

### F. Differential Pressure Transducer

The differential pressure transducer is calibrated annually. If a problem is suspected with the transducer, send the unit out for service and calibration.

### G. Atmospheric Pressure Transducer

If used, the atmospheric pressure transducer is calibrated annually. If a problem is suspected with the transducer, send the unit out for service and calibration.



ATF-LS-FRL Cone Calorimeter – Standard Operating Procedures	ID: 6009 Revision: 4
Authority: Technical Leader	Page: 20 of 20
Original maintained by Quality Programs; copies are uncontrolled.	

## 9. References

1. Fire Testing Technology Limited, Cone Calorimeter - Standard Operating Procedures (SOP), 2011
2. ASTM 1354-17, *Standard Test Method for Heat and Visible Smoke Release Rates for Materials and Products Using an Oxygen Consumption Calorimeter*, ASTM International, West Conshohocken, PA, 2017
3. ISO 5660-1, *Reaction-to-fire tests -- Heat release, smoke production and mass loss rate - Part 1: Heat release rate (cone calorimeter method)*, International Organization for Standardization, Geneva, Switzerland, 2015
4. Fire Testing Technology Limited, *User's Guide for the Cone Calorimeter*, Issue 1.7a, September 2001
5. Fire Testing Technology Limited, *User's Guide for FTT Load Cell Attachment*, Issue 2.0, September 2010
6. ATF FRL Standard Operating Procedure, Servomex Gas Analyzer Functional Verification, (ID 8000)



ATF-LS-FRL Differential Pressure - Averaging Velocity Probes - Standard Operating Procedure	ID: 1589 Revision: 4
Authority: Technical Leader	Page: 1 of 3
Original maintained by Quality Programs; copies are uncontrolled.	

## 1. Scope

This document contains the Standard Operating Procedure (SOP) for averaging velocity probes that use differential pressure to measure velocity at the Bureau of Alcohol, Tobacco, Firearms and Explosives (ATF) Fire Research Laboratory (FRL). This SOP does not apply to averaging velocity probes that are integral with existing/purchased equipment.

## 2. Required Supplies

- A. Differential Averaging Velocity Probe
- B. Differential pressure transducer with appropriate input range
- C. Tubing of appropriate size and material
- D. Thermocouple
- E. Electrical power for the pressure transducer per the manufacturer's specifications
- F. Data acquisition hardware
- G. Data acquisition connectivity
- H. FireTOSS client computer
- I. Plumbing and Electrical/Data Connections

## 3. Start-Up and Pre-Test

- A. Mount velocity probe in desired location.
- B. Place thermocouple near inlet of velocity probe, without obstructing the inlet port.
- C. Connect differential pressure probe to transducer using plastic or metal tubing.
- D. If using multiple probes, connect total and static pressure tubing using tee connections and make a single run for each to the transducer.
- E. Connect pressure transducer to power supply.
- F. Connect pressure transducer and thermocouple to data acquisition module.
- G. Connect data acquisition module to FireTOSS network.
- H. The calibration marking on the pressure transducer shall be checked to confirm that the instrument is calibrated.
- I. Pressure transducers shall be connected to the data acquisition hardware using the smallest input range that will bound the output range of the transducer.
- J. Pressure lines connected to the probe shall be protected if it is anticipated that they will be exposed to excessive heat or pressure during the experiment.



ATF-LS-FRL Differential Pressure - Averaging Velocity Probes - Standard Operating Procedure	ID: 1589 Revision: 4
Authority: Technical Leader	Page: 2 of 3
Original maintained by Quality Programs; copies are uncontrolled.	

- K. Perform functional verification of:
1. Thermocouple with ambient.
  2. Pressure transducer with ambient.

## 4. Experiment Procedures

### A. Prior to First Test of Series

1. A zero pressure baseline shall be recorded with the pressure transducer prior to conducting experiments.
  - During the baseline reading the high and low pressure ports of the pressure transducer shall be directly connected (cross port).
  - The baseline value shall be the average pressure measured during a period with a minimum 2-minute duration.
2. Following the baseline test, the ports on the pressure transducer shall be opened to each of the two probe fittings.
3. Verify that the zero pressure baseline has been recorded on the FireTOSS data sheet.

### B. Prior to Each Test

1. Perform functional verification of the pressure transducer and thermocouple with ambient.
2. Update FireTOSS data sheet with the Experiment ID of the baseline test.

### C. During Test

1. Monitor the output of the pressure transducer and the thermocouple shall be recorded for the duration of the experiment.
2. Exception – When the velocity probe must be removed prior to the end of the experiment due to experiment design or impending damage to the instrument. The elapsed time at which the probe was removed and the reason for instrument removal shall be recorded on the data sheet.

## 5. Shut Down and Post-Test

- A. If an instrument was taken out of service during a test, update the out of service time and out of service reason fields on the FireTOSS data sheet and redo the calculations.
- B. After the experiment, velocity probes located in areas where they may have been damaged shall be examined for visible damage or surface dirt.
- C. If surface dirt is observed, the accumulated soot shall be removed, and lines shall be blown out with compressed air. If the probe is physically damaged, it shall be taken out of service until it has been repaired.



ATF-LS-FRL Differential Pressure - Averaging Velocity Probes - Standard Operating Procedure	ID: 1589 Revision: 4
Authority: Technical Leader	Page: 3 of 3
Original maintained by Quality Programs; copies are uncontrolled.	

D. If conditions occurred, either during the test or following the test, that could potentially affect the performance of the instrument, a functional verification shall be performed on the pressure transducer and thermocouple.

## 6. Maintenance

- Check probes to ensure pressure ports are clear of obstructions.

## 7. Calibration

- All instrumentation associated with the differential pressure point velocity measurement instrumentation shall be calibrated annually.



ATF-LS-FRL Differential Pressure - Point Velocity Probes - Standard Operating Procedure	ID: 1590 Revision: 4
Authority: Technical Leader	Page: 1 of 3
Original maintained by Quality Programs; copies are uncontrolled.	

## 1. Scope

This document contains the Standard Operating Procedures for point velocity probes that use differential pressure to measure velocity during experiment conducted by the Bureau of Alcohol, Tobacco, Firearms and Explosives (ATF) Fire Research Laboratory (FRL). This document does not apply to point velocity probes that are integral with purchased equipment (e.g., cone calorimeter).

## 2. Required Supplies

- A. Differential Pressure Probe
  - Bi-directional probe
  - Pitot-static probe
- B. Differential pressure transducer with appropriate input range
- C. Tubing of appropriate size and material
- D. Thermocouple
- E. Electrical power for the pressure transducer per the manufacturer's specifications
- F. Data acquisition hardware
- G. Data acquisition connectivity – ethernet cable(s)
- H. FireTOSS client computer
- I. Heat source (open flame, heater, etc.) to check thermocouple

## 3. Start Up and Pre-Test

- A. Mount velocity probe in desired location.
- B. Place thermocouple near inlet of velocity probe, without obstructing the inlet port.
- C. Connect differential pressure probe to pressure transducer using plastic or metal tubing.
- D. Connect pressure transducer to electrical power.
- E. Connect output signal of pressure transducer and thermocouple to data acquisition module.
- F. Connect data acquisition module to either the FireTOSS network or FireTOSS client computer using an ethernet cable.
  - 1. In the FRL, this connection is made to a FireTOSS port.
  - 2. For field experiments, the data acquisition module may be connected to a FireTOSS client computer.



ATF-LS-FRL Differential Pressure - Point Velocity Probes - Standard Operating Procedure	ID: 1590 Revision: 4
Authority: Technical Leader	Page: 2 of 3
Original maintained by Quality Programs; copies are uncontrolled.	

- G. The calibration marking on the pressure transducer shall be checked to confirm that the instrument is calibrated.
- H. Pressure transducers shall be connected to the data acquisition hardware using the smallest input range that will bound the output range of the transducer.
- I. Pressure lines connected to the probe shall be protected, if it is anticipated that they will be exposed to excessive heat or pressure during the experiment.
- J. Perform functional verification of:
  - Thermocouple with ambient and heat source.
  - Pressure transducer with positive pressure source,
- K. Perform functional verification of the following:
  - 1. Thermocouple
    - Ambient air
    - Heat source, such as an open flame from a lighter.
  - 2. Pressure transducer with positive pressure source.
    - Lightly blowing air is typically sufficient for flow verification.
    - Use caution when applying pressure to the probe to prevent the pressure sensor from being damaged.

## 4. Experiment Procedures

### A. Prior to First Test of Series

- 1. Conduct a baseline experiment to measure the baseline pressure values when the pressure ports are closed.
  - During the baseline reading, the high and low pressure ports of the pressure transducer shall be directly connected (i.e., cross port).
  - The baseline value shall be the average pressure measured during a period with a minimum 2-minute duration.
- 2. Following the baseline test, the ports on the pressure transducer shall be opened to each of the two probe fittings.
- 3. Verify that the zero pressure baseline has been recorded on the FireTOSS data sheet.

### B. Prior to Each Test

- 1. Perform functional verification of the pressure transducer and thermocouple.
- 2. Update FireTOSS data sheet to include the Experiment ID of the baseline experiment for the pressure transducers.



ATF-LS-FRL Differential Pressure - Point Velocity Probes - Standard Operating Procedure	ID: 1590 Revision: 4
Authority: Technical Leader	Page: 3 of 3
Original maintained by Quality Programs; copies are uncontrolled.	

### **C. During Test**

- 1) The output of the pressure transducer and the thermocouple shall be recorded for the duration of the experiment.
- 2) Exception – When the velocity probe must be removed prior to the end of the experiment due to experiment design or impending damage to the instrument. The elapsed time at which the probe was removed and the reason for instrument removal shall be recorded on the data sheet.

## **5. Shut Down and Post-Test**

- A. If an instrument was taken out of service during a test, update the out of service time and out of service reason fields on the FireTOSS data sheet and redo the calculations.
- B. After the experiment, velocity probes located in areas where they may have been damaged shall be examined for visible damage or surface dirt.
- C. If surface dirt is observed, the accumulated soot shall be removed and lines shall be blown out with compressed air. If the probe is physically damaged, it shall be taken out of service until it has been repaired.
- D. If conditions occurred, either during the test or following the test, that could potentially affect the performance of the instrument, a functional verification shall be performed on the pressure transducer and thermocouple.

## **6. Maintenance**

- Check probes to ensure pressure ports are clear of obstructions.

## **7. Calibration**

- All instrumentation associated with the differential pressure point velocity measurement instrumentation shall be calibrated annually.



ATF-LS-FRL Digital Camera - Standard Operating Procedures	ID: 1573 Revision: 5
Authority: Technical Leader	Page: 1 of 5
Original maintained by Quality Programs; copies are uncontrolled.	

## 1. Scope

This document covers the Standard Operating Procedures for digital camera use during experiments at the Bureau of Alcohol, Tobacco, Firearms and Explosives (ATF) Fire Research Laboratory (FRL).

## 2. Required Supplies

- A. Digital Camera
- B. USB cable to connect camera to laptop
- C. Method to transfer photographs from camera to laptop (e.g., USB cable, multimedia card reader)
- D. FireTOSS laptop

## 3. Start-Up and Pre-Test Procedures

- A. Verify camera has sufficient battery life remaining.
- B. Before any tests are conducted at the start of the day, synchronize the camera to FireTOSS using *either* the Nikon software or manually.
  - 1. Synchronize using Nikon Software
    - a. Plug Camera into computer using USB cable and turn camera *ON*.
    - b. When the AutoPlay Window appears, click “Import File using Nikon Transfer 2” (Figure 1).

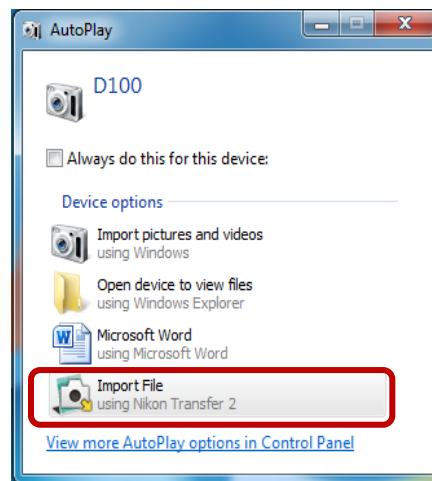
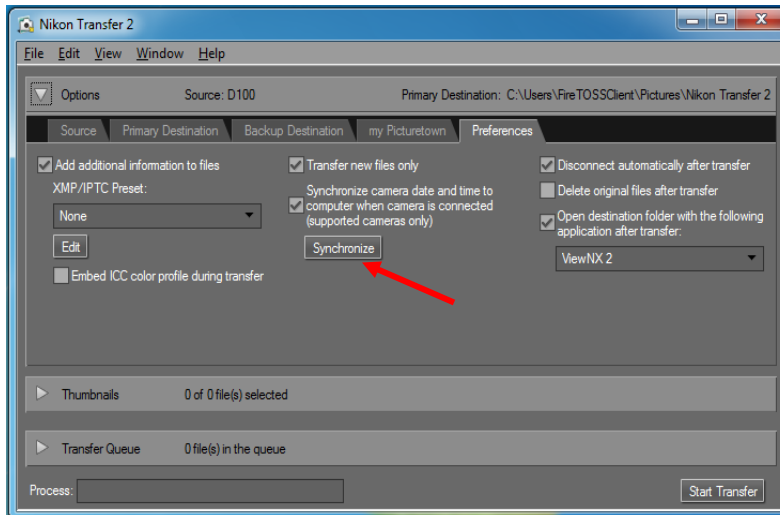

**Figure 1: AutoPlay Window**



ATF-LS-FRL Digital Camera - Standard Operating Procedures	ID: 1573 Revision: 5
Authority: Technical Leader	Page: 2 of 5
Original maintained by Quality Programs; copies are uncontrolled.	

c. Click Synchronize (Figure 2).



**Figure 2: Nikon Transfer Interface**

d. A message will appear stating the synchronized time (Figure 3). Although the Nikon Transfer Program only displays a synchronized time to the minute, the program actually synchronizes the camera to the second. Click OK.

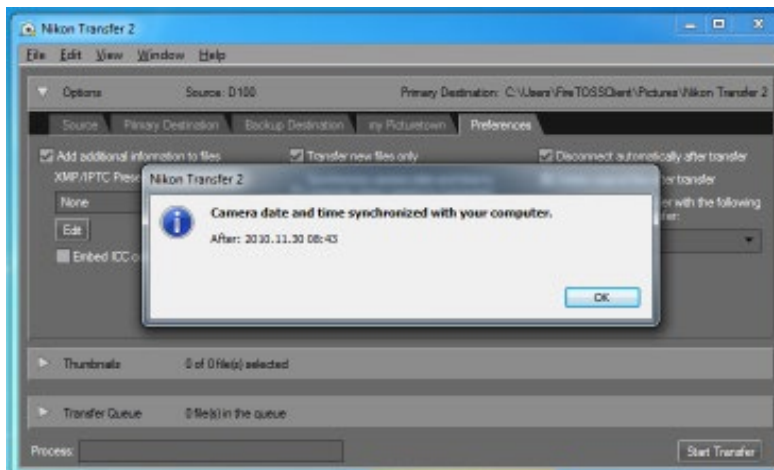

**Figure 3: Nikon Transfer Synchronization Confirmation**

e. Close Nikon Transfer and unplug camera from computer.



## 2. Synchronize Manually

- a. Open computer date/time program (Figure 4).

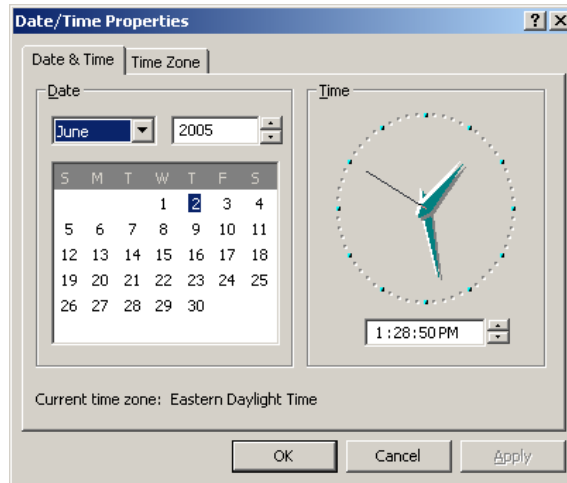

**Figure 4: Date/Time Program**

- b. Open the cameras date/time tab in menu (see cameras user manual if needed).
- c. Manually set camera clock to computer clock.

## 4. Experiment Procedures

- Take photographs before, during, and after the test, as necessary.

## 5. Shut-Down and Post-Test Procedures

### A. Upload photographs to FireTOSS

1. Use desired method to transfer photos to FireTOSS (e.g., card reader on computer, multimedia card reader, connect camera to computer using USB cord).
  - In FireTOSS, click “Import” from the menu bar and then “Upload Pictures” (Figure 5). Note that the user must be logged in to FireTOSS.



ATF-LS-FRL Digital Camera - Standard Operating Procedures	ID: 1573 Revision: 5
Authority: Technical Leader	Page: 4 of 5
Original maintained by Quality Programs; copies are uncontrolled.	

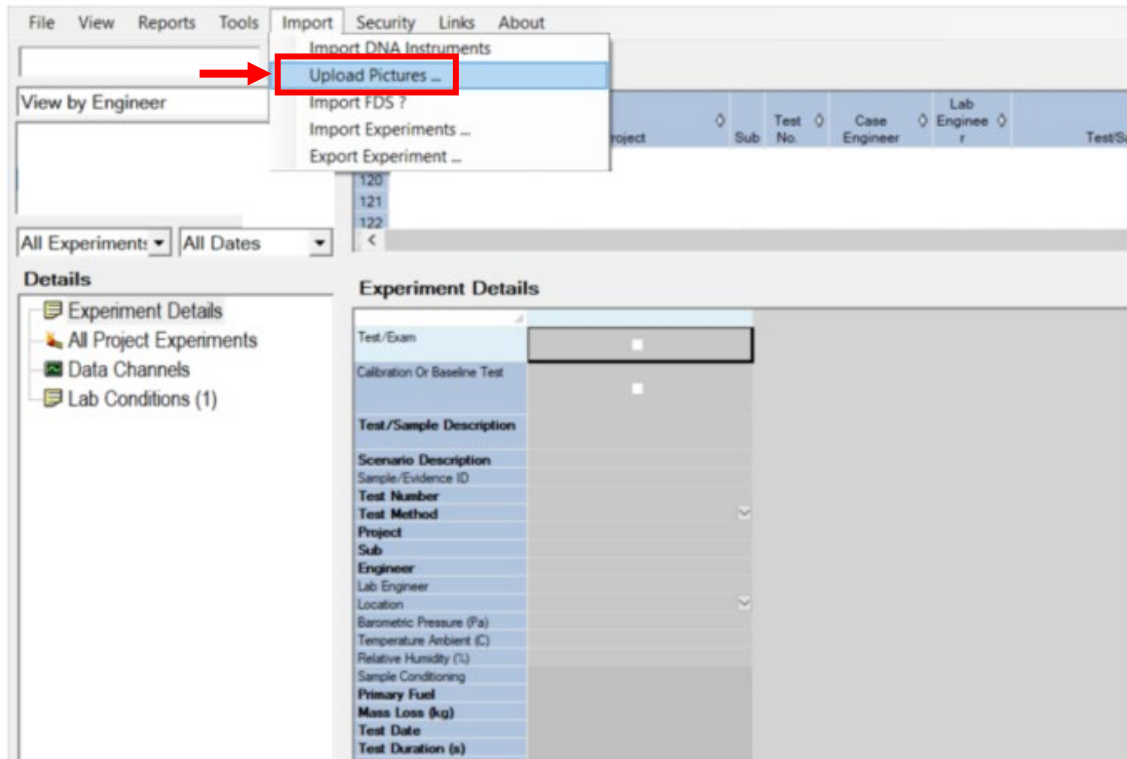
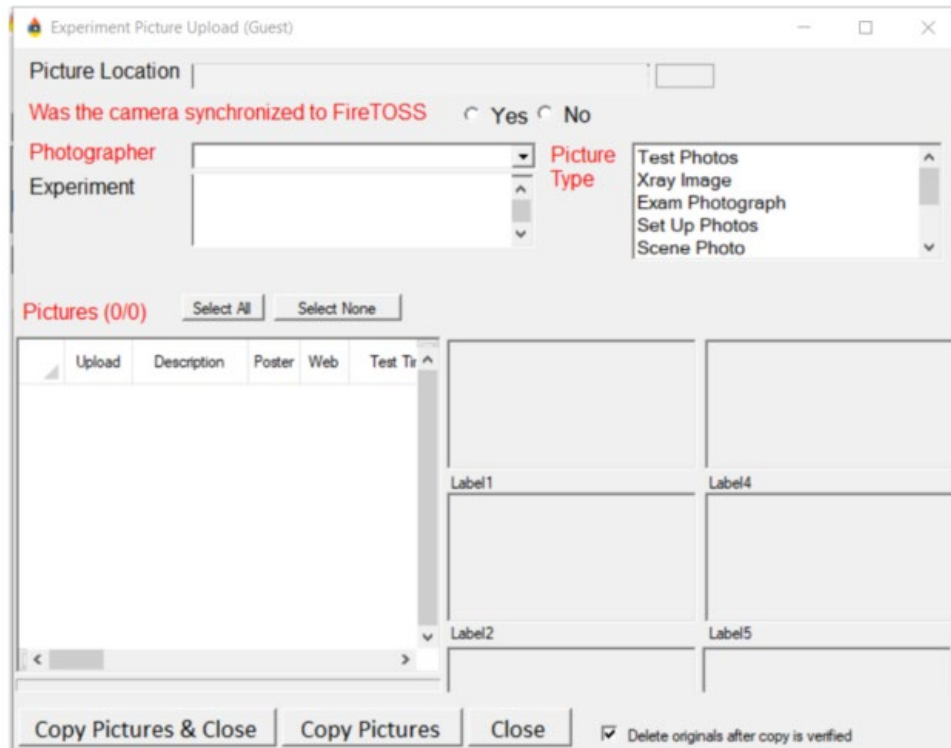

**Figure 5: How to access picture upload program from FireTOSS**

2. On the Upload Experiment Pictures box (Figure 6), enter the following information:
  - a. Specify the directory where the photos are located.
  - b. Select FireTOSS synchronization status.
  - c. Select Photographer.
  - d. Verify correct Experiment ID is selected.
  - e. Select Picture Type.
  - f. Select photos to upload.
  - g. Determine if you want to delete original pictures after copy is verified.
  - h. Copy pictures (and close).



ATF-LS-FRL Digital Camera - Standard Operating Procedures	ID: 1573 Revision: 5
Authority: Technical Leader	Page: 5 of 5
Original maintained by Quality Programs; copies are uncontrolled.	



**Figure 6: Picture Upload program**

## **6. Maintenance Procedures**

- Change battery when low.
- Periodically clean lens of camera.

## **7. Calibration Procedure/Accuracy**

- Digital cameras do not require calibration.
- Synchronize the camera clock with FireTOSS at the start of each day prior to any tests being conducted.
- Internal clock of a digital camera must be accurate to 1 second within a 24 hour period.

## **8. Technical References**

- For more information, refer to appropriate camera model User's Manual.



ATF-LS-FRL Engineering - Examinations of Items	ID: 14047 Revision: 1
Authority: Technical Leader	Page: 1 of 2
Original maintained by Quality Programs; copies are uncontrolled.	

**1. Title:** Procedure for the Examination of Items

**2. Scope:**

- 2.1. This document establishes the procedures for performing and documenting examinations of items pertinent to ATF investigations.
- 2.2. This guideline is generally based on the most recent version of the following standards or guides:
  - 2.2.1. ASTM E860 – Standard Practice for Examining and Preparing Items That Are or May Become Involved in Criminal or Civil Litigation
- 2.3. This document was developed by the Fire Research Laboratory as an internal, working document. This document was not developed with the intent of setting a standard for other laboratories. While this document may be a helpful guide for other forensic laboratories in developing their management system requirements, they were designed for use specifically by the Fire Research Laboratory.

**3. Description:**

- 3.1. The Fire Research Laboratory examines items to help answer questions related to ATF investigations.
- 3.2. These examinations may take place at the FRL, at an ATF field office or facility, at an incident scene, or other remote location.

**4. Uncertainty**

- 4.1. Where possible and necessary, uncertainty should be addressed in the engineering report associated with the examination.

**5. Procedure**

*5.1. Safety*

- 5.1.1. The examiner shall follow the requirements of the FRL Safety Manual.

*5.2. Physical Items*

- 5.2.1. Items shall be handled according to ATF-LS-7.4 (Handling of Test Items).
- 5.2.2. The examination of items shall be documented in a manner that captures the packaging type and condition (if applicable), the condition of the items as received, any alterations made by the examiner, and observations made during the examination, as per ATF-LS-7.5 (Technical Records).
- 5.2.3. The examiner should attempt to determine any change(s), alteration(s), or contamination of the items subsequent to the incident, and document those findings (ASTM E860 2022 Section 5.1.2).
- 5.2.4. Certain characteristics cannot be determined without destructive testing. Non-destructive tests and examinations should be carried out prior to any destructive testing, and destructive testing should be kept to a minimum, and thoroughly documented. If exemplars can be used instead of the subject items, then exemplars



ATF-LS-FRL Engineering - Examinations of Items	ID: 14047 Revision: 1
Authority: Technical Leader	Page: 2 of 2
Original maintained by Quality Programs; copies are uncontrolled.	

should be used to minimize consumption or alteration of the subject item (ASTM E860 2022 Section 5.2).

- 5.2.5. If proposed tests, examinations, or other actions are likely to alter the nature, state, or condition of the item(s) so as to preclude or limit additional examination or testing, the examiner should:
  - 5.2.5.1. Notify the customer that the proposed examination is likely to alter the nature, state, or condition of the item(s) so as to preclude or limit additional examination or testing of the item(s) (ASTM E860 2022 Section 5.3.2).
  - 5.2.5.2. Obtain permission from the customer to proceed with the destructive examination and obtain any further guidance from the customer as necessary.
  - 5.2.5.3. Document the reasons for the destructive examination in the examiner's notes and/or case file (ASTM E860 2022 Section 5.3.5).
  - 5.2.5.4. Document alterations to the item(s) with notes and photographs.
- 5.2.6. If applicable, upon completion of the examination, the items shall be repackaged per ATF-LS-7.4 (Handling of Test Items).

## 6. Documentation

- 6.1. The methods used and results obtained during an examination, disassembly, measurements or testing shall be documented (ASTM E860 2022 Section 6.1).
- 6.2. Documentation of an examination may include contemporaneous notes, photographs, video, radiographic (x-ray) imaging, computed tomography (CT) scans, and microscopic imaging, or other applicable techniques as required.
- 6.3. Any new items resulting from the examination shall be identified according to ATF-LS-7.4 (Handling of Test Items).
- 6.4. Photographic documentation should be of sufficient resolution to preserve the essential aspects of the appearance of the item(s) being photographed and should be capable of producing images that can be reproduced an enlarged (ASTM E1188 2023 Section 3.3.3).

## 7. References

- 7.1. ASTM E1188- Standard Practice for Collection and Preservation of Information and Physical Items by a Technical Investigator
- 7.2. ASTM E860 – Standard Practice for Examining and Preparing Items That Are or May Become Involved in Criminal or Civil Litigation



ATF-LS-FRL Engineering - Leak and Flow Testing	ID: 14048 Revision: 1
Authority: Technical Leader	Page: 1 of 4
Original maintained by Quality Programs; copies are uncontrolled.	

1. **Title:** Procedure for Leak and Pressure Testing of Gas Systems and Components
2. **Scope:**
  - 2.1. This document sets the procedure for the testing of fuel gas systems and components.
  - 2.2. This document is to be used in conjunction with *ATF-LS-FRL Engineering – Scene Examinations* and *ATF-LS-FRL Engineering – Examinations of Items*.
  - 2.3. This document is generally based on the most recent version of the following standards or guides:
    - 2.3.1. NFPA 54 – National Fuel Gas Code
    - 2.3.2. NFPA 58 – Liquefied Petroleum Gas Code
  - 2.4. This document was developed by the Fire Research Laboratory as an internal, working document. This document was not developed with the intent of setting a standard for other laboratories. While this document may be a helpful guide for other forensic laboratories in developing their management system requirements, they were designed for use specifically by the Fire Research Laboratory.
3. **Description:**
  - 3.1. The Fire Research Laboratory (FRL) assists with the investigation of fire and explosion incidents.
  - 3.2. These examinations may include scene examinations in the field and testing of components at the FRL.
  - 3.3. Investigations involving gas systems and appliances may require pressure or leak testing of appliances, devices, or piping system components.
4. **Uncertainty**
  - 4.1. Where possible and necessary, uncertainty should be addressed in the engineering report associated with the examination.
5. **Equipment**
  - 5.1. The equipment required to conduct leak and flow testing may include:
    - 5.1.1. Assorted tools
    - 5.1.2. A gas supply (i.e. an air compressor or compressed gas cylinder)
    - 5.1.3. Flow meters
    - 5.1.4. Manometers
    - 5.1.5. Pressure gauges
    - 5.1.6. Hoses and tubing
    - 5.1.7. Assorted fittings
    - 5.1.8. Assorted paint pens or markers
6. **Procedure**
  - 6.1. Safety
    - 6.1.1. The examiner shall follow the requirements of the FRL Safety Manual.



ATF-LS-FRL Engineering - Leak and Flow Testing	ID: 14048 Revision: 1
Authority: Technical Leader	Page: 2 of 4
Original maintained by Quality Programs; copies are uncontrolled.	

6.1.2. The examiner shall use caution when using the fuel gas as the test medium.

6.1.2.1. Ensure that ignition sources are secured and that switches/flashlights are not operated during the test.

6.1.2.2. The examiner shall use their issued gas monitor during testing for atmospheric monitoring.

6.2. Test Medium

6.2.1. The test medium shall be air, nitrogen, carbon dioxide, an inert gas, or the intended fuel gas.

6.2.2. Oxygen shall not be used as a test medium. Air shall not be used as a test medium for vessels containing flammable gas.

6.3. Test preparation

6.3.1. The examiner shall document the as-found condition of the system.

6.3.1.1. Place witness marks at all fittings and valves to denote their as-found condition at the start of the examination.

6.3.1.2. Witness marks should be placed prior to any modifications to the system.

6.3.2. Locate and isolate any broken or open piping or fittings. Plug, cap, or otherwise close these openings prior to testing. These actions should be documented.

6.3.3. The valves to all appliances should be closed prior to testing. These actions should be documented.

6.3.3.1. If a valve or appliance is damaged, the gas line may need to be cut and capped or otherwise plugged prior to testing. These actions should be documented.

7. Pressure Tests (Leak Test)

7.1.1. Test pressure shall be measured with a device designed to read or indicate a pressure loss due to leakage during the test.

7.1.2. The source of pressure shall be isolated before the pressure tests are made.

7.1.3. The test pressure should not exceed the maximum allowable working pressure of the system or its components.

7.1.4. Using the utility gas meter

7.1.4.1. A pressure test using the utility gas meter can be done if the meter is undamaged and has a test dial. Prior to the test, the meter should be examined to ensure it is in proper operating condition and has not been bypassed.

7.1.4.2. A leak test can be done by observing the test dial of the meter to determine if gas is passing through the meter. The duration of this test is dependent on the resolution of the meter.

Test Observation Time Based on Dial Style	
Dial Style (ft <sup>3</sup> )	Minimum Test Time (min)
0.25	5
0.5	5
1	7
2	10



ATF-LS-FRL Engineering - Leak and Flow Testing	ID: 14048 Revision: 1
Authority: Technical Leader	Page: 3 of 4
Original maintained by Quality Programs; copies are uncontrolled.	

5	20
10	30

- 7.1.4.3. If the test dial of the meter does not move after the conclusion of the test, the system should be purged, and a small leak created to verify correct operation of the meter. If the meter does not register the gas flow, the meter is defective or damaged.
- 7.1.5. Any gas system can be tested in one of the following ways:
- 7.1.5.1. Attach a pressure-measurement device at the inlet of the piping system. Pressurize the system, isolate the pressure source, and observe the pressure measurement device for a drop in pressure indicative of a leak.
- 7.1.5.2. Attach an appropriately sized in-line flow meter at the inlet of the piping system. Slowly pressurize the system. If the flow through the flow meter does not drop to zero, a leak is present.
- 7.1.6. An LP-Gas System can be tested in one of the following ways:
- 7.1.6.1. Insert a pressure measurement device between the container outlet valve and the first stage regulator or integrated two-stage regulator in the system. Admit full container pressure into the system, and then close the container valve. Release enough gas from the system to lower the pressure reading by 10 psi (69 kPa). The system should then stand for three minutes without showing a change in pressure.
- 7.1.6.2. Insert a gauge/regulator test assembly between the container outlet valve and the first-stage regulator or integrated two-stage regulator in the system.
- 7.1.6.2.1. When testing the lower pressure side of a system ( $\frac{1}{2}$  psi or less), use a gauge/regulator assembly with an inches water column scale. Install the gauge into the system downstream of the final stage regulator and pressurize the system with either fuel or other test gas to a test pressure of 9 in. w.c.  $\pm$   $\frac{1}{2}$  in. w.c. (2.2 kPa  $\pm$  0.1 kPa). Observe the gauge/manometer for a pressure change. If fuel gas is used to pressurize the system to full operating pressure, close the container service valve and release enough gas from the system to reduce the pressure to the test pressure. This ensures all regulators in the system upstream from the test point are unlocked and that a leak in the system is communicated to the gauging device. The gauging device should indicate no loss or gain of pressure for three minutes.
- 7.1.6.2.2. When testing the first stage regulator, use a 30 psi (207 kPa) gauge on the downstream side of the first-stage regulator or at the intermediate pressure tap of an integrated two-stage regulator. Admit normal operating pressure to the system and then close the container outlet valve. Release enough gas from the system to lower the pressure on the gauge by at least 2 psi (13.8 kPa) so that the first-stage regulator is unlocked. The system should be allowed to stand for three minutes without an increase or decrease in the pressure gauge reading.



ATF-LS-FRL Engineering - Leak and Flow Testing	ID: 14048 Revision: 1
Authority: Technical Leader	Page: 4 of 4
Original maintained by Quality Programs; copies are uncontrolled.	

7.1.6.3. If a leak is indicated by the pressure test, all equipment or outlets supplied by the system should be examined to see whether they are closed and do not leak. If they are found to be tight, the piping system has a leak.

## 7.2. Detection of Leaks

7.2.1. Leakage can be located with a combustible gas detector, a leak detection fluid, or other appropriate leak detection method.

## 8. Flow Testing (Quantifying a Leak)

8.1. If present, one of the following methods may be used to quantify the leak.

8.1.1. Undamaged utility gas meter.

8.1.1.1. Note the current reading on the meter dials.

8.1.1.2. Start a timer and allow the test medium to flow through the system for a specified time (e.g., 5 minutes).

8.1.1.3. At the end of the test, stop the flow of the test medium and record the new meter readings.

8.1.1.4. Calculate the amount of gas that flowed during the test period and convert to the proper units (e.g., standard cubic feet per minute).

8.1.2. Flow meters.

8.1.2.1. Install the flow meters upstream from the pressure regulator(s) to minimize flow restrictions.

8.1.2.2. Allow the test medium to flow into the system, observing the flow meter in the process.

8.1.2.2.1. Account for any gas property differences between the test medium, the flow meters, and the fuel gas.

## 9. Documentation

9.1. Document the methods used and results obtained during the examination, disassembly or testing of an appliance, device, or building system.

9.2. Documentation of an examination may include contemporaneous notes, photographs, video, radiographic (x-ray) imaging, or other applicable techniques as required.

9.3. Results shall be corrected for differences in temperature, pressure, or test medium properties (e.g., density).

9.3.1. Fluctuations in pressure due to temperature changes may need to be considered.

9.3.2. Some flow measurement devices measure in SCFH of air; correction from air to the test gas may need to be considered.

9.3.3. Flow measurements of a test gas may need to be corrected to accurately represent the flow of the intended fuel gas.



ATF-LS-FRL Engineering - Scene Examinations	ID: 14049 Revision: 1
Authority: Technical Leader	Page: 1 of 2
Original maintained by Quality Programs; copies are uncontrolled.	

**1. Title:** Procedure for Scene Examinations

**2. Scope:**

- 2.1. This document establishes the procedures for examining and documenting an incident scene.
- 2.2. This guideline is generally based on the most recent version of the following standards or guides:
  - 2.2.1. ASTM E1188 - Standard Practice for Collection and Preservation of Information and Physical Items by a Technical Investigator
- 2.3. This document was developed by the Fire Research Laboratory as an internal, working document. This document was not developed with the intent of setting a standard for other laboratories. While this document may be a helpful guide for other forensic laboratories in developing their management system requirements, they were designed for use specifically by the Fire Research Laboratory.

**3. Description:**

- 3.1. The Fire Research Laboratory (FRL) conducts scene examinations to help answer questions related to ATF investigations.
- 3.2. These examinations take place outside of the FRL.

**4. Uncertainty**

- 4.1. Where possible and necessary, uncertainty should be addressed in the engineering report associated with the examination.

**5. Procedure**

5.1. *Safety*

- 5.1.1. The examiner shall follow the requirements of the FRL Safety Manual.

5.2. *Scene Examination*

- 5.2.1. The scope of the examination should be discussed with the customer prior to the commencement of work.
- 5.2.2. Collect information related to events and conditions before during, and after the incident. This may include interviewing occupants, utility company personnel, first responders, or other witnesses (ASTM E1188 2023 Section 3.1).
- 5.2.3. The examination should be conducted in a manner that identifies, documents, and protects physical evidence related to the incident (ASTM E1188 2023 Section 3.2.1).
  - 5.2.3.1. Evidence collection shall be performed by the customer or their designee. FRL staff may consult on evidence collection activities.
- 5.2.4. Document conditions that prevent or interfere with the scene examination or preservation of evidence. These may include hazardous conditions, accessibility limitations, weather, or other existing complications (ASTM E1188 2023 Section 3.2.2.).



ATF-LS-FRL Engineering - Scene Examinations	ID: 14049 Revision: 1
Authority: Technical Leader	Page: 2 of 2
Original maintained by Quality Programs; copies are uncontrolled.	

- 5.2.5. Attempt to determine any change(s), alteration(s), or contamination of the evidence subsequent to the incident, and document those findings (ASTM E860 2022 Section 5.1.2).
- 5.2.6. Certain characteristics cannot be determined without destructive testing. Non-destructive tests and examinations should be carried out prior to any destructive testing. Destructive testing should be thoroughly documented and kept to a minimum. If exemplars can be used instead of the subject items, then exemplars should be used to minimize consumption or alteration of the subject item (ASTM E860 2022 Section 5.3.1).
- 5.2.7. If proposed tests, examinations, or other actions are likely to alter the nature, state, or condition of the evidence so as to preclude or limit additional examination or testing, the examiner should:
  - 5.2.7.1. Notify the customer that the proposed examination is likely to alter the nature, state, or condition of the evidence so as to preclude or limit additional examination or testing of the evidence (ASTM E860 2022 Section 5.3.2).
  - 5.2.7.2. Obtain permission from the customer to proceed with the destructive examination and obtain any further guidance from the customer as necessary.
  - 5.2.7.3. Document the reasons for the destructive examination in the examiner's notes and/or case file (ASTM E860 2022 Section 5.3.5).
  - 5.2.7.4. Document all alterations to potential evidence, building systems, or other items of interest with notes and photographs.

## 6. Documentation

- 6.1. The examination shall be documented in a manner that captures the work performed.
- 6.2. Document the methods used, and results obtained during the examination, testing, or disassembly of an appliance, device, or building system.
  - 6.2.1. For items that are disassembled or subjected to destructive testing, each step of the process should be documented with contemporaneous photographs or video (ASTM E1188 2023 Section 3.3.2).
- 6.3. Documentation of an examination may include contemporaneous notes, photographs, video, radiographic (x-ray) imaging, or other applicable techniques as required.
- 6.4. Photographic documentation should be of sufficient resolution to preserve the essential aspects of the appearance of the evidence being photographed and should be capable of producing images that can be reproduced an enlarged (ASTM E1188 2023 Section 3.3.3).

## 7. References

- 7.1. ASTM E860 – Standard Practice for Examining and Preparing Items That Are or May Become Involved in Criminal or Civil Litigation
- 7.2. ASTM E1188- Standard Practice for Collection and Preservation of Information and Physical Items by a Technical Investigator



ATF-LS-FRL Engineering - Smoke Alarm Evidence Examinations	ID: 14045 Revision: 3
Authority: Technical Leader	Page: 1 of 50
Original maintained by Quality Programs; copies are uncontrolled.	

**1. Title:** Procedure for the Examination of Smoke Alarms for Enhanced Soot Deposition

**2. Scope:**

**2.1.** This procedure document establishes the methodology that FRL engineers use to perform examinations on smoke alarms for enhanced soot deposition (ESD). This document lays out minimum requirements for performing and documenting these examinations.

**2.2.** This document is to be used in conjunction with *ATF-LS-FRL Engineering – Examinations of Items*.

**2.3.** This procedure document is based on the methodology and validation presented in the following publications:

2.3.1. Phelan, P., “An Investigation of Enhanced Soot Deposition on Smoke Alarm Horns”, Master of Science Thesis, Worcester Polytechnic Institute, May 2004.

2.3.2. Mealy, C.L. and Gottuk, D.T., “Full-Scale Validation Tests of a Forensic Methodology to Determine Smoke Alarm Response”, *Fire Technology* 47:275-289, Springer Science + Business Media, LLC, 2011.

2.3.2.1.A decision tree for examination is provided in Figure 1.

**2.4.** This document was developed by the Fire Research Laboratory as an internal, working document. This document was not developed with the intent of setting a standard for other laboratories. While this document may be a helpful guide for other forensic laboratories in developing their management system requirements, they were designed for use specifically by ATF Laboratories.

**3. Description:**

**3.1.** The Fire Research Laboratory (FRL) examines smoke alarms to determine if a smoke alarm activated and provided audible notification in the presence of smoke.

**3.2.** These examinations may take place at the FRL, at an ATF field office or facility, at a scene, or other remote location.

**4. Uncertainty**

**4.1.** Uncertainty of the examination methodology is detailed in the peer reviewed publication listed in 2.3.2



ATF-LS-FRL Engineering - Smoke Alarm Evidence Examinations	ID: 14045 Revision: 3
Authority: Technical Leader	Page: 2 of 50
Original maintained by Quality Programs; copies are uncontrolled.	

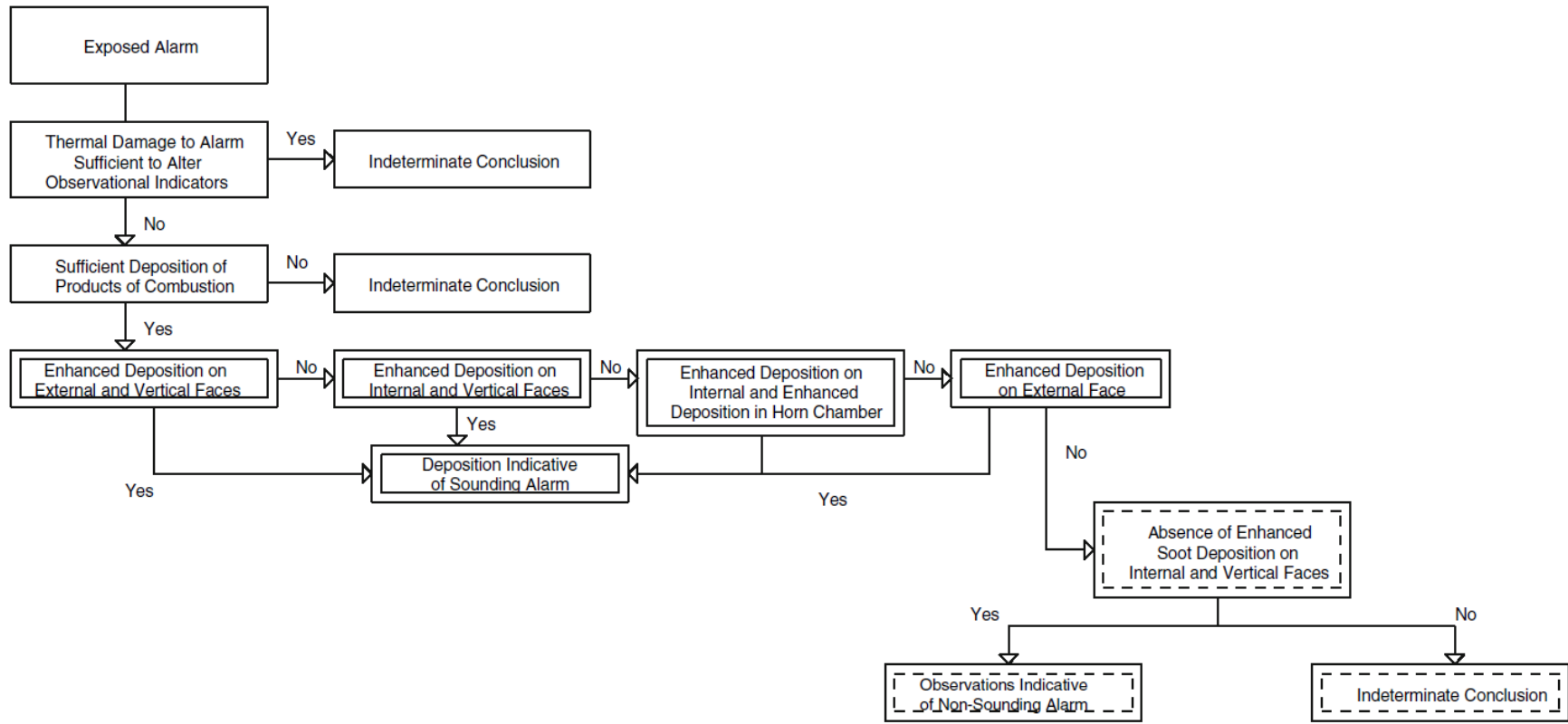

Figure 1. Decision tree developed based upon Phelan et al. heuristics [2.3.1]. Decisions enclosed within double-solid line boxes are those associated with the Sounding heuristic while decisions enclosed in single-solid, single-hatched line boxes are those associated with the non-sounding heuristic [2.3.2].



ATF-LS-FRL Engineering - Smoke Alarm Evidence Examinations	ID: 14045 Revision: 3
Authority: Technical Leader	Page: 3 of 50
Original maintained by Quality Programs; copies are uncontrolled.	

## 5. Procedure

### 5.1. Safety

5.1.1. The examiner shall follow the requirements of the FRL Safety Manual.

### 5.2. Physical Evidence

5.2.1. The physical evidence procedures detailed in *ATF-LS-FRL Engineering – Examinations of Items* are applicable to these examinations.

5.2.2. Remove the smoke alarm from the submitted container.

5.2.3. Document the exterior of the smoke alarm, front and rear. Refer to A.1 for further guidance.

5.2.3.1. Make/Model

5.2.3.2. Sensing Type (Photoelectric/Ionization/Combination)

5.2.3.3. Battery/Battery Compartment (if applicable)

5.2.3.4. Wiring (if applicable)

5.2.3.5. Tamper seal (if applicable)

5.2.3.6. Activation/Deactivation Switch (if applicable)

5.2.4. Thermal damage to alarm sufficient to alter observational indicators.

5.2.4.1. Per 2.3.2, if the submitted smoke alarm sustained thermal damage sufficient to alter observational indicators, the examiner may, at their discretion, end the examination and render an indeterminate conclusion. Refer to A.3 for further guidance.

5.2.4.1.1. If an indeterminate conclusion is rendered, proceed to 6.1.

5.2.5. Sufficient deposition of products of combustion

Per 2.3.2, if the submitted smoke alarm lacks sufficient overall soot deposition, the examiner may, at their discretion, end the examination and render an Indeterminate conclusion. Refer to A.4 for further guidance.

5.2.5.1. If an indeterminate conclusion is rendered, proceed to 6.1.

5.2.6. Determine the horn geometry/assembly type of the smoke alarm.

5.2.6.1. Refer to A.5 for guidance on identifying the horn geometry/assembly type of the smoke alarm.

5.2.7. External Face of Horn Chamber

5.2.7.1. Examine the external face of the horn chamber for ESD in accordance with 2.3.1 and 2.3.2.

- If necessary, remove the front cover of the smoke alarm to expose the external face of the horn chamber. Refer to A.5 for further guidance.
- Refer to A.6-A.8 for further guidance on properly identifying the presence or absence of ESD on smoke alarms.
- If ESD is observed on the external face of the horn chamber, the examiner may end the examination and conclude that the observed ESD on the external face of the smoke alarm is consistent with a sounding smoke alarm in the presence of smoke (per 2.3.2).
  - Proceed to 6.1.



ATF-LS-FRL Engineering - Smoke Alarm Evidence Examinations	ID: 14045 Revision: 3
Authority: Technical Leader	Page: 4 of 50
Original maintained by Quality Programs; copies are uncontrolled.	

- If ESD is not observed on the external face of the horn chamber, proceed to 5.2.8.

#### 5.2.8. Horn Chamber Vertical Face and Interior Surfaces

5.2.8.1. Remove the piezoelectric disc from the backside of the horn chamber to expose the interior of the horn chamber.

5.2.8.2. Examine the horn chamber vertical face and interior surfaces for ESD in accordance with 2.3.1 and 2.3.2.

5.2.8.3. Refer to A.6-A.8 for further guidance on properly identifying the presence or absence of ESD on horn chamber surfaces.

- If ESD is observed on the vertical and interior faces of the horn chamber, the examiner may end the examination and conclude that the observed ESD on these faces of the horn chamber is consistent with a sounding smoke alarm in the presence of smoke (per 2.3.2).
  - Proceed to 6.1.
- If ESD is observed on the interior face and within the horn chamber, the examiner may end the examination and conclude that the observed ESD on these surfaces of the horn chamber is consistent with a sounding smoke alarm in the presence of smoke (per 2.3.2).
  - Proceed to 6.1.
- If ESD is observed solely on the vertical face or solely on the interior face of the horn chamber, the examiner may end the examination and render an indeterminate conclusion (per 2.3.2).
  - Proceed to 6.1.
- If ESD is not observed on any of the external, vertical, or internal faces of the horn chamber, the examiner may conclude that the lack of ESD on the horn chamber surfaces is consistent with a non-sounding alarm in the presence of smoke (per 2.3.2).
  - Proceed to 5.2.9.

#### 5.2.9. Non-sounding alarms

5.2.9.1. The following is not required but could be of investigative value. In the event of a “non-sounding alarm” conclusion, attempt to determine why the alarm did not sound. Causes of a non-sounding alarm include, but are not limited to:

- Wiring harness disconnected (if applicable) - additional information from the submitting agent may be required.
- Battery absent, displaced, or improperly installed - additional information from the submitting agent may be required.
- Insufficient battery charge - document the battery voltage with a multimeter (if available).
- Circuitry discontinuity - many alarms will not function with the battery compartment in the OPEN position, even when the battery otherwise appears properly installed. Artifacts of the battery compartment position at the time of exposure may be observable upon examination.



ATF-LS-FRL Engineering - Smoke Alarm Evidence Examinations	ID: 14045 Revision: 3
Authority: Technical Leader	Page: 5 of 50
Original maintained by Quality Programs; copies are uncontrolled.	

- Tamper seal broken/circuitry opened via switch - common on ten-year sealed type smoke alarms.

## 6. Documentation

- 6.1. Document the methods used, and results obtained during the examination, disassembly, or testing.
- 6.2. Documentation of an examination may include contemporaneous notes, photographs, video, radiographic (x-ray) imaging, computed tomography (CT) scans, and microscopic imaging, or other applicable techniques as required.

## 7. Reporting

### 7.1. Examination Request

- 7.1.1. Document the examination request from the submitting agent.

### 7.2. Exhibits

- 7.2.1. List each exhibit submitted.
  - 7.2.1.1. Include both the LIMS and submitting agent's exhibit numbers.

### 7.3. Examination

- 7.3.1. Document the evidence submission as received.
  - 7.3.1.1. Example: *The evidence was received in a cardboard box sealed with signed and dated evidence tape. Within the box were xx exhibits (Figure XX):*
    - *A paper bag sealed with signed and dated evidence tape identified as Exhibit #X*
  - 7.3.1.2. State the methodology used during the examination.
    - 7.3.1.2.1. Example: *The following exhibits were examined and evaluated in accordance with the methodology developed by Phelan [1] and validated by Mealy, et al. [2]. This method utilized the presence or absence of enhanced soot deposition resulting from acoustic agglomeration near the smoke alarm's horn to determine if alarm activation occurred during a fire. The methodology is summarized in the decision tree provided in Figure X.*
  - 7.3.1.3. Provide factual documentation of the examination performed on each exhibit.
    - 7.3.1.3.1. Example: *Exhibit #xxxx consisted of a First Alert Model #xx Single Station Ionization smoke alarm with 10-year sealed lithium battery. The manufacture date was xx/xx/xxxx (Figure x-Figure xx). At the time of examination, the alarm cover and battery were not present (Figure xxx). The alarm horn chamber was disassembled to facilitate further examination (Figure x-Figure xx).*



ATF-LS-FRL Engineering - Smoke Alarm Evidence Examinations	ID: 14045 Revision: 3
Authority: Technical Leader	Page: 6 of 50
Original maintained by Quality Programs; copies are uncontrolled.	

**7.4. Results**

7.4.1. Document the results of the examination.

- 7.4.1.1. Presence of battery
- 7.4.1.2. Overall soot exposure
- 7.4.1.3. Thermal deformation
- 7.4.1.4. Presence of ESD

- External Face
- Vertical Face
- Internal Face
- Within Horn Chamber

7.4.2. When multiple exhibits are examined, tabulating the results may be useful. An Example is provided in Table 1.

Table 1. Example- Examination Results Tabulation

LIMS # [Agent #]	Battery Present	Insufficient Soot Deposition OR Thermally Deformed	Horn Chamber Enhanced Soot Deposition Observations			
			External Face	Vertical Surfaces	Internal Face	Within Horn Chamber
# [#]	YES	NO	YES			
# [#]	YES	NO	YES	N/A	YES	YES
# [#]	YES	NO	NO	NO	NO	NO
# [#]	NO	TD	IND	IND	IND	IND
# [#]	NO	S	NO	NO	NO	NO

IND-Indeterminate; TD-Thermally deformed components, altering observational indicators; S-Insufficient deposition of combustion products

**7.5. Analysis**

7.5.1. Provide analysis of the results.

- 7.5.1.1. Example 1: *Enhanced soot deposition was observed on the external face, circumferentially around the horn chamber opening (Figure xx-Figure xx). This observation is consistent with a sounding alarm in the presence of smoke.*
- 7.5.1.2. Example 2: *Enhanced soot deposition was not observed on the external or internal faces of the horn chamber opening nor was it observed on the vertical surfaces of the horn chamber opening. Enhanced soot deposition was not observed within the horn chamber (Figure xx-Figure xx). These observations are consistent with a non-sounding alarm in the presence of smoke.*

7.5.1.3. Indeterminate Smoke Alarms

- Though not required, provide a reason why an indeterminate conclusion is warranted (e.g. thermal damage or horn chamber not present).



ATF-LS-FRL Engineering - Smoke Alarm Evidence Examinations	ID: 14045 Revision: 3
Authority: Technical Leader	Page: 7 of 50
Original maintained by Quality Programs; copies are uncontrolled.	

#### 7.5.1.4. Non-Sounding Smoke Alarms

- Though not required, provide a reason why the alarm did not sound (no power source, tampering, etc.) if possible.

### 7.6. Conclusions

7.6.1. Provide concise conclusions as supported by the Examination, Results, and Analysis.

7.6.1.1. The examiners may render the following conclusions based upon the examined presence or absence of ESD on the horn chamber of a smoke alarm:

- Consistent with a sounding alarm in the presence of smoke
- Consistent with a non-sounding alarm in the presence of smoke
- Indeterminate

7.6.2. Example Conclusions

7.6.2.1. The following conclusions were rendered with respect to alarm functionality in the presence of smoke:

- LIMS Exhibit #X – Consistent with a sounding alarm in the presence of smoke.
- LIMS Exhibit #XX – Consistent with a non-sounding alarm in the presence of smoke.
- LIMS Exhibit #XXX – Indeterminate



ATF-LS-FRL Engineering - Smoke Alarm Evidence Examinations	ID: 14045 Revision: 3
Authority: Technical Leader	Page: 8 of 50
Original maintained by Quality Programs; copies are uncontrolled.	

## Appendix.

**A.1.** Reaching a conclusion with respect to alarm functionality in the presence of smoke is based on a systematic approach involving the analysis of multiple alarm surfaces. The purpose of appendix photographs is to help interpret the procedure. Comparison of an examined alarm to the photographs below to reach a conclusion is not appropriate.

**A.2.** This section provides photographs to assist the examiner in properly documenting the smoke alarm, as received, during examinations. This section provides photographs to assist the examiner in properly documenting the smoke alarm, as received, during examinations.

### A.2.1. Frontside

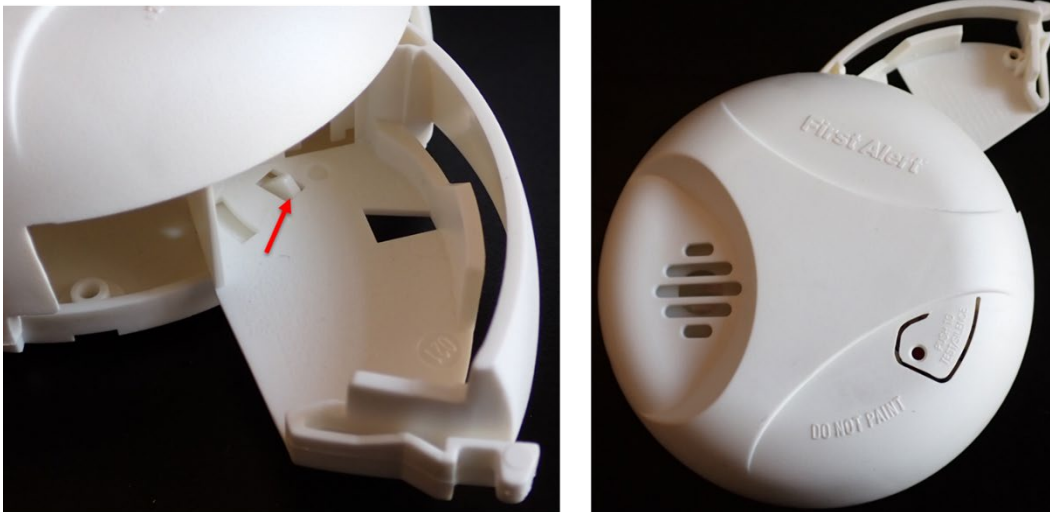

Figure 2. Example of alarm frontside documentation. Note the battery compartment is empty, and the lockout mechanism to prevent closure of the battery compartment without a battery installed.



ATF-LS-FRL Engineering - Smoke Alarm Evidence Examinations	ID: 14045 Revision: 3
Authority: Technical Leader	Page: 9 of 50
Original maintained by Quality Programs; copies are uncontrolled.	

A.2.2. Backside



Figure 3. Example of alarm backside documentation. Note the Make/Model, Sensing Type, Manufacture Date, etc.



**A.3.** This section provides photographs to assist the examiner in identifying excessive thermal damage to a smoke alarm, resulting in an indeterminate conclusion.

A.3.1. Thermal Damage to Alarm Sufficient to Alter Observational Indicators

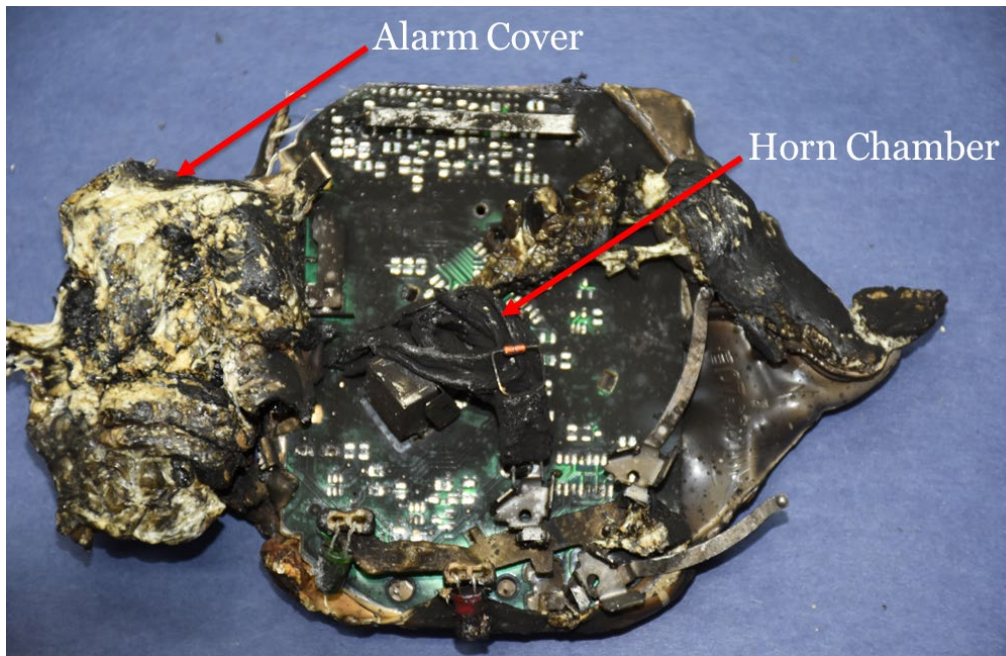

Figure 4. Example of a Smoke Alarm with Thermal Damage Sufficient to Alter Observational Indicators. For this alarm the horn chamber is present, albeit severely deformed.

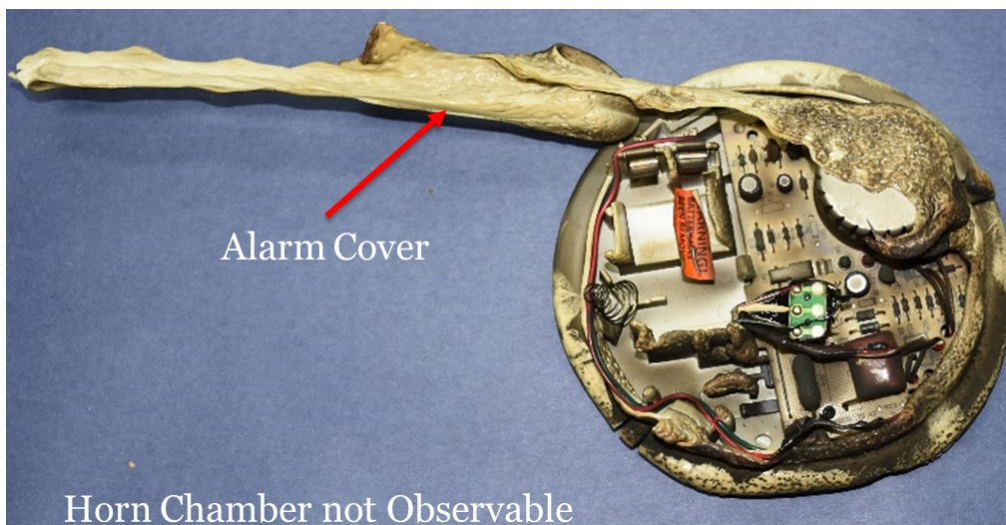

Figure 5. Example of a Smoke Alarm with Thermal Damage Sufficient to Alter Observational Indicators. For this alarm the horn chamber is not observable due to deformation on the alarm cover and horn chamber.



Figure 6. Example of a smoke alarm with thermal damage sufficient to alter observable indicators. Note the deformation and discoloration on the horn chamber.



ATF-LS-FRL Engineering - Smoke Alarm Evidence Examinations	ID: 14045 Revision: 3
Authority: Technical Leader	Page: 12 of 50
Original maintained by Quality Programs; copies are uncontrolled.	

A.4. This section provides photographs to assist the examiner in identifying sufficient deposition of products of combustion.

A.4.1. Sufficient deposition of products of combustion, examiner may proceed with examination.



Figure 7. Example of a smoke alarm with sufficient, overall depositions of products of combustion. Note the general, relatively uniform, soot staining on the entire surface of the alarm cover.



ATF-LS-FRL Engineering - Smoke Alarm Evidence Examinations	ID: 14045 Revision: 3
Authority: Technical Leader	Page: 13 of 50
Original maintained by Quality Programs; copies are uncontrolled.	

A.4.2. Insufficient deposition of products of combustion, resulting in an indeterminate conclusion.



Figure 8. Example of a smoke alarm with insufficient, overall depositions of products of combustion. Note the lack of soot staining anywhere on the alarm.



A.5. This section provides photographs to assist the examiner in properly identifying the external, vertical, and internal faces of the horn chamber on various smoke alarm assemblies during examinations.

**A.5.1. Alarm Type: Horn Chamber Integrated into the Alarm Cover**

A.5.1.1. External Face of Horn Chamber

- For this type of alarm, the external face is located on the alarm cover.

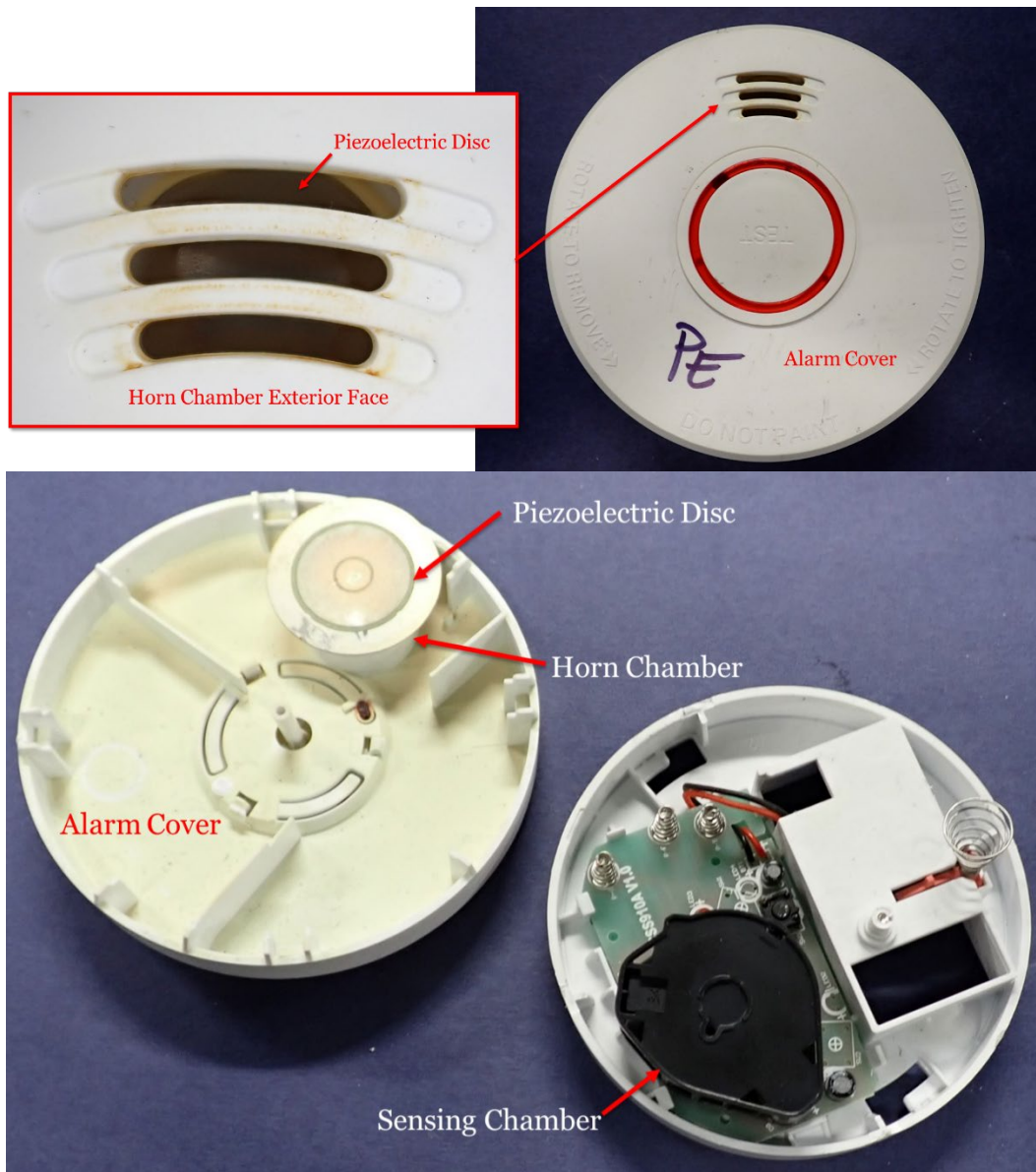

Figure 9. Example of a smoke alarm with horn chamber exterior face located on the exterior of the alarm cover. Note how the horn chamber is physically connected to the alarm cover backside (Bottom), backed by the piezoelectric disc.



A.5.1.2. Horn Chamber, Horn Chamber Vertical/Internal Faces

- The vertical face is always the sheer face which connects the external and internal faces.

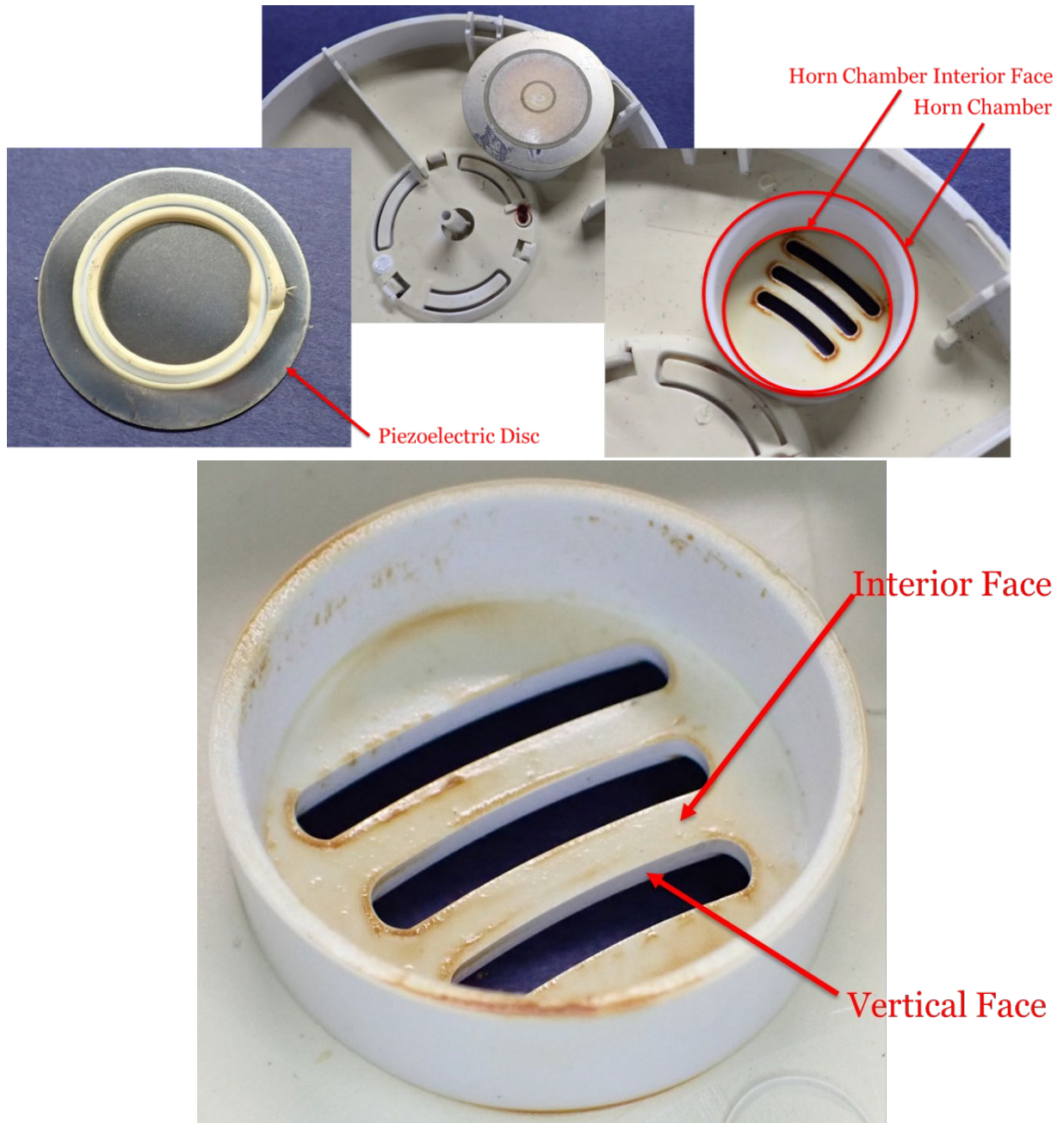

Figure 10. Example of a smoke alarm with horn chamber physically connected to the alarm cover backside the piezoelectric disc has been removed, exposing the horn chamber interior, interior and vertical faces.



**A.5.2. Alarm Type: Internal Horn Chamber**

A.5.2.1. External and vertical faces of the horn chamber located inside the alarm cover.

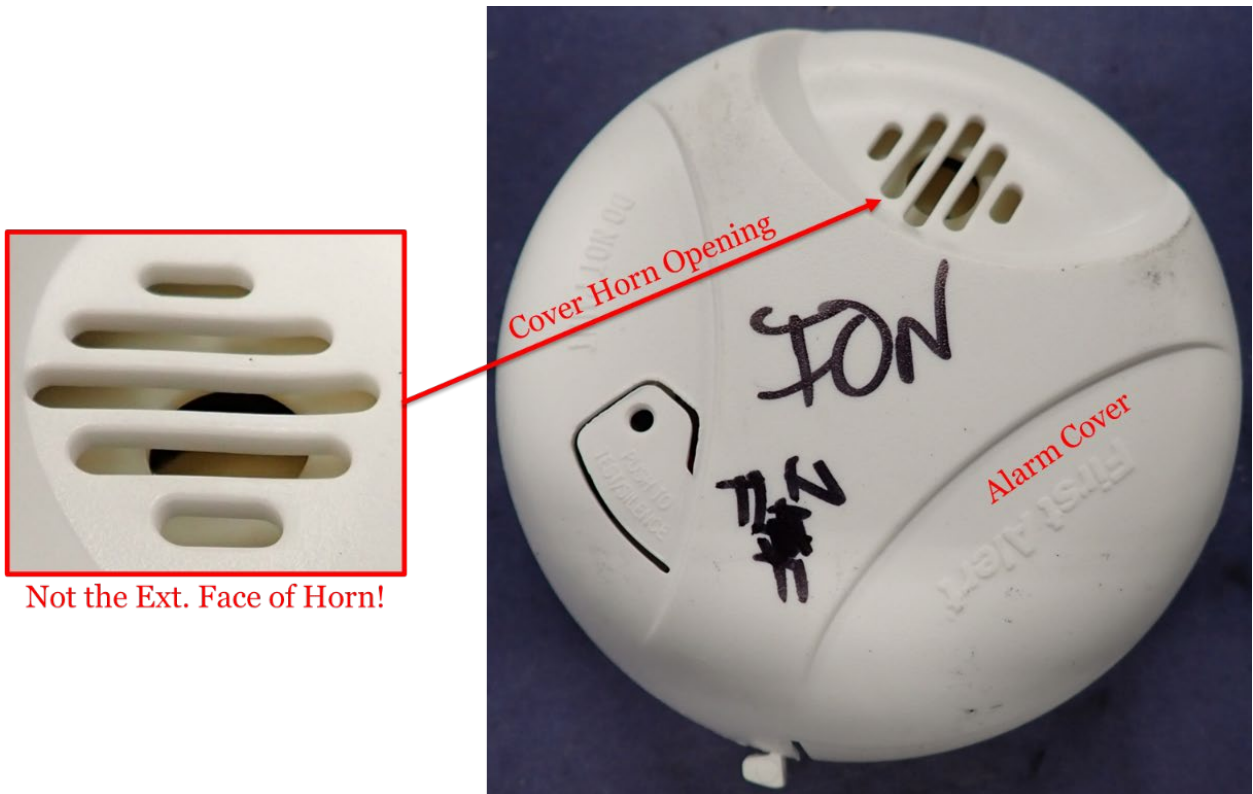

Figure 11. Example of a smoke alarm with internal horn chamber.



Figure 12. Example of a smoke alarm with internal horn chamber. Note how the horn chamber is not physically attached to the opening on the alarm cover.

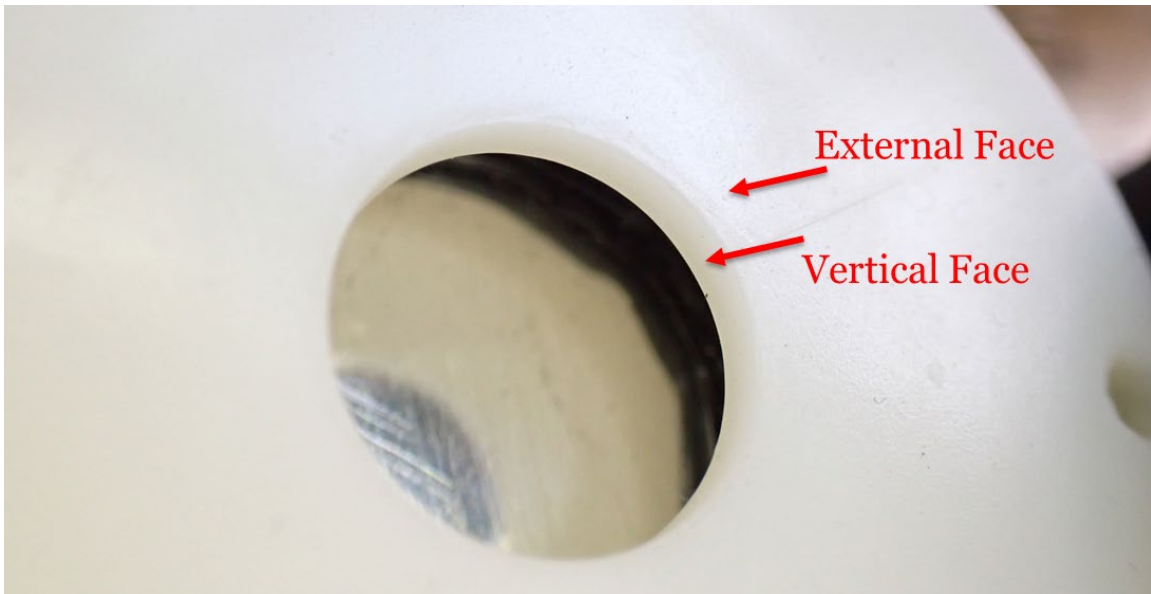
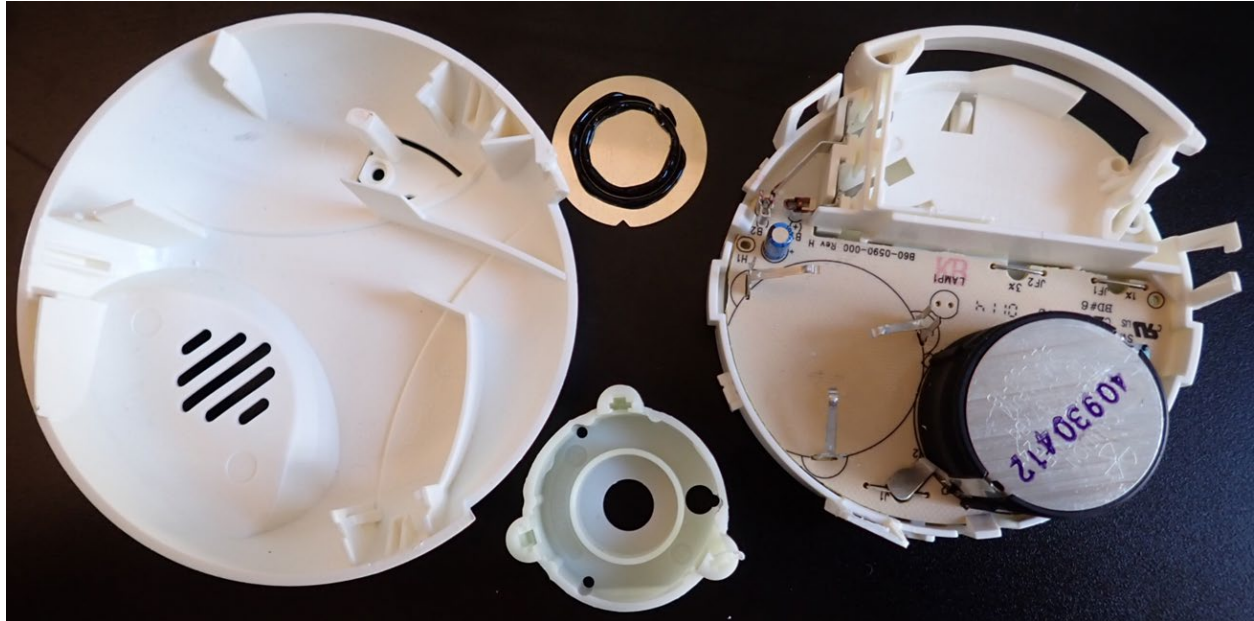

Figure 13. Zoomed in view of the horn chamber external and vertical faces. The vertical face is the sheer face connecting the exterior and interior faces.



A.5.2.2. Horn Chamber Internal Surfaces



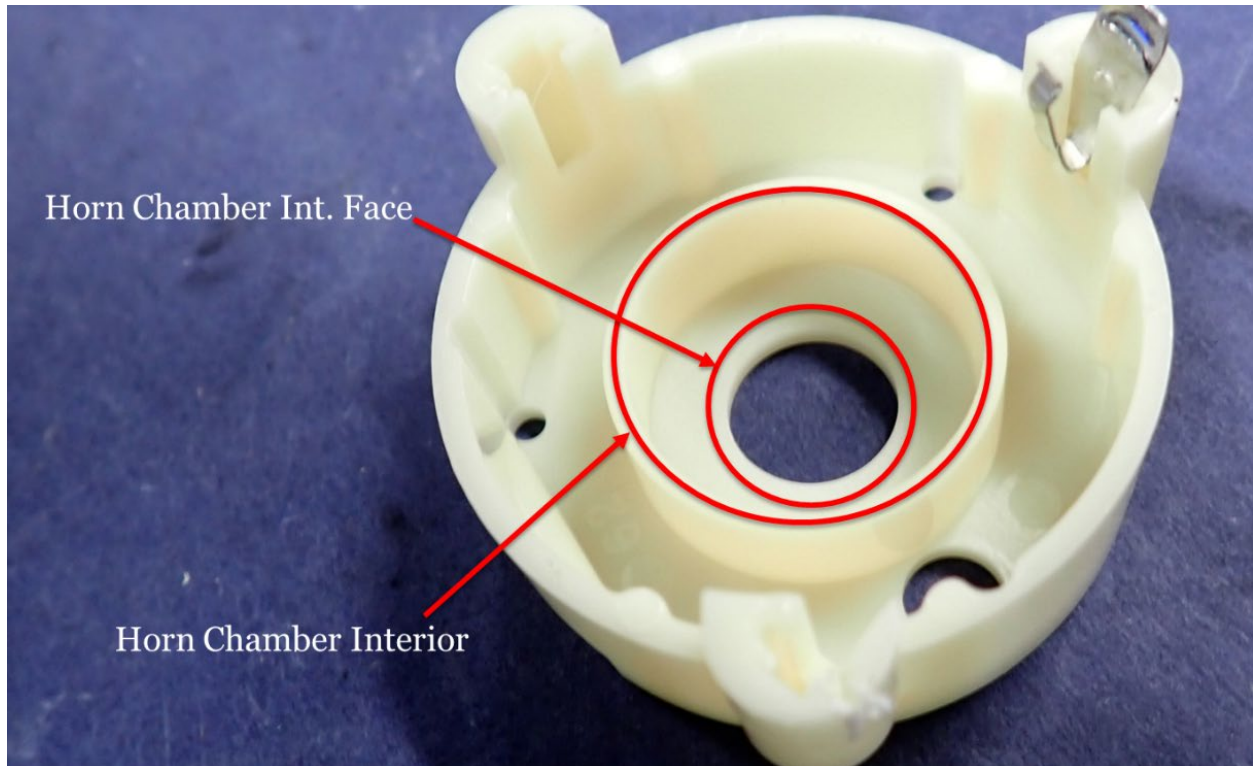

Figure 14. Example of a smoke alarm with internal horn chamber. The horn chamber has been removed from the alarm base and the piezoelectric disc has been removed, exposing the horn chamber interior surfaces.

### A.5.3. Alarm Type: Horn Chamber Intimate with Alarm Cover

#### A.5.3.1. External and Vertical Faces

- For these alarms, determining the external face is subjective.
- Best practice: Document the alarm cover opening, exterior and interior, as well as the exterior, circumferential surface of the horn chamber itself.

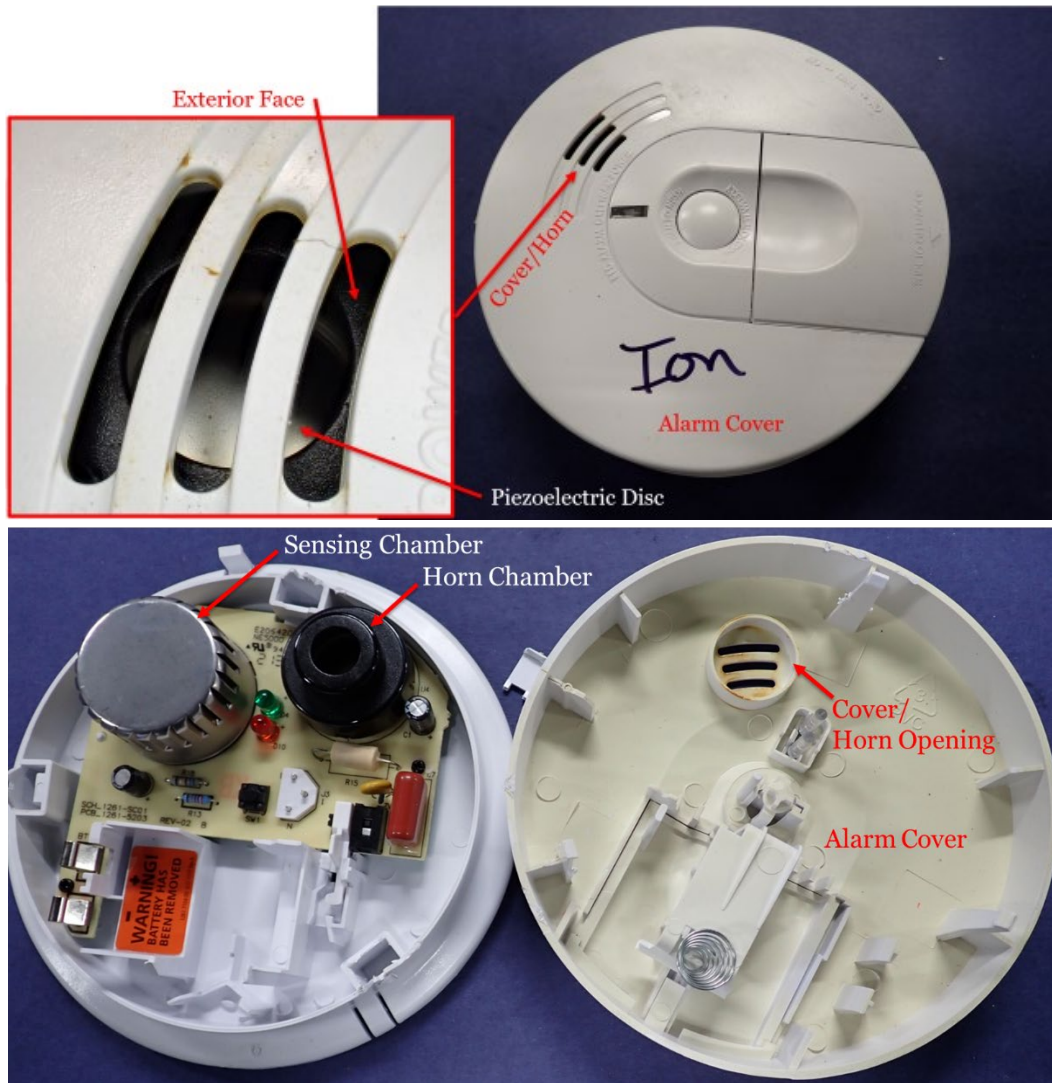

Figure 15. Example of a smoke alarm with horn chamber intimate with alarm cover opening. Note the proximity of the horn chamber opening to the alarm cover opening, and how the horn chamber extrusion fits into the inset on the alarm cover.



ATF-LS-FRL Engineering - Smoke Alarm Evidence Examinations	ID: 14045 Revision: 3
Authority: Technical Leader	Page: 21 of 50
Original maintained by Quality Programs; copies are uncontrolled.	

**A.6.** This section provides photographs of alarms **with ESD**, to assist the examiner in properly identifying the presence of ESD on horn chamber surfaces during examinations.

**A.6.1. Alarm Type: Internal Horn Chamber**

A.6.1.1. External and Vertical Faces (Figure 16-Figure 17)

A.6.1.1.1. ESD on the external face of the horn chamber is defined as differential soot deposition, localized circumferentially around the horn opening.

A.6.1.1.2. ESD on the vertical face is defined as differential soot deposition localized to the sheer face connecting the external and internal faces.

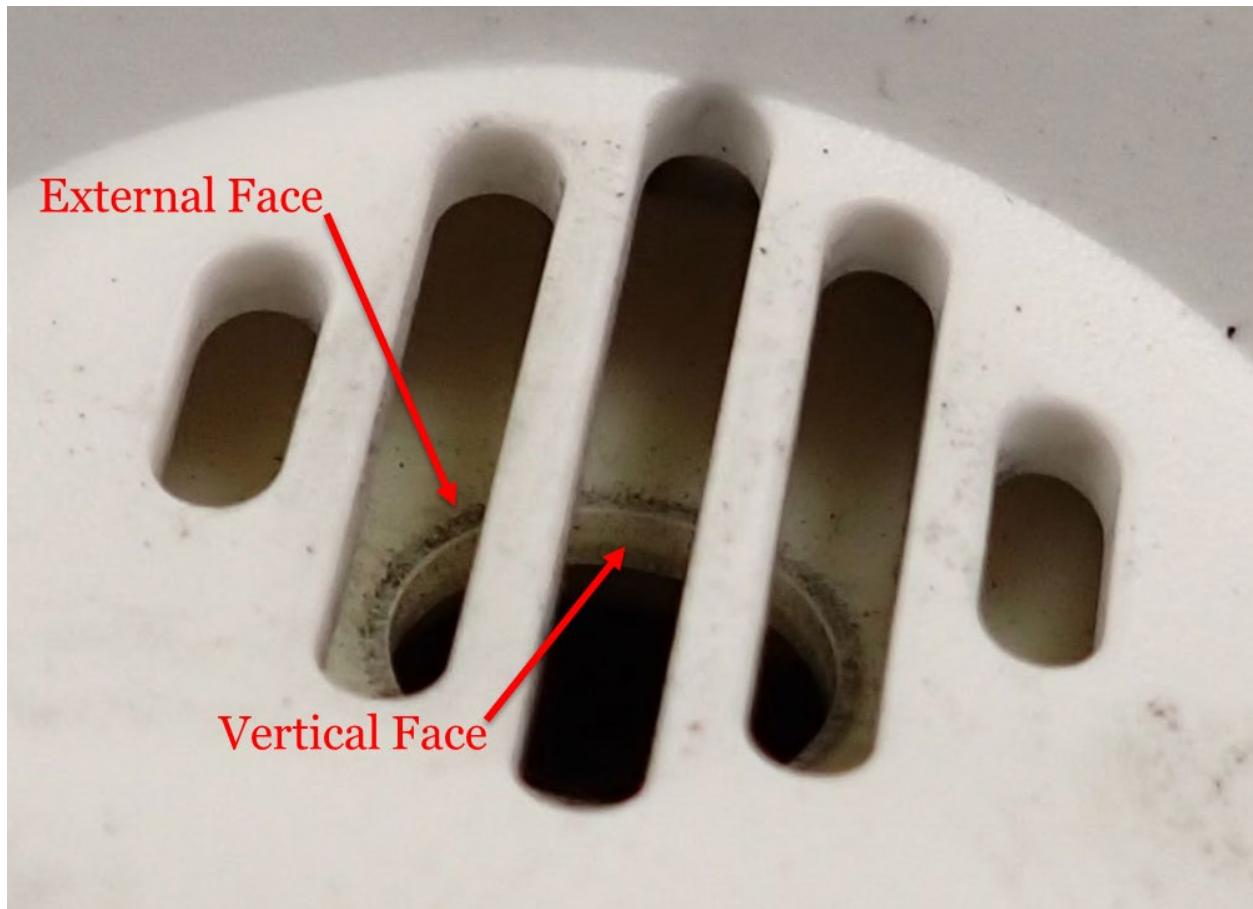

Figure 16. Example of a smoke alarm with ESD on the external and vertical faces of the horn chamber, observable without removing the alarm cover. Note the differential soot deposition localized circumferentially around the horn chamber opening.

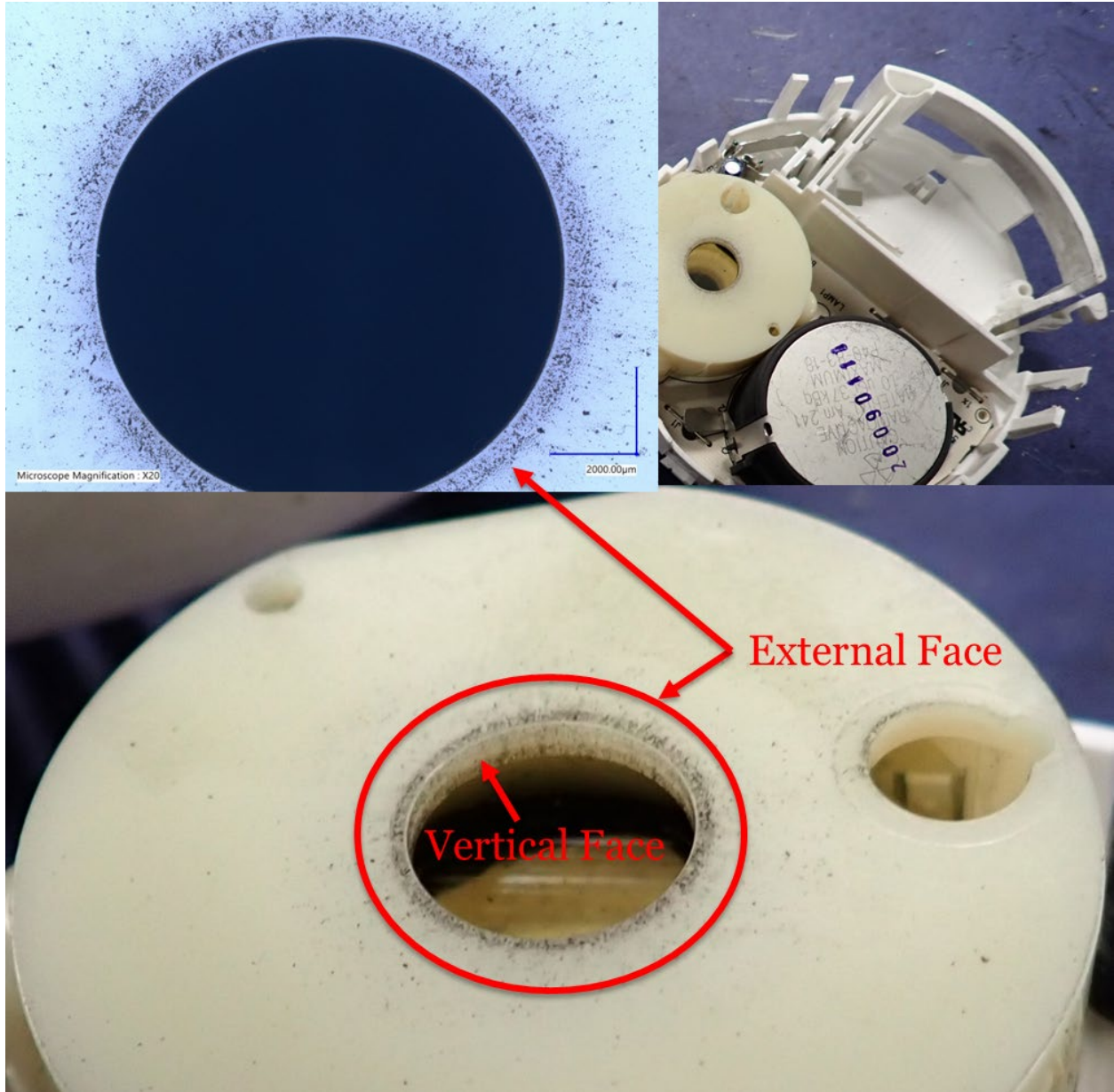

Figure 17. Example of a smoke alarm with ESD on the external and vertical faces of the horn chamber (alarm cover removed). Note the differential soot deposition localized circumferentially around the horn chamber opening on the external and vertical faces.

A.6.1.2. Horn Chamber, Horn Chamber Internal and Vertical Faces (Figure 18).

- ESD within the horn chamber is defined as differential (more) soot deposition within the horn chamber volume relative to adjacent surfaces of the alarm (as observed in Figure 18)
- ESD on the internal face of the horn chamber is defined as differential soot deposition, localized circumferentially around the horn opening.
- ESD on the vertical face is defined as differential soot deposition localized to the sheer face connecting the external and internal faces.

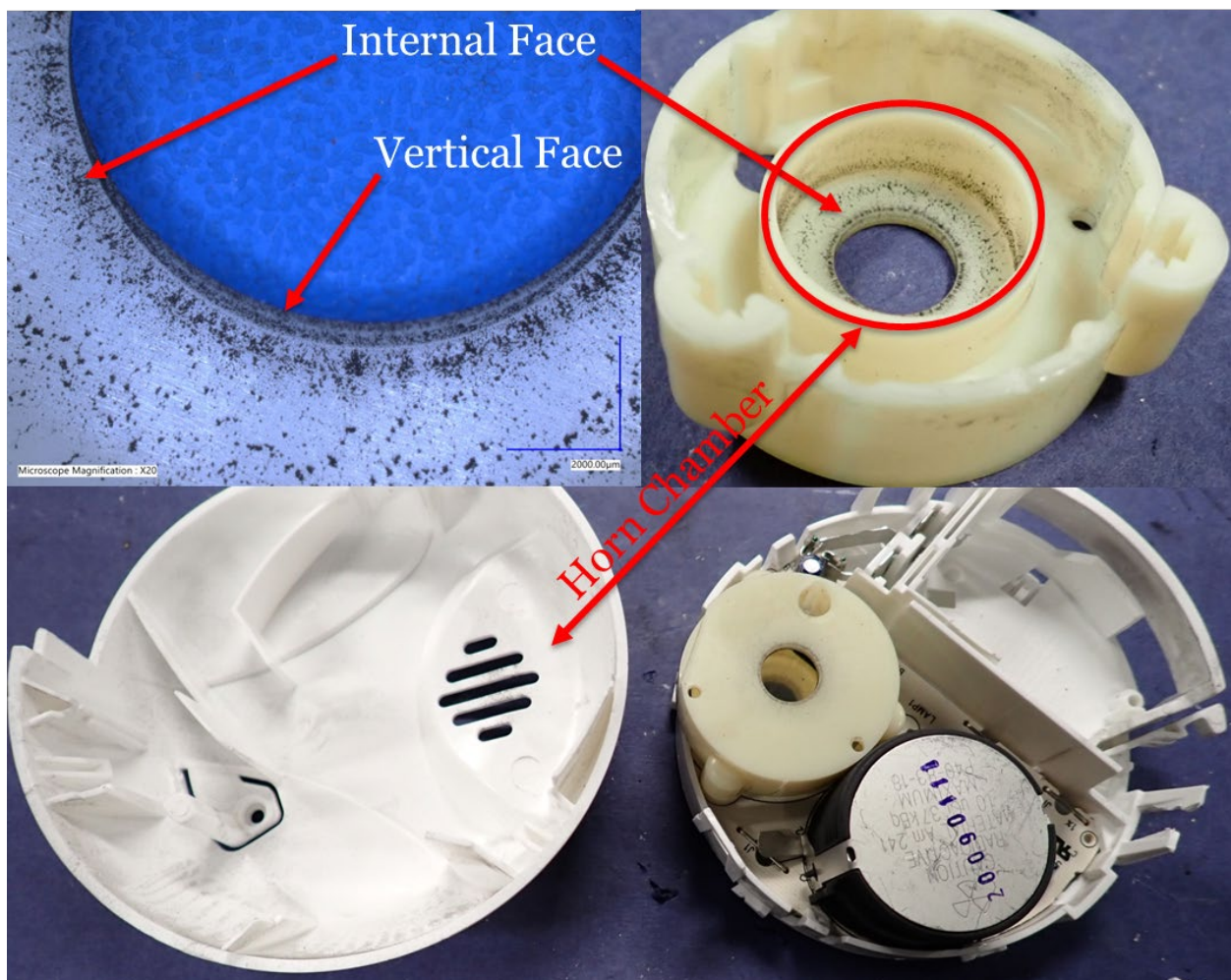

Figure 18. Example of a smoke alarm horn chamber with ESD observed within the horn chamber, on the internal and vertical faces. Note the comparison between the horn chamber and adjacent alarm surfaces.



### A.6.2. Alarm Type: External Horn Chamber Integrated into Alarm Cover

#### A.6.2.1. External and vertical faces of horn chamber

- ESD on the external face of the horn chamber is defined as differential soot deposition, localized near the horn openings.
- ESD on the vertical face is defined as differential soot deposition localized to the sheer face connecting the external and internal faces.

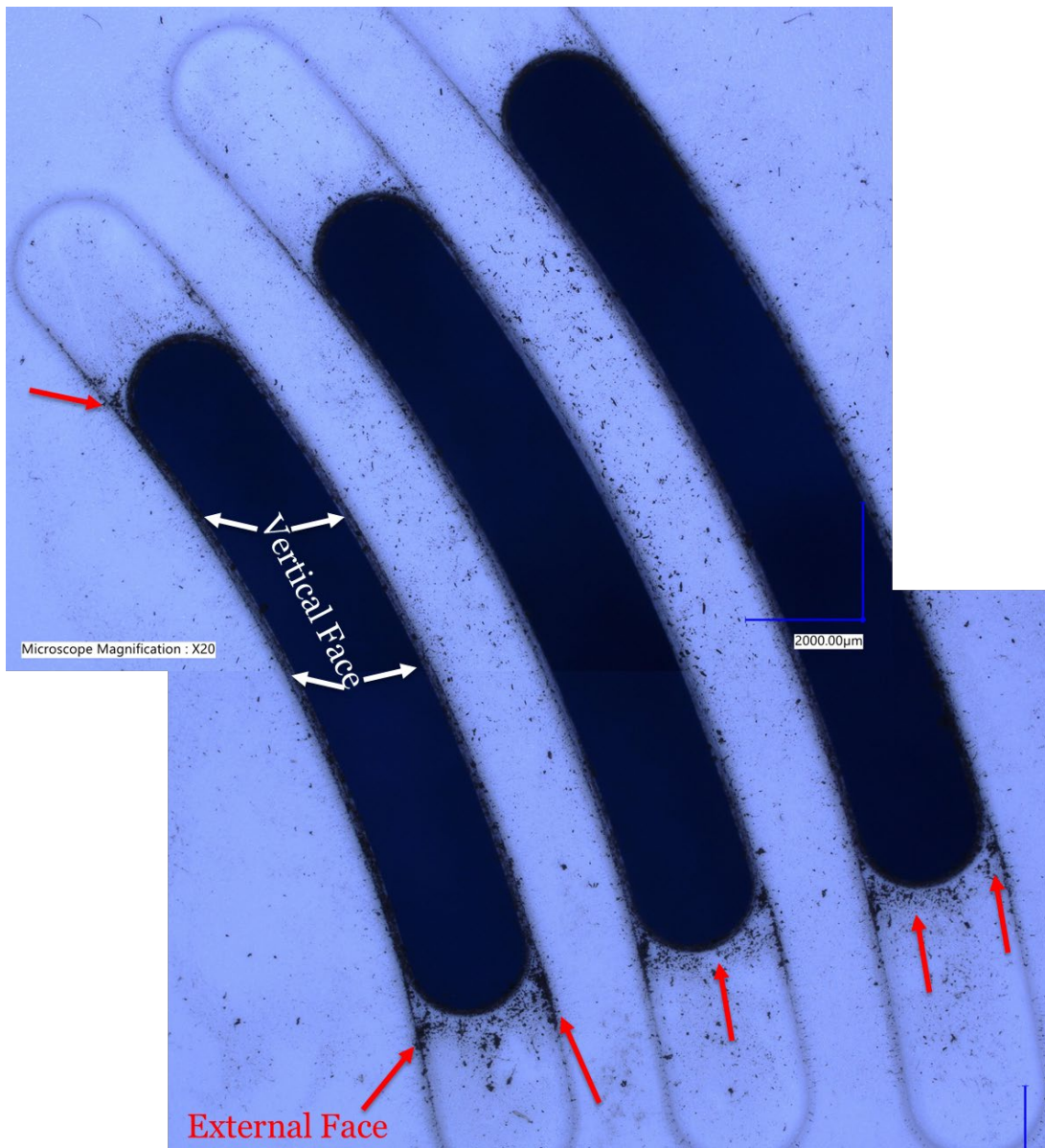

Figure 19. Example of a smoke alarm with ESD observed on the external and vertical faces of the horn chamber.



A.6.2.2. Horn chamber internal surfaces

- ESD within the horn chamber is defined as differential (more) soot deposition within the horn chamber volume relative to adjacent surfaces of the alarm (as observed in Figure 20).
- ESD on the internal face is defined as differential soot deposition, localized circumferentially around the horn opening (as observed in Figure 21)

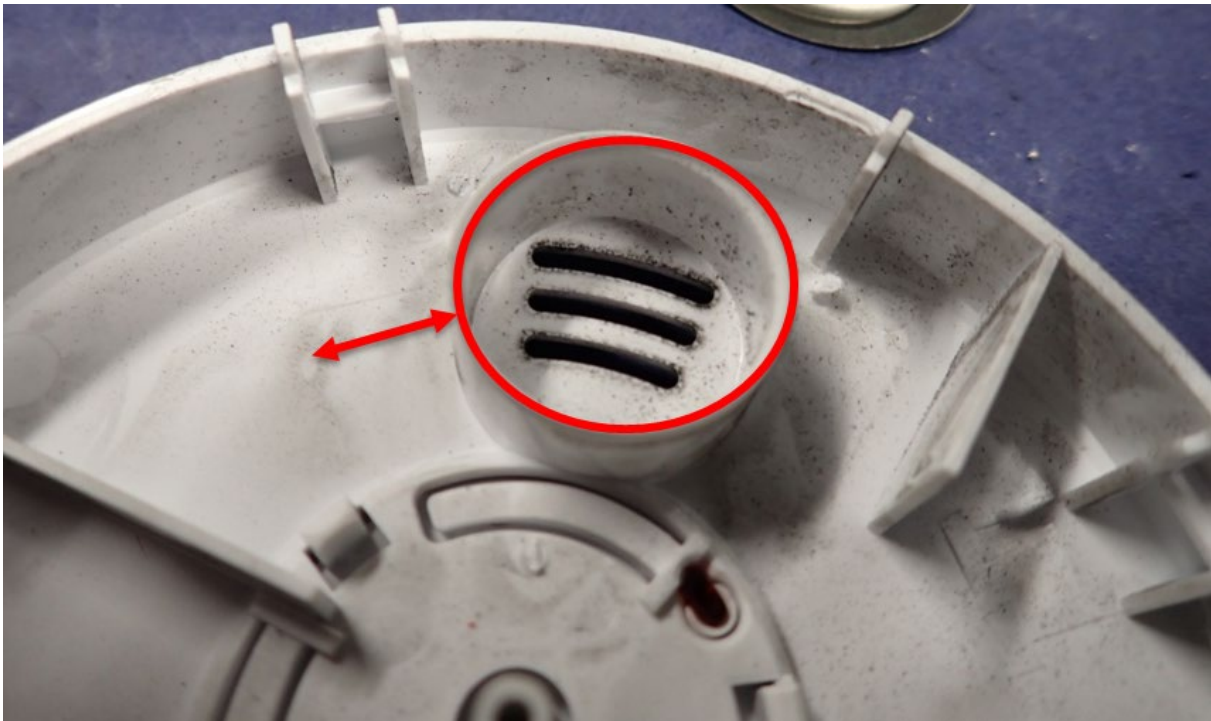

Figure 20. Example of a smoke alarm with ESD observed within the horn chamber volume. Note the relative soot density within the chamber relative to outside the chamber.



ATF-LS-FRL Engineering - Smoke Alarm Evidence Examinations	ID: 14045 Revision: 3
Authority: Technical Leader	Page: 26 of 50
Original maintained by Quality Programs; copies are uncontrolled.	

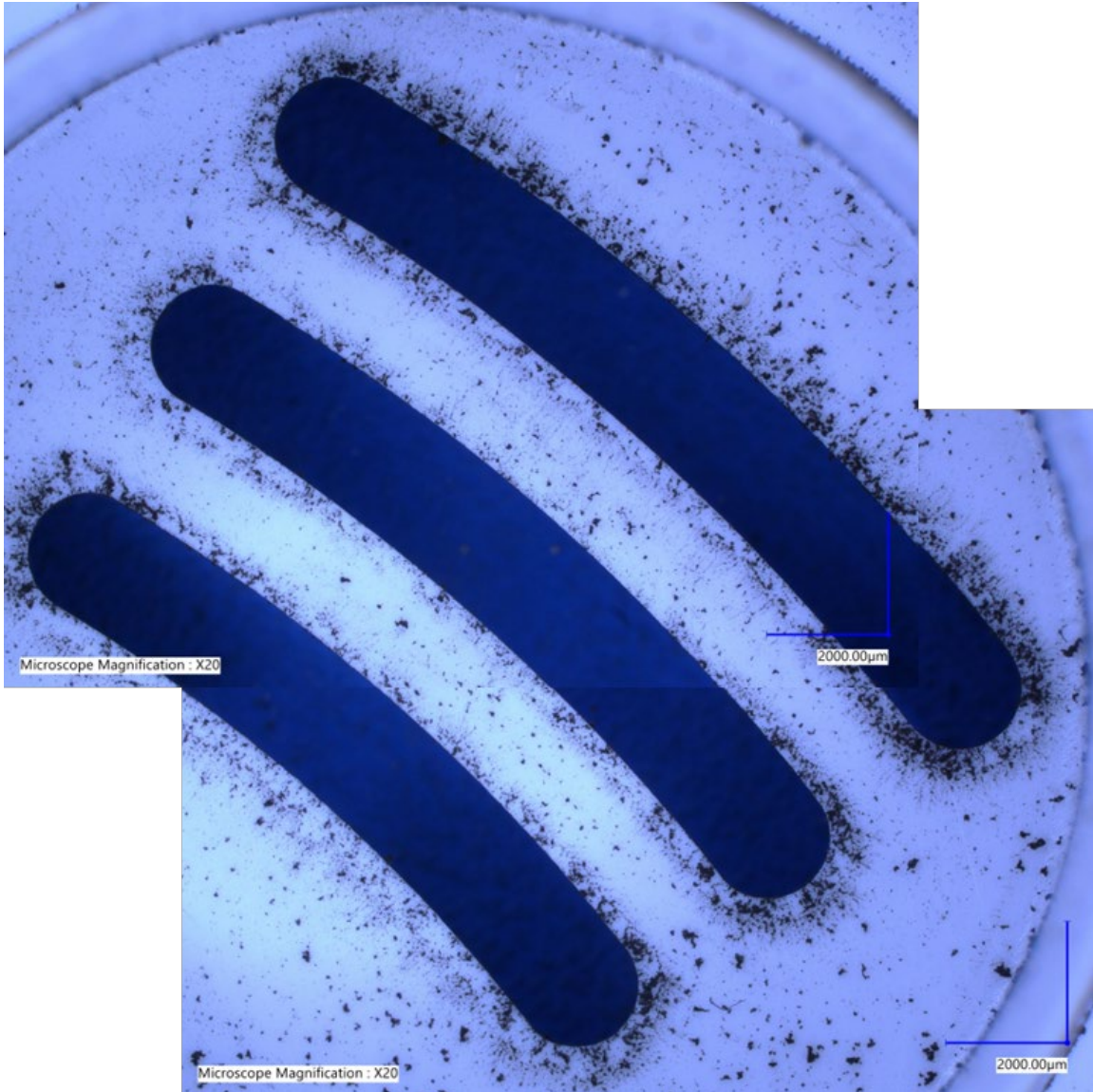

Figure 21. Example of a smoke alarm with ESD observed on the internal face of the horn chamber. Note the differential soot deposits localized near the horn openings.



### A.6.3. Alarm Type: Horn Chamber Intimate with Alarm Cover

- A.6.3.1. For this type of alarm, what is considered external and internal surfaces may be subjective.
- A.6.3.2. Examining the horn chamber for ESD may be particularly difficult given the dark coloring of the horn chamber for these types of alarms, leading to a lack of contrast on which to observe possible ESD.
- A.6.3.3. For best practice, document all surfaces, from the alarm cover exterior opening (Figure 23-Figure 25) through the horn chamber interior (Figure 26 - Figure 27).
  - For best results, use microscopic imagery at various angles and oblique lighting to determine the presence of ESD in low contrast situations.
- A.6.3.4. Per Phelan, Et. Al. (2.3.1), ESD forms from the interior of the horn chamber outwards. Therefore, if ESD is observed on the outermost surfaces, ESD on the innermost surfaces is likely as well.
- A.6.3.5. Alarm Example 1 (Figure 22-Figure 27)

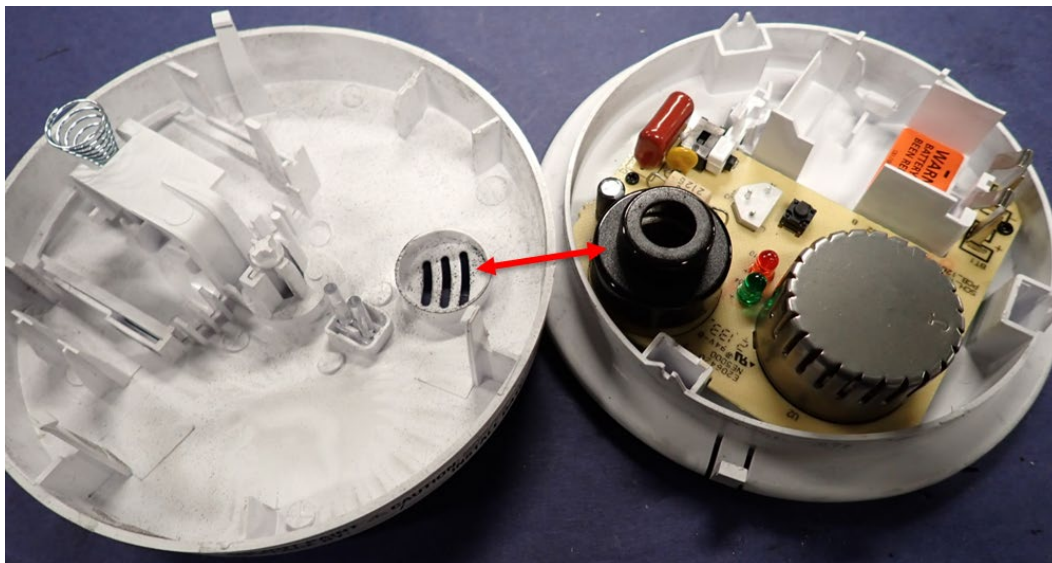

Figure 22. Example of a smoke alarm with horn chamber intimate with alarm cover.

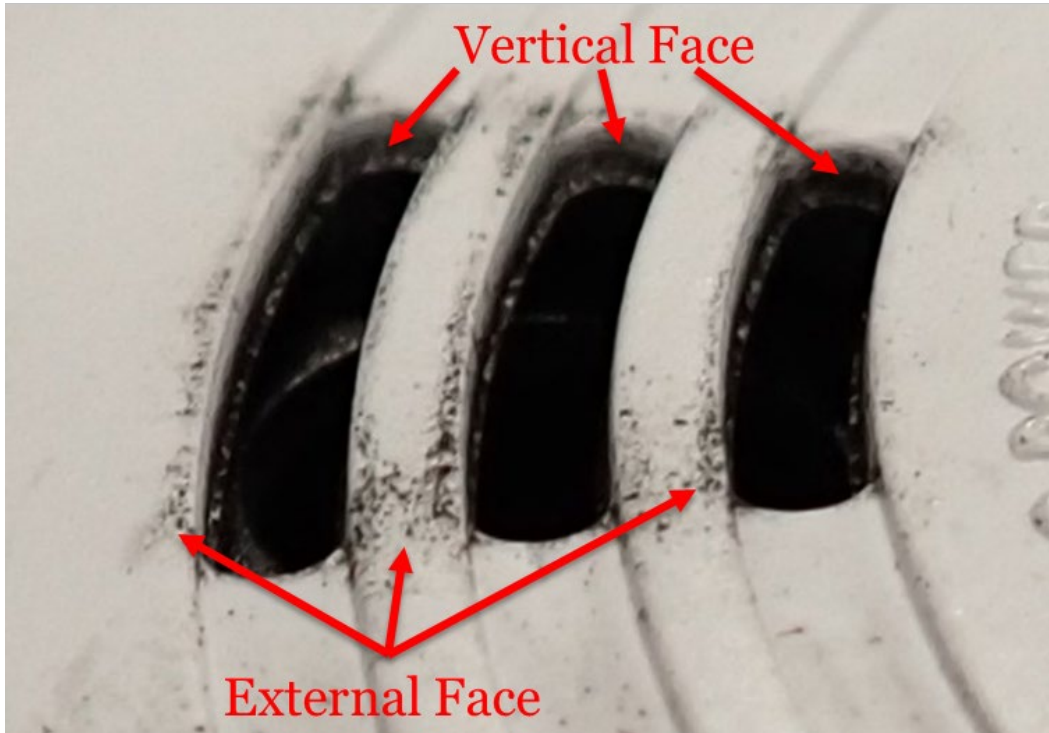

Figure 23. Example of a smoke alarm with ESD on the external and vertical faces of the alarm cover openings. Note the differential soot deposition, localized circumferentially around the openings in the alarm cover.



Figure 24. ESD observed within the alarm cover inset for the horn chamber. Note the differential soot deposition (more) with relative to that observed on adjacent surfaces.

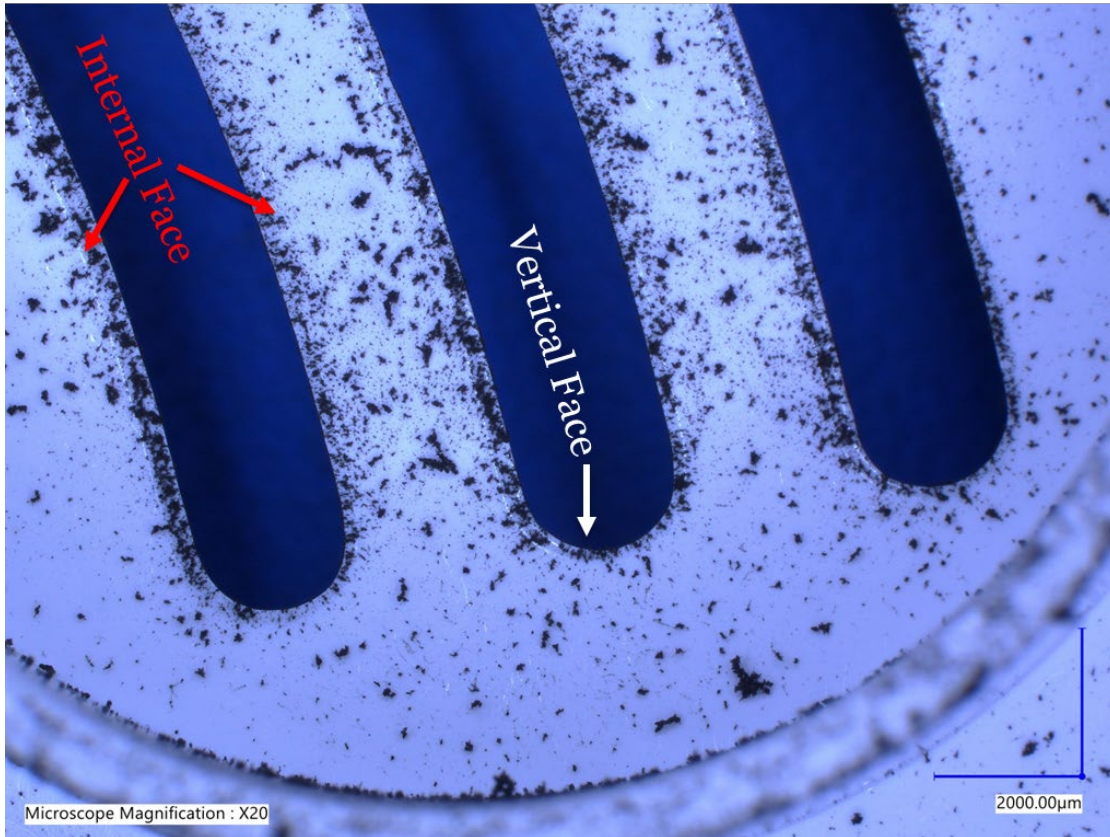

Figure 25. ESD observed on the internal and vertical faces of the alarm cover inset for the horn chamber.

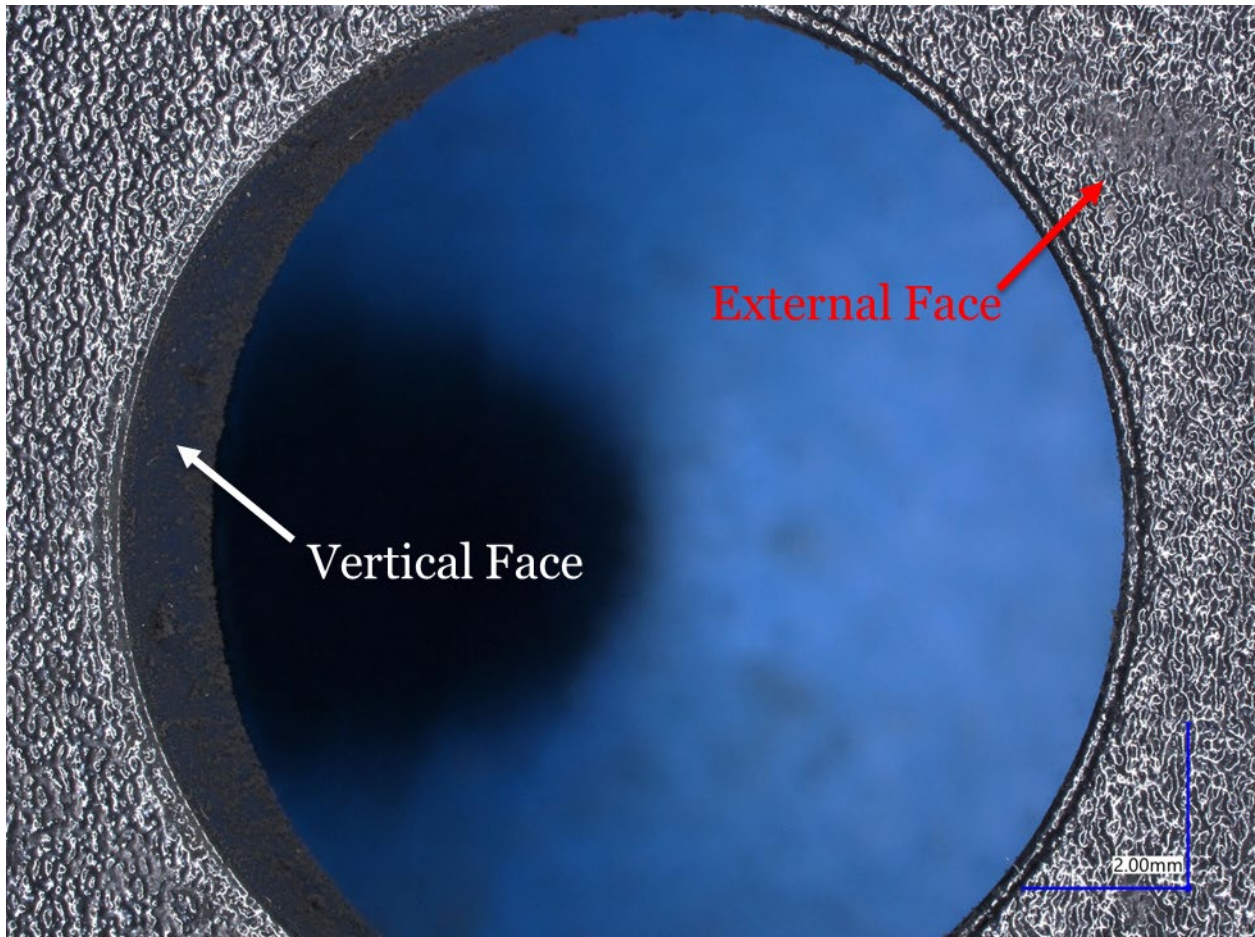

Figure 26. Horn chamber external and vertical faces. ESD observed on the vertical face only.

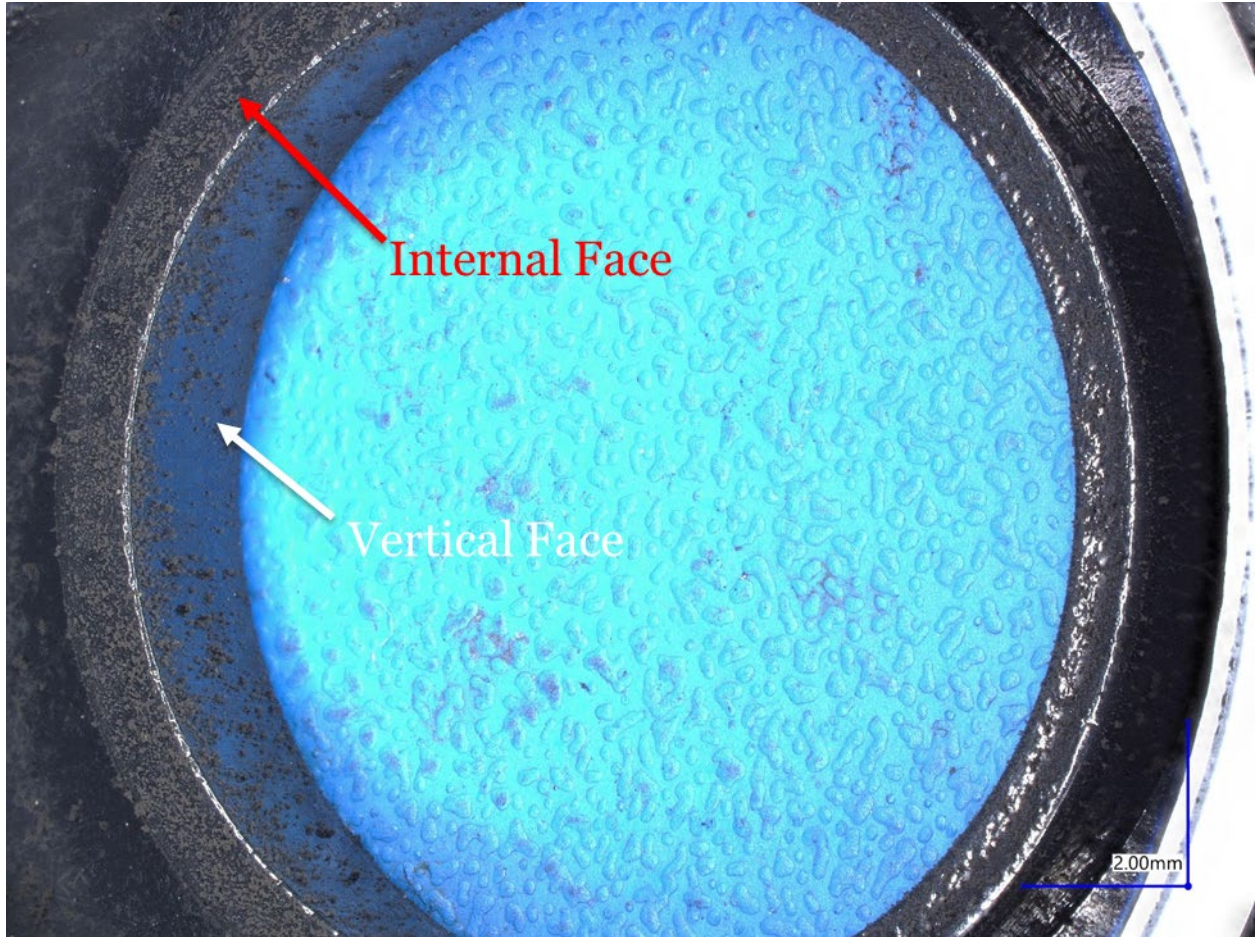

Figure 27. Horn chamber internal and vertical faces. ESD observed on internal and vertical faces.



ATF-LS-FRL Engineering - Smoke Alarm Evidence Examinations	ID: 14045 Revision: 3
Authority: Technical Leader	Page: 32 of 50
Original maintained by Quality Programs; copies are uncontrolled.	

A.6.3.6. Alarm Example 2 (Figure 28-Figure 33)



Figure 28. Example of alarm with horn chamber intimate with alarm cover.



Figure 29. Example of a smoke alarm with ESD on the external and vertical faces of the alarm cover openings. Note the differential soot deposition, localized circumferentially around the openings in the alarm cover.

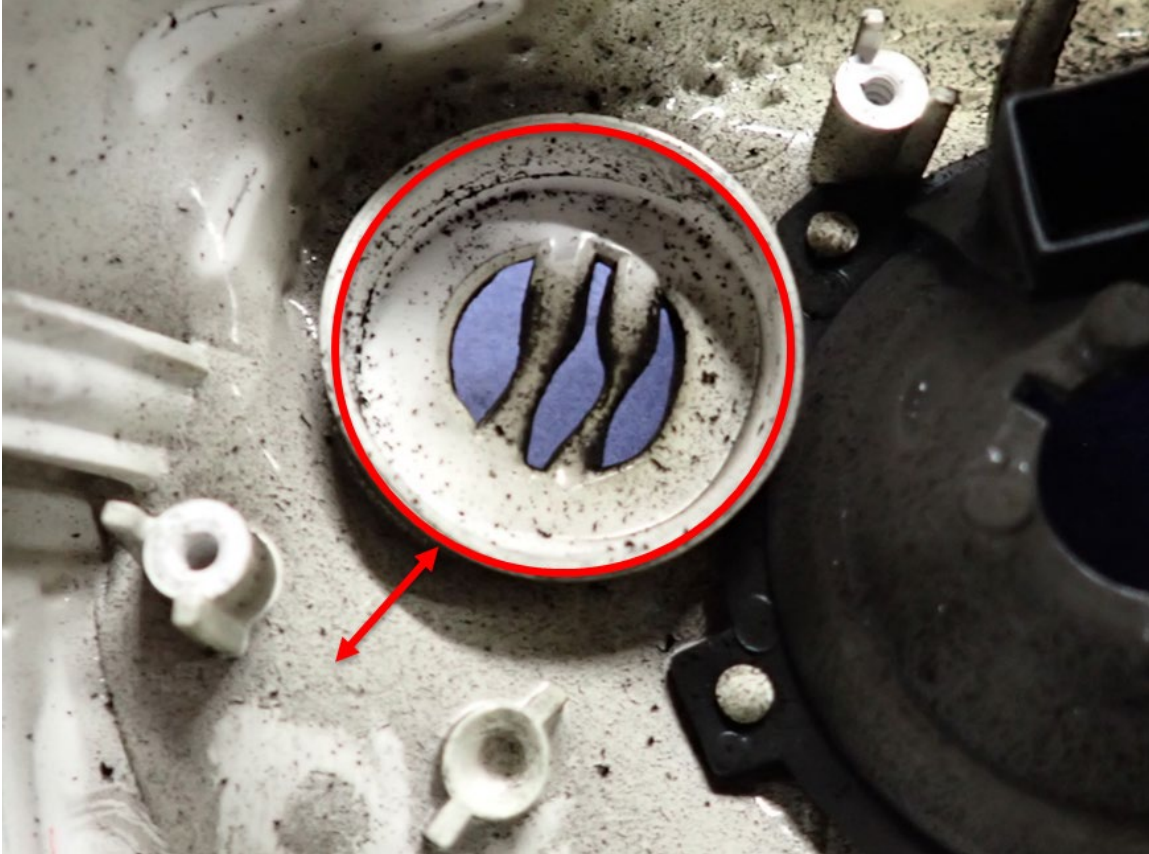

Figure 30. ESD observed within the alarm cover inset for the horn chamber. Note the differential soot deposition (more) relative to that observed on adjacent surfaces.

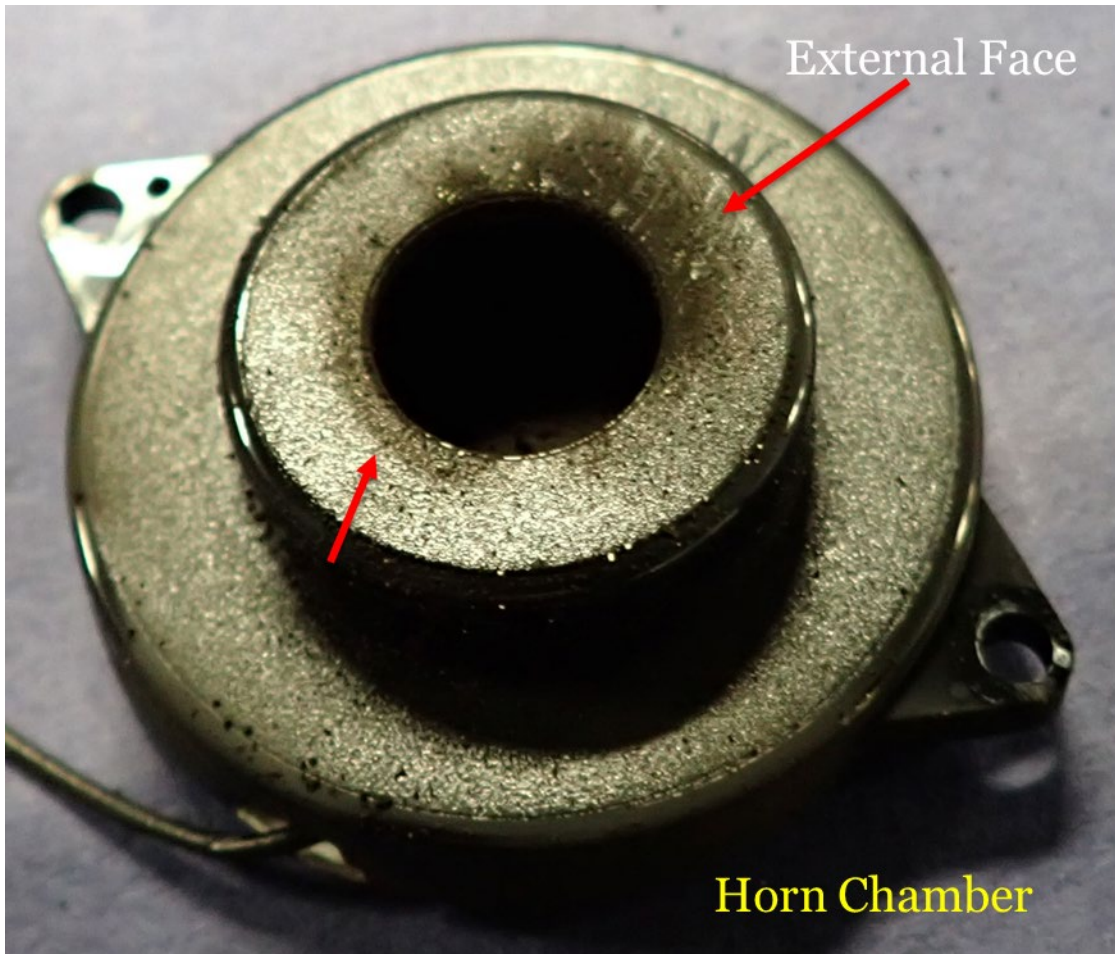

Figure 31. ESD observed on the external face of the horn chamber.

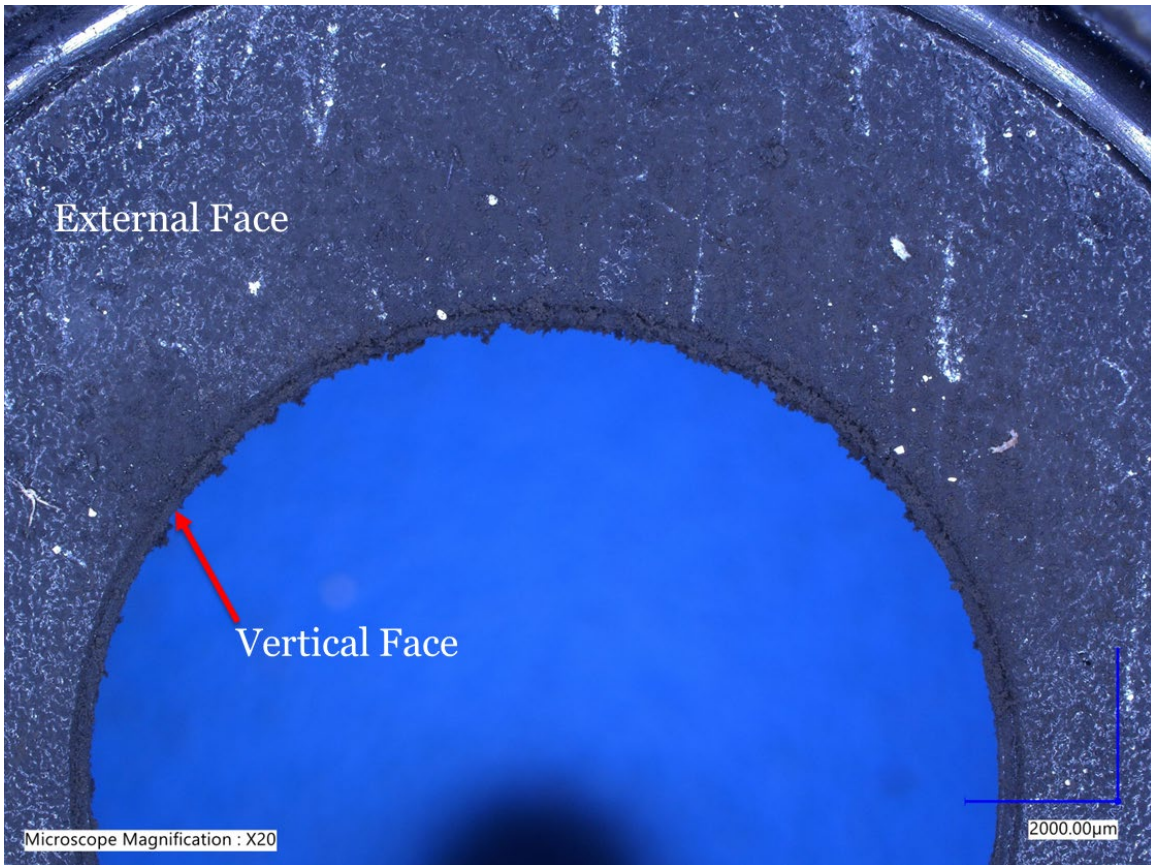

Figure 32. ESD observed on the external and vertical faces of the horn chamber.



ATF-LS-FRL Engineering - Smoke Alarm Evidence Examinations	ID: 14045 Revision: 3
Authority: Technical Leader	Page: 37 of 50
Original maintained by Quality Programs; copies are uncontrolled.	

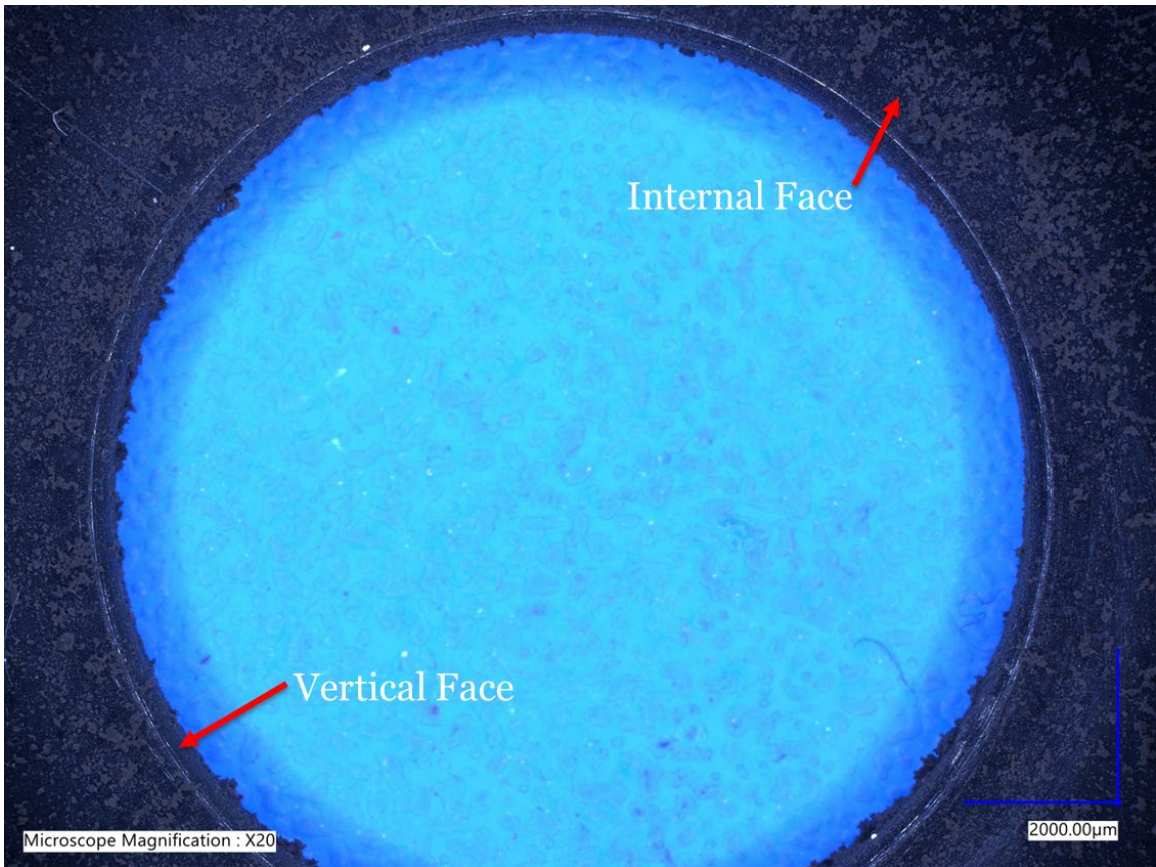

Figure 33. ESD observed on the internal and vertical faces of the horn chamber.



ATF-LS-FRL Engineering - Smoke Alarm Evidence Examinations	ID: 14045 Revision: 3
Authority: Technical Leader	Page: 38 of 50
Original maintained by Quality Programs; copies are uncontrolled.	

A.7. This section provides photographs of smoke alarm horn chamber surfaces with Enhanced Tarry Depositions (ETD), consistent with sounding alarms in the presence of products of smoldering combustion.

A.7.1. Alarm Example 1 (Figure 34-Figure 36)

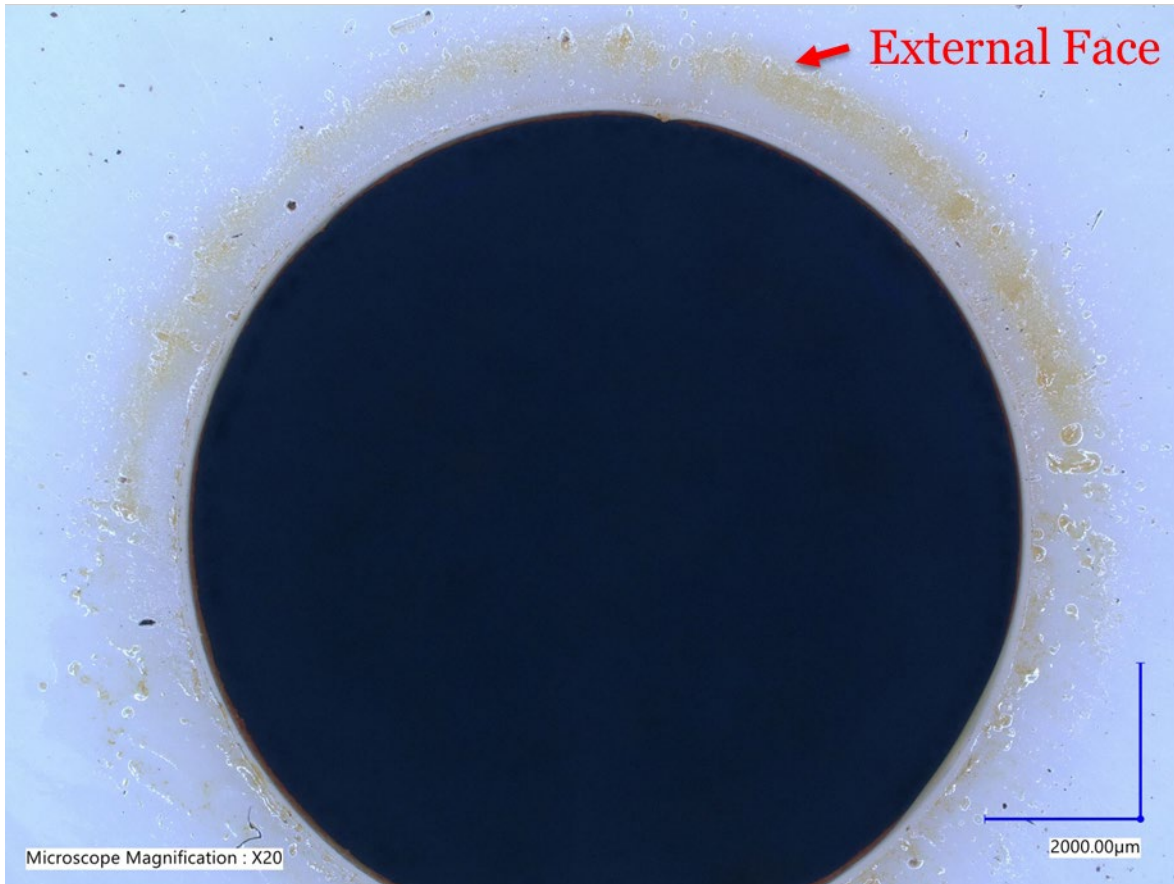

Figure 34. Example of a smoke alarm with ETD on the external face of the horn chamber.

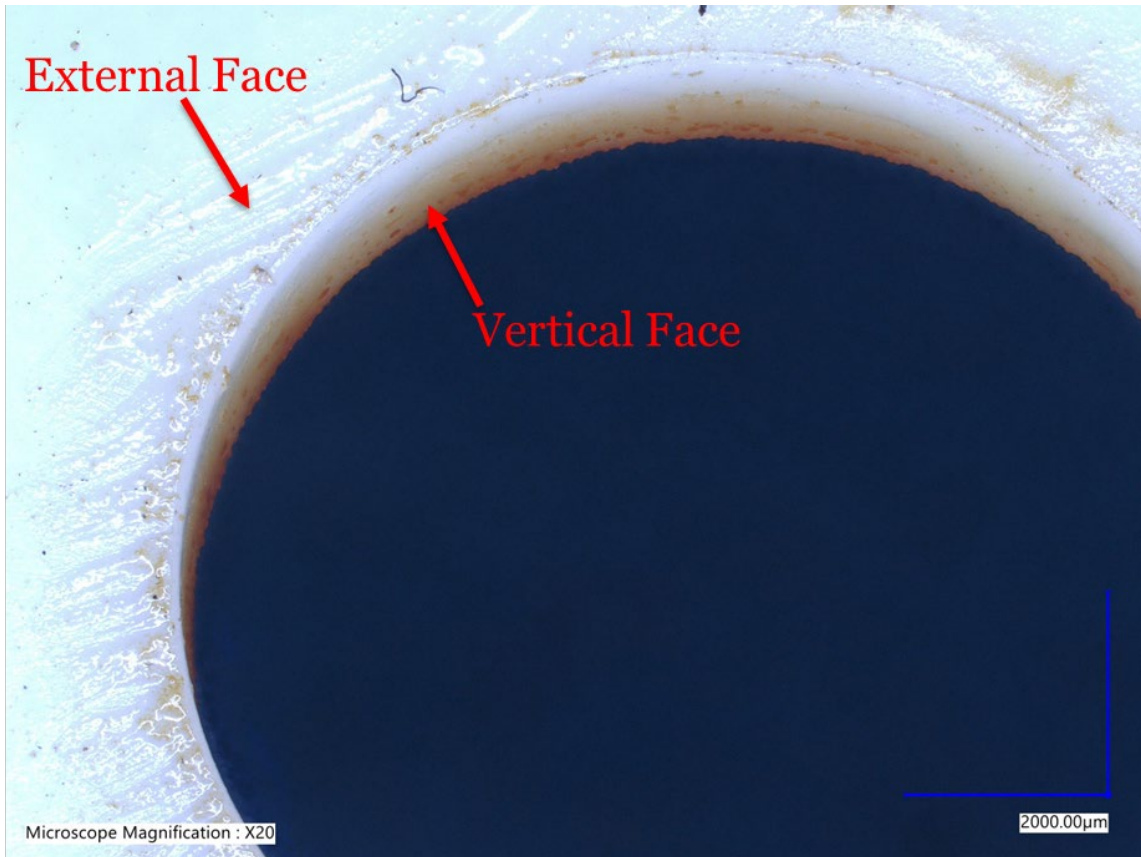

Figure 35. Example of a smoke alarm with ETD on the external and vertical faces of the horn chamber.

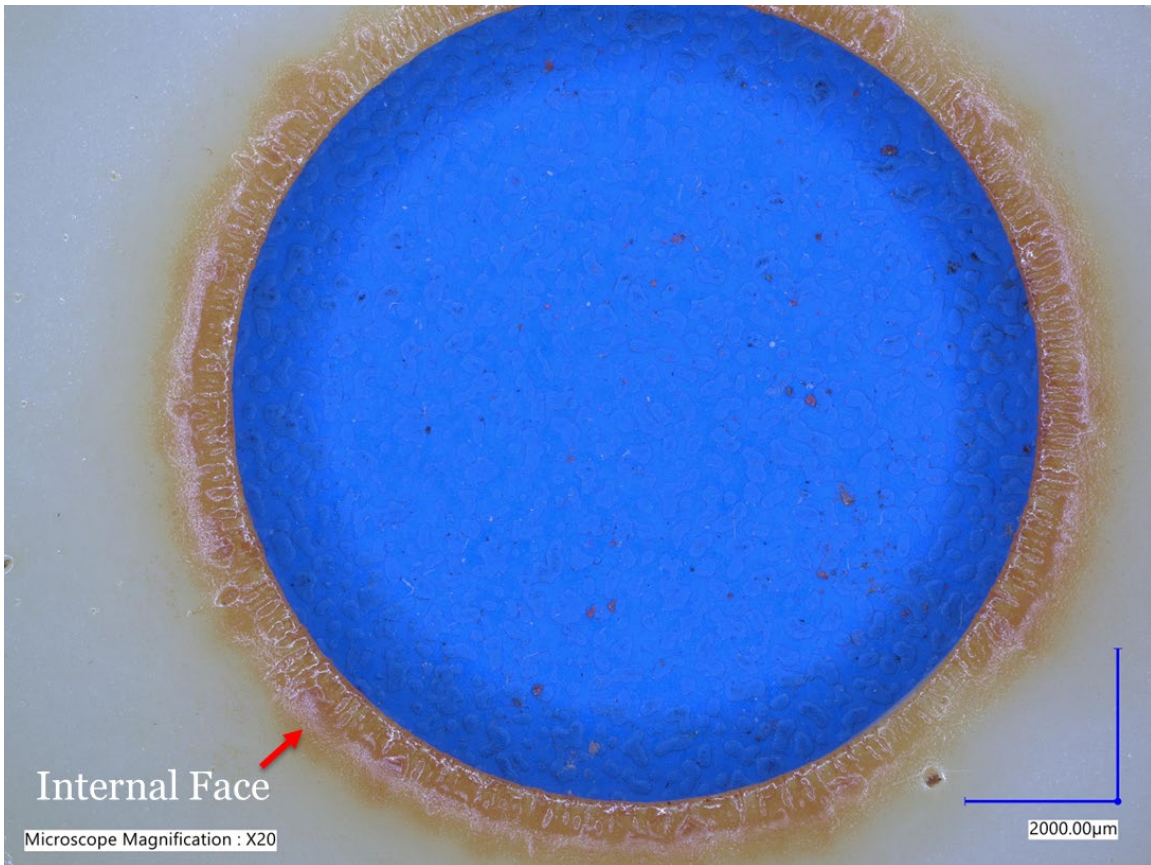

Figure 36. Example of a smoke alarm with ETD on the internal face of the horn chamber.



ATF-LS-FRL Engineering - Smoke Alarm Evidence Examinations	ID: 14045 Revision: 3
Authority: Technical Leader	Page: 41 of 50
Original maintained by Quality Programs; copies are uncontrolled.	

A.7.2. Alarm Example 2 (Figure 37-Figure 39)



Figure 37. Example of a smoke alarm with ETD on the external face of the horn chamber.

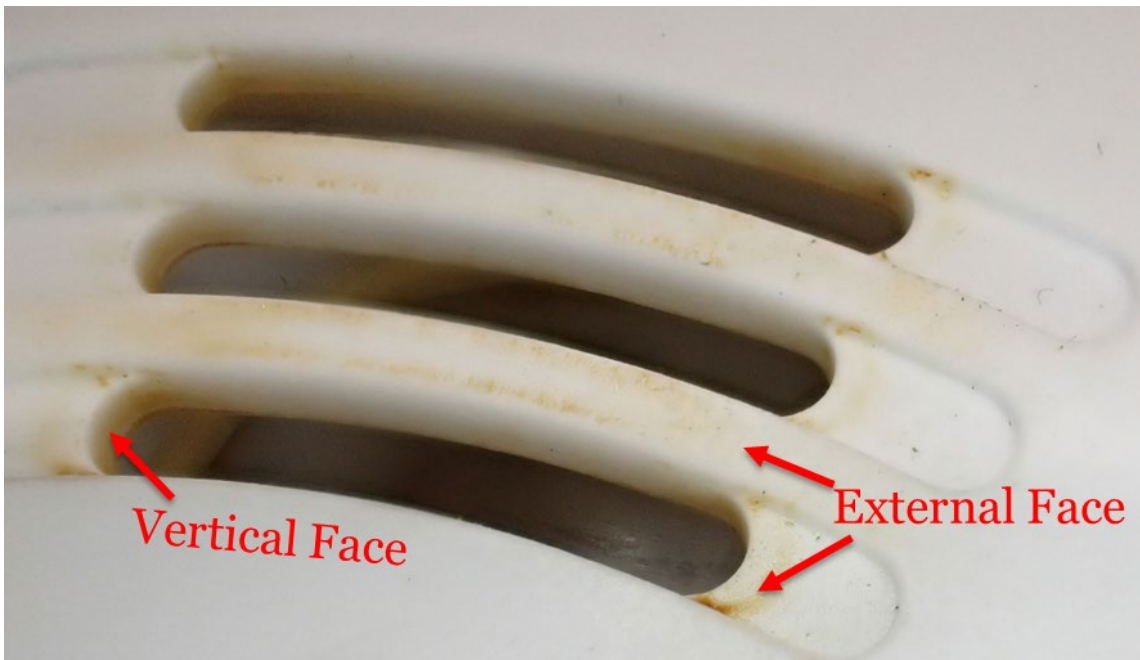

Figure 38. Example of a smoke alarm with ETD on the external and vertical faces of the horn chamber.



Figure 39. Example of a smoke alarm with ETD on the internal face of the horn chamber.



ATF-LS-FRL Engineering - Smoke Alarm Evidence Examinations	ID: 14045 Revision: 3
Authority: Technical Leader	Page: 43 of 50
Original maintained by Quality Programs; copies are uncontrolled.	

**A.8.** This section provides photographs of alarms without ESD, to assist the examiner in properly identifying horn chamber surfaces, devoid of ESD, during examinations.

A.8.1. The following images provide examples of smoke alarms, exposed to products of combustion, without ESD on the horn chamber surfaces.

A.8.1.1. Alarm example 1 (Figure 40-Figure 42)



Figure 40. Example of an exposed smoke alarm without ESD on the external face of the horn chamber. Note the relatively uniform distribution of soot on all exposed surfaces.



ATF-LS-FRL Engineering - Smoke Alarm Evidence Examinations	ID: 14045 Revision: 3
Authority: Technical Leader	Page: 44 of 50
Original maintained by Quality Programs; copies are uncontrolled.	

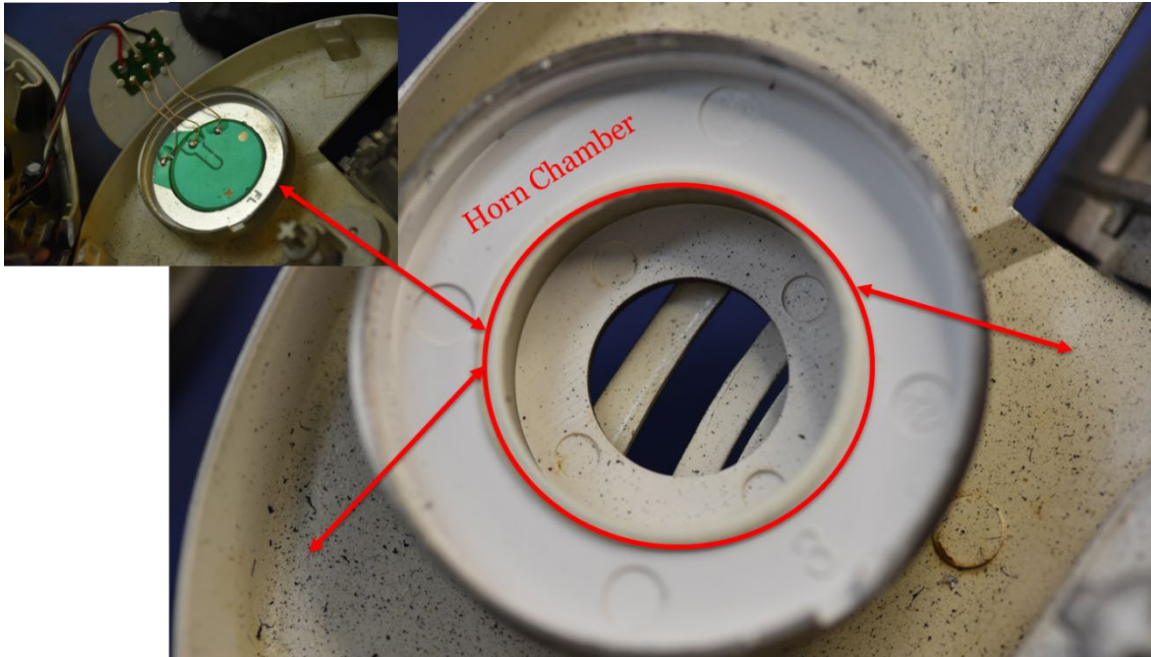

Figure 41. Example of an exposed smoke alarm horn chamber without ESD. Note the relatively reduced soot deposition within the horn chamber as compared to outside the horn chamber.



ATF-LS-FRL Engineering - Smoke Alarm Evidence Examinations	ID: 14045 Revision: 3
Authority: Technical Leader	Page: 45 of 50
Original maintained by Quality Programs; copies are uncontrolled.	

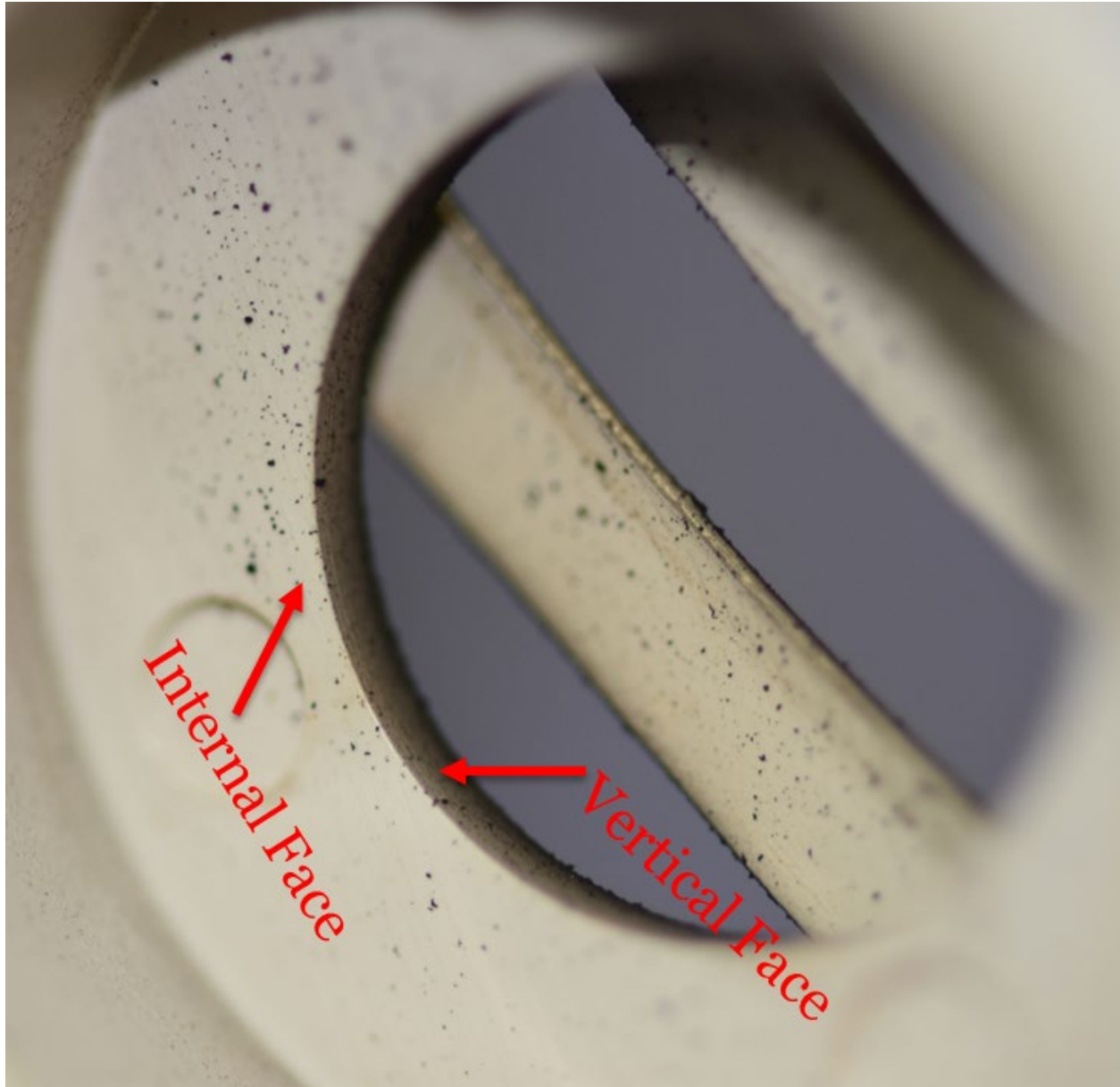

Figure 42. Example of an exposed smoke alarm horn chamber internal and vertical faces. Note the relatively uniform distribution of soot deposits on all surfaces and specifically the lack of the circumferential deposits around the opening.



A.8.1.2. Alarm example 2 (Figure 43-Figure 47)



Figure 43. Example of an exposed smoke alarm without ESD on the external face of the horn chamber.



Figure 44. Example of an exposed smoke alarm without ESD on the external face of the horn chamber.



Figure 45. Example of an exposed smoke alarm without ESD within the horn chamber

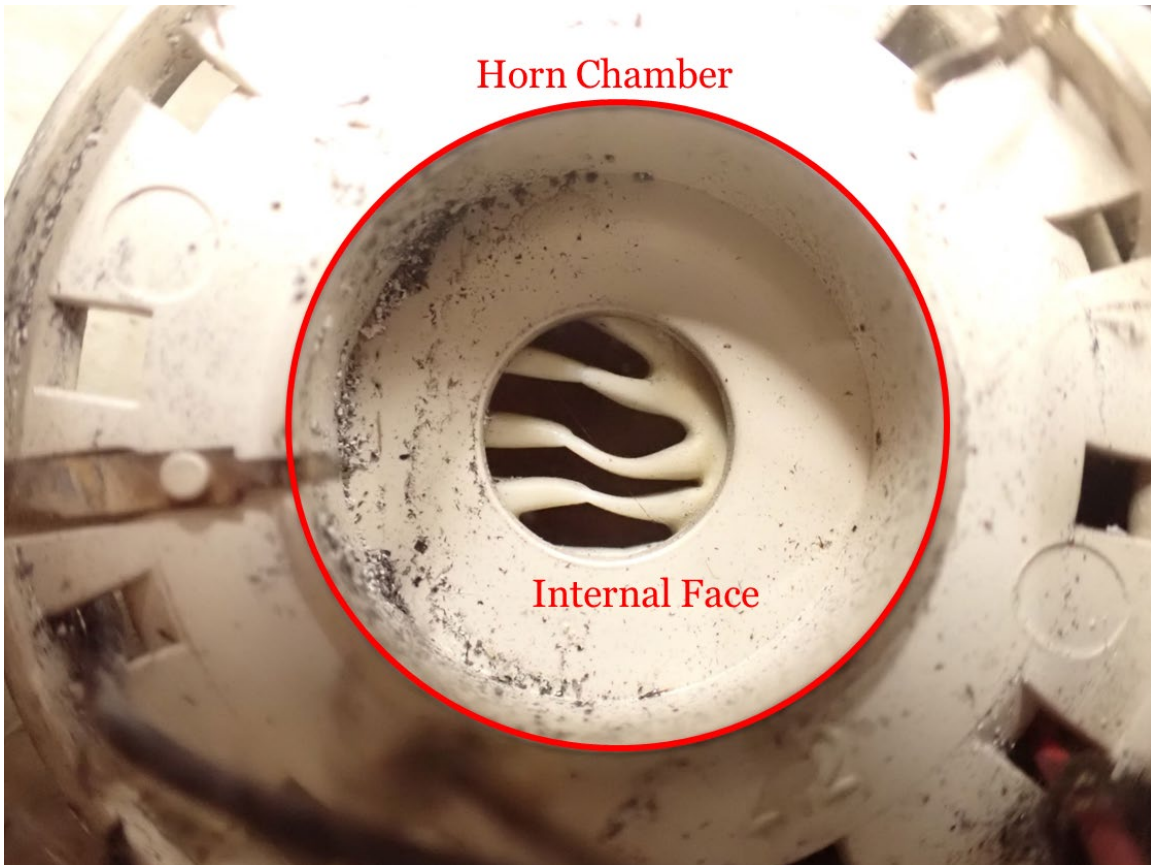

Figure 46. Example of an exposed smoke alarm without ESD within the horn chamber. Note the non-uniform accumulation of debris on the left-side of the horn chamber (as viewed in photo); this is likely a gravity related effect on a wall-mounted alarm.



ATF-LS-FRL Engineering - Smoke Alarm Evidence Examinations	ID: 14045 Revision: 3
Authority: Technical Leader	Page: 50 of 50
Original maintained by Quality Programs; copies are uncontrolled.	

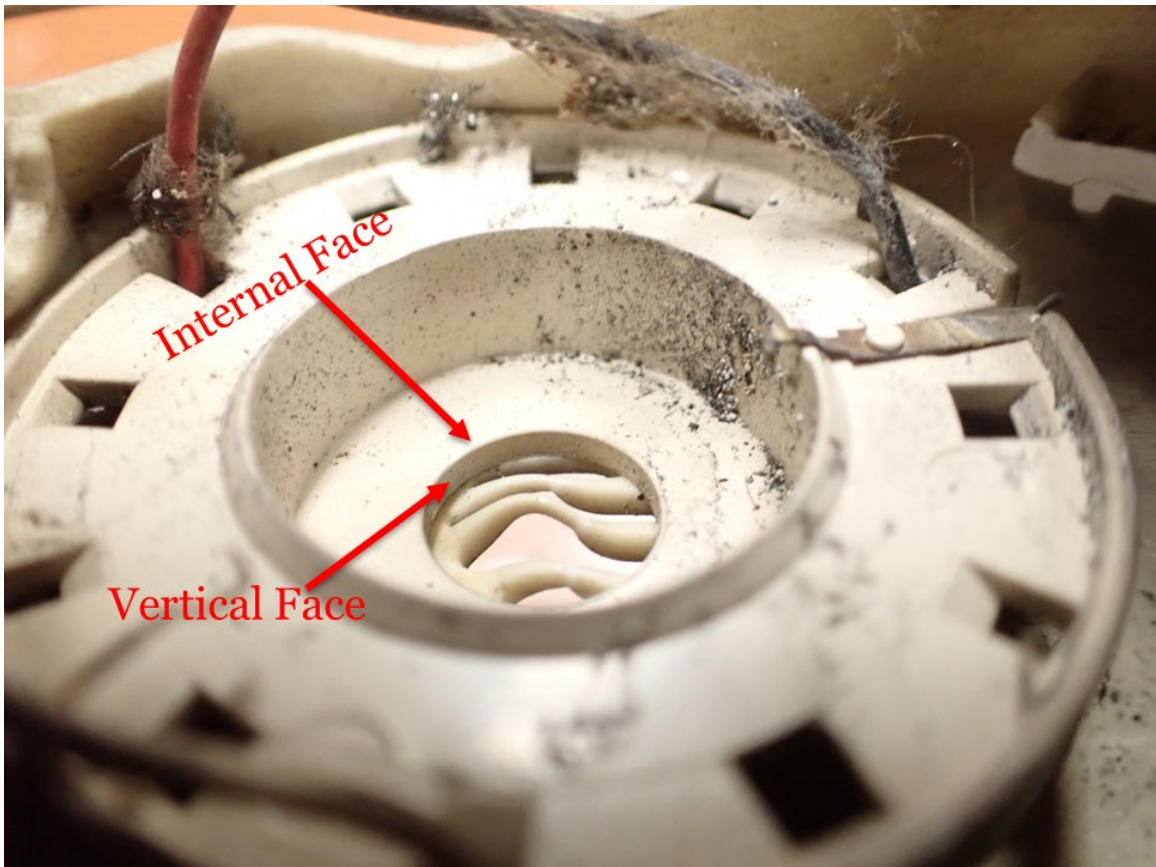

Figure 47. Example of an exposed smoke alarm without ESD on the horn chamber internal or vertical faces.



ATF-LS-FRL Engineering Activities	ID: 7701
	Revision: 2
Authority: Technical Leader	Page: 1 of 7
Original maintained by Quality Programs; copies are uncontrolled.	

1. Title: Procedure for Engineering Activities

2. Scope:

2.1. When the Fire Research Laboratory (FRL) performs work for a client a project is opened in the Laboratory Project Management System. There are four types of FRL Projects: Scene Examination, Evidence Examination, Laboratory, and Engineering Analysis. Each project consists of one or more “Engineering Activities” as defined in this document.

2.2. This procedure defines the process used to accept, decline and perform Engineering Activities at the Fire Research Laboratory (FRL). Engineering Activities include Documentation, Physical Examinations, and Analysis.

2.3. This procedure applies to engineering activities performed at the laboratory and off-site.

3. Summary

The overall procedure for engineering activities is shown the flow chart in Figure 1. The left-hand boxes start the process with client requests for three types of activities. The dashed connectors indicate when multiple projects are conducted to support an analysis activity. A detailed description of the procedure for each type of activity is provided in section 4 through section 6.

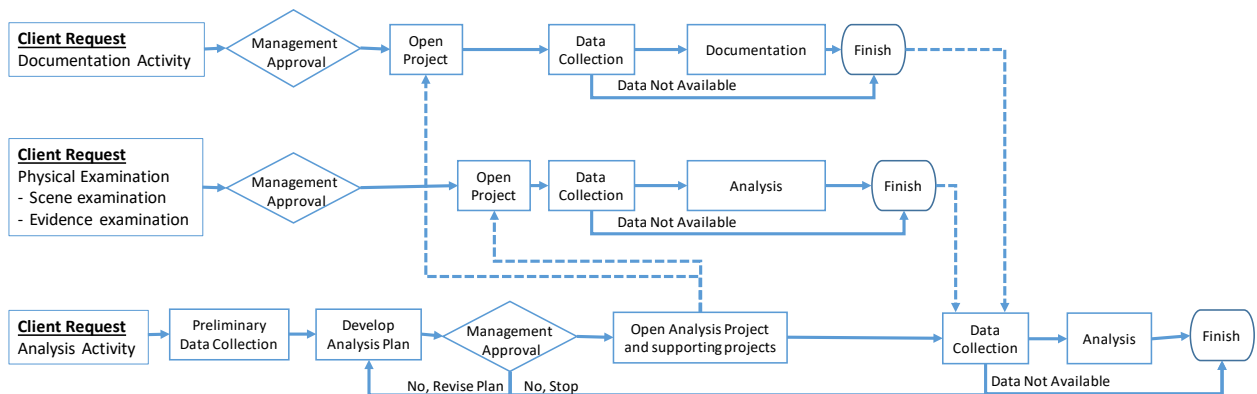

Figure 1. FRL Procedure for Engineering Activities

4. Documentation Activities:

4.1. Documentation activities consist of gathering or generating information without performing an analysis to develop an opinion about how the information relates to an investigation. Documentation activities produce either stand-alone fact reports or are recorded as part of an existing project.

4.2. Examples of Documentation Activities



ATF-LS-FRL Engineering Activities	ID: 7701 Revision: 2
Authority: Technical Leader	Page: 2 of 7
Original maintained by Quality Programs; copies are uncontrolled.	

- Conducting experiments to generate data. The result is a fact report that describes the experiments that were conducted and the measurements that were obtained.
- Developing a description of electrical or gas utilities within a structure. This could involve contacting utility companies, local building departments, reading blueprints, and tracing wiring during a scene examination.
- Developing a timeline related to events that occurred before, during and after a fire event.

#### 4.3. Procedure for Documentation Activities.

Figure 2 shows a flow chart of the process followed for Documentation activities. Each step in the process is described in the text following the figure.

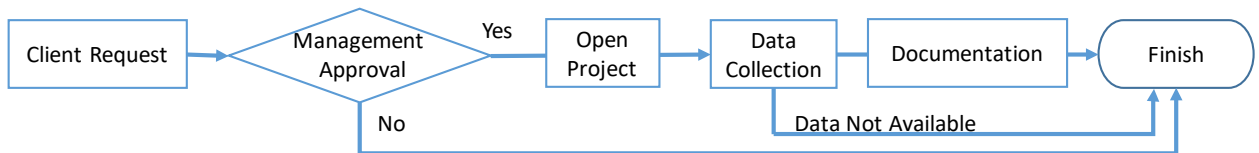

Figure 2. Flow Chart of the Process for Documentation Activities

#### 4.4. Client Request – Client requests for Documentation activities are received in one of three ways.

4.4.1. External Request – The client requests a documentation activity.

4.4.2. Internal Request – When a lead engineer for an FRL project identifies the need for a Documentation activity, the engineer verbally relays the request to the Chief of the section that will perform the documentation activity.

4.4.3. Scene Examination – While an engineer is participating in a scene examination, the client can request the engineer to perform Documentation activities as part of the scene examination.

4.5. Management Approval – Management approval is required for Documentation activities that are not part of an existing project. After the initial approval, the manager has the option to cancel a Documentation activity if required data collection information is not available, see 8.3. The form of the management approval depends on the type of client request.



ATF-LS-FRL Engineering Activities	ID: 7701
	Revision: 2
Authority: Technical Leader	Page: 3 of 7
Original maintained by Quality Programs; copies are uncontrolled.	

4.5.1. External Request – The manager indicates the approval of the request by opening a project in the Laboratory’s project management system.

4.5.2. Internal Request – The manager indicates the approval of the request by opening a project in the Laboratory’s project management system.

4.5.3. Scene Examination – There are two options for management approval for documentation activities requested during a scene examination.

4.5.3.1. If the documentation activity can be completed during the scene examination or in a reasonable amount of time after the scene examination, the activity is considered part of the scene examination project and no further management approval is required.

4.5.3.2. If the documentation activity requires an extended amount of time after the scene examination, the manager will decide whether the documentation activity is included in the scene examination project or if the client must submit an external request for the Documentation activity.

4.6. Data collection – Engineers conduct data collection activities to develop in the information that is needed to develop the documentation. Data collection is described in section 7.

4.7. Finish – The activities for the project will be recorded, reviewed and documented as defined in section 8.

## 5. Physical Examination Activities:

5.1. Physical examination activities consist of the evaluation of materials, products, systems, or other items leading to an opinion about how it related to the investigation. Physical examination projects produce laboratory reports with conclusions and opinions.

### 5.2. Examples of Physical Examination projects:

- The inspection of fire damaged electrical devices using visual, microscopic, or X-Ray techniques. The result of the examination will be an opinion about whether the device could have been a potential ignition source for the fire.
- The visual examination of a smoke alarm to evaluate the acoustic agglomeration of soot. The result of the examination will be an opinion about whether the alarm sounded during the fire event.
- The visual examination of a water heater during a scene examination resulting in an opinion about whether the appliance could have caused a fire.



ATF-LS-FRL Engineering Activities	ID: 7701
	Revision: 2
Authority: Technical Leader	Page: 4 of 7
Original maintained by Quality Programs; copies are uncontrolled.	

### 5.3. Procedure for Physical Examination Activities

Figure 3 shows a flow chart of the process followed for physical examination activities. Each step in the process is described in the text following the figure.

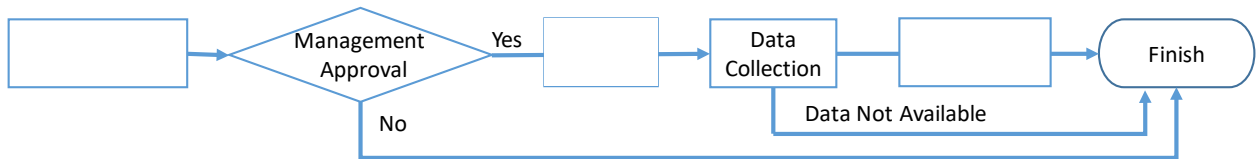

Figure 3. Flow Chart of Process for Physical Examination Activities

5.4. Client Request – Client requests for Physical Examination activities are received in one of three ways.

5.4.1. Evidence Transmittal – The first request type is the evidence transmittal form that the client sends with evidence that is sent to the laboratory.

5.4.2. External Request – The client requests a physical examination activity that will not be performed at the laboratory.

5.4.3. Scene Examination – During scene examinations, the engineer is expected to perform examinations on items as needed in the field. When an engineer determines that an examination cannot be completed during the scene examination, the engineer informs the client so that the client can decide whether to send the item to the laboratory as evidence.

5.5. Management Approval - Management approval is required for Physical Examination activities. After the initial approval, the manager has the option to cancel a Physical Examination activity if required data collection information is not available, see 8.3. The form of the management approval depends on the type of client request.

5.5.1. Evidence Transmittal – When the client submits the evidence to the laboratory with an evidence transmittal form, the manager indicates the approval of the request by assigning the project to an engineer in the Laboratory’s project management system.

5.5.2. External Request – When a request is received from a client for a physical examination activity that will not be conducted at the laboratory, the manager indicates the approval of the request by opening a project in the Laboratory’s project management system.



ATF-LS-FRL Engineering Activities	ID: 7701
	Revision: 2
Authority: Technical Leader	Page: 5 of 7
Original maintained by Quality Programs; copies are uncontrolled.	

5.5.3. Scene Examination – When the physical examination activity can be completed during the scene examination or in a reasonable amount of time after the scene examination, the physical examination activity is considered part of the scene examination project and no further approval is required.

5.6. Data collection – Engineers conduct data collection activities to develop in the information that is needed for the analysis. Data collection is described in section 7.

5.7. Analysis – The engineer uses their experience, training, and education to analyze the data that was collected and to develop an opinion.

5.8. Finish – The activities for the project will be recorded, reviewed and documented as defined in section 8.

6. Analysis Activities:

6.1. Analysis activities are conducted to answer a client’s questions about aspects of the incident. Analysis projects produce laboratory reports with conclusions and opinions.

Figure 4 shows a flow chart of the process followed for Analysis activities. Each step in the process is described in the text following the figure.

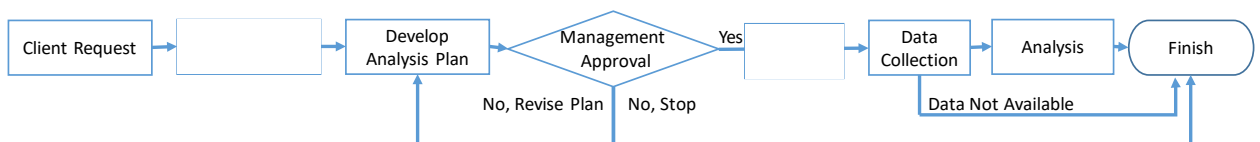

Figure 4. Flow Chart of Process for Analysis Activities

6.2. Client Request – The client sends a memo to the laboratory requesting assistance in answering questions about aspects of the incident.

6.3. Preliminary Data collection – Engineers conduct an initial data collection activity to develop in the information that is needed to develop an analysis plan. Data collection is described in section 7.

6.4. Develop Analysis Plan – The engineer develops a project plan that will assist the client to answer the questions that were posed in the request memo.

6.5. Management Approval – The manager reviews the analysis plan and makes a decision about whether to approve the project. As part of the review process, the manager can convene a panel of subject matter experts to review and provide feedback about the analysis plan. After the initial approval, the manager has the option to cancel the activity if required data collection information is not available, see 8.3. The manager has three options to approve a data analysis plan:



ATF-LS-FRL Engineering Activities	ID: 7701
	Revision: 2
Authority: Technical Leader	Page: 6 of 7
Original maintained by Quality Programs; copies are uncontrolled.	

6.5.1. Yes – The manager approves the project plan. The manager indicates the approval of the request by opening a project in the Laboratory’s project management system.

6.5.2. No, Revise Plan – The manager instructs the engineer to revise the plan and then resubmit the plan for approval.

6.5.3. No, Stop – The manager does not approve the analysis plan and decides that no further work should be done to develop a plan to answer the client’s question.

6.6. Data collection – Engineers conduct data collection activities to develop in the information that is needed to for the analysis. Data collection is described in section 7.

6.7. Analysis – The engineer uses their experience, training, and education to analyze the data that was collected and to develop an opinion.

6.8. Finish – The activities for the project will be recorded, reviewed and documented as defined in section 8.

## 7. Data Collection

7.1. Collecting and generating information to support the FRL activities is an essential function at FRL. Obtaining information usually takes time and is usually an on-going activity throughout the process. Often the engineer will make a list of the types of information that is needed and start the process of obtaining the information. The engineer is allowed to move to subsequent steps in the process when they decide that enough of the required information will become available.

### 7.2. Types of Data Collected

The types of data that is collected and generated for FRL Activities include, but are not limited to the following:

- Engineering Calculations
- Experimental Data
- Investigative Reports
- Literature Search
- Manufacturer Documentation
- Microscopic examinations
- Photographs
- Scene examination documentation
- Visual examinations



ATF-LS-FRL Engineering Activities	ID: 7701
	Revision: 2
Authority: Technical Leader	Page: 7 of 7
Original maintained by Quality Programs; copies are uncontrolled.	

- Witness statements

### 7.3. When Required Data Is Unavailable

Sometimes data that is required for the activity will not be available. If the engineer determines information that is essential to the activity will not become available, the engineer informs their manager who will decide whether to cancel the activity or to develop a new plan.

## 8. Finish

### 8.1. Manager Does Not Approve Activity

The process for when a manager does not approve an activity depends on the form of the client request.

8.1.1. Evidence Transmittal – When a manager decides not to perform an activity requested on an evidence transmittal form, the manager shall follow the procedure defined in ATF-LS-7.1.

8.1.2. Written Request - When a manager decides not to perform an activity that a client requested in a written request, (e.g. memo, email, etc.), the manager will respond in writing (i.e. an email). The manager will store a copy of the client request and the response in an administrative project in FireTOSS.

8.1.3. Phone Request – When a manager decides not to perform an activity that a client requested via phone, the manager will inform the client and make a record of the communication in FireTOSS.

### 8.2. Activity Completed

When the activity has been completed records created by the activity shall be stored in accordance with ATF-LS-7.5. The technical and administrative reviews shall be conducted in accordance with ATF-LS-7.7.1. The results of the activity shall be reported in accordance with ATF-LS-7.8.

### 8.3. Activity Not Completed Because Required Data Is Not Available

When an activity cannot be completed because information required for the activity is not available, the lead engineer shall inform the manager. The manager will inform the client that the activity cannot be completed because the required information was not available. A record of the communication will be stored in FireTOSS. The project for the activity shall be closed.



ATF-LS-FRL Engineering Calculations	ID: 1554 Revision: 4
Authority: Technical Leader	Page: 1 of 3
Original maintained by Quality Programs; copies are uncontrolled.	

**1. Title:** Procedure for use of Engineering Calculations

**2. Scope:**

**2.1** This procedure provides the approach accepted by the Fire Research Laboratory (FRL) for use of engineering calculations. Engineering calculations typically include calculations done by hand and by spreadsheets or other computer-aided methods.

**2.2** This procedure is not meant to restrict the methods of analysis available to the engineers, nor does it recommend particular calculations over others.

**3. Description:**

**3.1** The choice of which method of calculation is used to solve a particular problem will impact the accuracy of the outcome and the level of uncertainty inherent in the results. Before using a given engineering calculation the engineer must be aware of its inherent limitations and assumptions. The project engineer and the reviewing engineer are responsible for verifying that the calculations being used are appropriate for the given scenario and that sufficient analysis is conducted to identify possible sources and ranges of error.

**3.2** The primary source of engineering calculation information for FRL projects should be taken from engineering texts or peer reviewed journal articles. It is permitted that other references or derivation of calculations be used as long as proper documentation is provided (see ATF-LS-FRL Technical Research) and approval is granted from the Technical Reviewer.

**4. Uncertainty:**

There is a level of uncertainty involved in all engineering calculations that can be addressed in one of several ways, as appropriate for the particular problem. The project engineer should choose one of the following methods to address uncertainty, as appropriate for the particular case:

- A) Uncertainty can be addressed by bounding the variables involved in the equations and providing a range of possible values for each calculation.
- B) Uncertainty can be directly calculated using the methods described in NIST Technical Note 1297 “Guidelines for Evaluating and Expressing the Uncertainty of NIST Measurement Results”.
- C) Uncertainty can be measured using a least-squares analysis, Monte Carlo analysis or other similar statistical technique.
- D) In some instances qualitative statements are appropriate to describe the effects of any assumptions made during the calculation process.

**5. Procedure:**

**5.1** The procedure for the use of engineering calculations is as indicated in the flow chart below.



ATF-LS-FRL Engineering Calculations	ID: 1554 Revision: 4
Authority: Technical Leader	Page: 2 of 3
Original maintained by Quality Programs; copies are uncontrolled.	

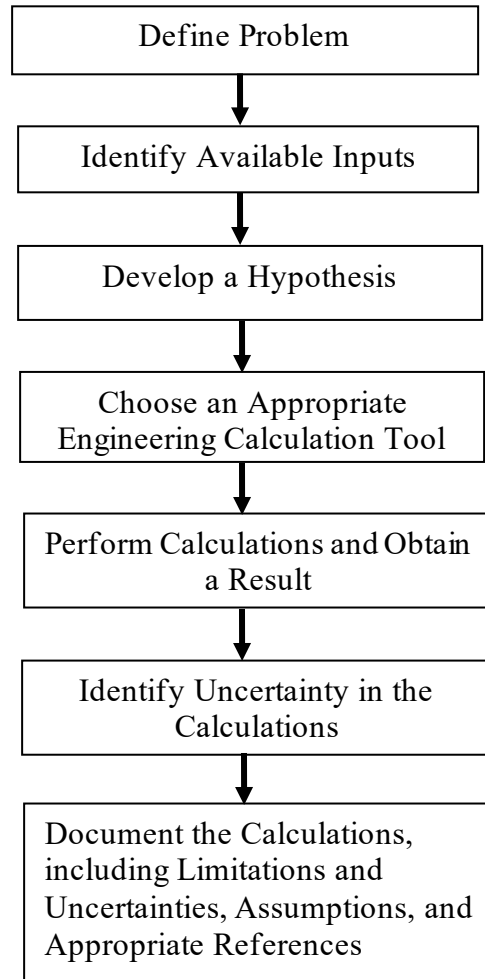

**5.2** The procedural steps for the use of engineering calculations as illustrated in the flow chart above are as follows:

*Step 1 - Define the Problem:* Identify the problem by establishing the goals of the engineering calculations and determining the desired output from the analysis.

*Step 2 - Identify Available Inputs:* Gather all relevant input variables that are available and determine whether there is enough information to proceed with an analysis. If there is not enough information available for an engineering calculation than an evaluation should be made as to whether computer modeling or laboratory testing will be required to solve the problem.

*Step 3 - Develop a Hypothesis:* Use engineering judgment and other available resources to develop a hypothesis.



ATF-LS-FRL Engineering Calculations	ID: 1554 Revision: 4
Authority: Technical Leader	Page: 3 of 3
Original maintained by Quality Programs; copies are uncontrolled.	

*Step 4 - Choose an Appropriate Engineering Tool:* Choose a method of analysis to complete the required engineering calculations, starting with one of the approved references listed in section 3.2 of this procedure. If an appropriate tool is not available in any of these references outside sources may be used with proper documentation.

*Step 5 - Perform Calculations:* Calculations should be performed in a way that can be recorded (e.g. written notes or saved excel spreadsheets). These calculations should include sufficient documentation so that they can be easily reviewed and/or recreated by another engineer.

Calculations and data transfers which were not derived from a validated electronic process should be checked. The case record or analysis report should include an indication that such checks have been carried out and by whom.

*Step 6 - Identify Uncertainty:* Identify and quantify the uncertainty involved in the calculations in accordance with Section 4 of this procedure.

*Step 7 – Documentation:* Documentation shall be in accordance with the FRL document ATF-LS-FRL Technical Research and will provide sufficient detail such that another engineer with a similar level of training can review and/or recreate the engineering calculation work.



ATF-LS-FRL FireTOSS Calculation Documentation Requirements	ID: 15186 Revision: 1
Authority: Technical Leader	Page: 1 of 4
Original maintained by Quality Programs; copies are uncontrolled.	

## 1. Title: FireTOSS Calculation Documentation Requirements

### 2. Scope

- 2.1. This document lists the requirements for documenting and reviewing calculations that are incorporated into the compiled FireTOSS code that is used by the Bureau of Alcohol, Tobacco, Firearms and Explosives (ATF), Fire Research Laboratory (FRL).
  - 2.1.1. FireTOSS is the set of custom software applications that make up the FRL's Laboratory Information Management System (LIMS) [1].
- 2.2. The Calculations program is an application that uses instrument data and parameters to calculate engineering quantities and perform statistical analysis of experimental data. The program is run at the conclusion of every experiment that is run in the FRL.
- 2.3. The Calculations program source code, and all required documentation, is maintained by a designee of the FRL Laboratory Section Chief (LSC). Changes to the Calculations program are tracked via SVN repository.

### 3. Description

- 3.1. Documentation of the Calculations program falls into three categories: documentation and review of analysis subroutines, instrument review, and unit conversion review. Analysis subroutines contain the underlying engineering and statistical algorithms in the Calculations program. They shall be documented according to the requirements listed in the Computer Algorithm Documentation section below. Each analysis subroutine shall be subject to technical review according to the requirements listed in the Computer Algorithm Review section.
- 3.2. FireTOSS instruments for which engineering or statistical calculations are performed shall be subject to technical review according to the requirements listed in the FireTOSS Instrument Calculation Review section.
- 3.3. All unit conversions shall be subject to technical review according to the requirements listed in the FireTOSS Unit Conversion Section.
- 3.4. A list of all analysis subroutines, instruments, and unit conversions in the Calculations program shall be maintained by the (LSC) or designee

### 4. Uncertainty

- 4.1. Uncertainty is addressed in the Technical Reference documents associated with individual instruments.



ATF-LS-FRL FireTOSS Calculation Documentation Requirements	ID: 15186 Revision: 1
Authority: Technical Leader	Page: 2 of 4
Original maintained by Quality Programs; copies are uncontrolled.	

## 5. Procedure

### 5.1. Computer Algorithm Documentation

5.1.1. The Computer Algorithm Documentation form provides the reader with a general understanding of the algorithm [2]. The documentation, at a minimum, shall provide the following information:

5.1.1.1. A general description of the program/routine which includes the following information:

- 5.1.1.1.1. Name of program / routine
- 5.1.1.1.2. Type (Standalone program or subroutine)
- 5.1.1.1.3. Unique identification (UI) number
- 5.1.1.1.4. A description of the purpose
- 5.1.1.1.5. Limitations of the algorithm
- 5.1.1.1.6. Language
- 5.1.1.1.7. A list of input parameters, including the data type and units
- 5.1.1.1.8. A list of output parameters, including the data type and units
- 5.1.1.1.9. A list of error codes
- 5.1.1.1.10. A listing of the code
- 5.1.1.1.11. A revision history

### 5.2. Computer Algorithm Review

5.2.1. Each analysis algorithm in the FireTOSS calculation program shall be subject to a technical review. The Computer Algorithm Review Form serves as a guide for this review [3].

5.2.2. The review cannot be performed by the author of the algorithm.

5.2.3. The review is divided into four components.

5.2.3.1. The first component is a general review of functionality and a check on whether the code incorporated version control and was archived correctly.

5.2.3.2. The second component is an administrative review of the Computer Algorithm Documentation Form to ensure that it is complete and accurate.

5.2.3.3. The third component is a review of the code. The primary focus of this review component is to ensure that the code has been written in a way that makes sense -i.e. that meaningful variable name have been used and that it has been documented adequately. There is also a check to ensure that any underlying theory has been implemented correctly.



ATF-LS-FRL FireTOSS Calculation Documentation Requirements	ID: 15186 Revision: 1
Authority: Technical Leader	Page: 3 of 4
Original maintained by Quality Programs; copies are uncontrolled.	

5.2.3.4. The fourth review component consists of a comparison against independent code using a minimum of five data sets. The reviewer is encouraged to use data sets that test the limits of the algorithm.

### 5.3. FireTOSS Instrument Calculation Review

5.3.1. While each analysis algorithm is reviewed independently, the calculations program calls multiple subroutines for instruments associated with an experiment at the conclusion of each experiment.

5.3.2. A review shall be performed to ensure that calculations are performed correctly and that data and parameters are stored correctly for each instrument.

5.3.3. The FireTOSS Instrument Calculation Review Form is intended to serve as a guide for the review of calculations associated with individual instruments [4].

### 5.4. FireTOSS Unit Conversion Review

5.4.1. Engineering quantities can be expressed in a wide range of units. FireTOSS uses a base system of units but has the capability to express quantities in alternate units.

5.4.2. Quantities are expressed in alternate units through a linear conversion.

5.4.3. Each conversion shall be reviewed, and the review shall be documented using the FireTOSS Unit Conversion Review Form [5].

## 6. Documentation

### 6.1. Computer Algorithm Documentation

6.1.1. The document file name shall be structured as follows (FRL Computer Algorithm Documentation\_Algorithm Name XXXX) where XXXX represents the Unique identification (UI) number assigned to that algorithm and Algorithm Name shall be replaced with the actual Algorithm Name.

### 6.2. Computer Algorithm Review

6.2.1. The document file name shall be structured as follows (FRL Computer Algorithm Review Form\_Algorithm Name XXXX) where XXXX represents the Unique identification (UI) number assigned to that algorithm and Algorithm Name shall be replaced with the actual Algorithm Name.

### 6.3. FireTOSS Instrument Calculation Review

6.3.1. The document file name shall be structured as follows (FRL FireTOSS Instrument Calculation Review Form – Instrument) where Instrument shall be replaced with the actual Instrument Name.

### 6.4. FireTOSS Unit Conversion Review

6.4.1. The document file name shall be structured as follows (FRL FireTOSS Unit Conversion Review Form)



ATF-LS-FRL FireTOSS Calculation Documentation Requirements	ID: 15186 Revision: 1
Authority: Technical Leader	Page: 4 of 4
Original maintained by Quality Programs; copies are uncontrolled.	

## 7. References

1. FireTOSS LIMS Documentation, ATF Fire Research Laboratory.
2. FRL Computer Algorithm Documentation, ATF-FRL-F-127.
3. FRL Computer Algorithm Review Form, ATF-FRL-F-128.
4. FRL FireTOSS Instrument Calculation Review Form, ATF-FRL-F-129.
5. FRL FireTOSS Unit Conversion Documentation, ATF-FRL-F-130.



ATF-LS-FRL Handling of Items Containing Lithium Batteries and Cells	ID: 14050 Revision: 1
Authority: Technical Leader	Page: 1 of 3
Original maintained by Quality Programs; copies are uncontrolled.	

1. **Title:** Procedure for the Handling of Items Containing Lithium Cells or Batteries
2. **Scope:**
  - 2.1. This document establishes procedures for the handling of items containing lithium cells or batteries.
  - 2.2. This document does not set the requirements for the storage of lithium cells or batteries outside of the FRL or items not received as part of casework or used in research or testing.
  - 2.3. This guideline is generally based on the most recent version of the following regulations:
    - 2.3.1. 49 CFR 173.185 – Lithium Cells and Batteries
  - 2.4. This document was developed by the Fire Research Laboratory as an internal, working document. This document was not developed with the intent of setting a standard for other laboratories. While this document may be a helpful guide for other forensic laboratories in developing their management system requirements, they were designed for use specifically by the Fire Research Laboratory.
3. **Description:**
  - 3.1. The Fire Research Laboratory conducts examinations of lithium cells or batteries submitted as evidence. The hazards associated with these items require special care and handling.
4. **Safety**
  - 4.1. Damaged lithium cells and batteries have the potential to contain stranded energy, which could cause thermal runaway. The byproducts of thermal runaway include fire, toxic gases, chemicals, and projectile hazards.
  - 4.2. The examiner shall follow the requirements of the FRL Safety Manual.
  - 4.3. The minimum personal protective equipment required for the handling of damaged lithium cells or batteries include exam gloves (nitrile, latex, etc.), eye protection, and a laboratory coat or other protective garment (e.g., Nomex suit or turnout gear).
5. **Items Received at the FRL**
  - 5.1. Communication with the customer or evidence technician should identify whether submitted items contain lithium cells or batteries.
    - 5.1.1. This should be documented on the Laboratory Exam Request form.
  - 5.2. Once received by the FRL, items containing lithium cells or batteries should be placed in the FRL's battery storage cabinet located in the large evidence storage bay.
  - 5.3. Items containing lithium cells or batteries should be stored in the FRL's battery storage cabinet located in the FRL Exam Room whenever they are not actively being examined.
6. **Shipping**
  - 6.1. Care should be taken to prevent further damage to or shorting of lithium cells or batteries when packaging items for storage or shipment.



ATF-LS-FRL Handling of Items Containing Lithium Batteries and Cells	ID: 14050 Revision: 1
Authority: Technical Leader	Page: 2 of 3
Original maintained by Quality Programs; copies are uncontrolled.	

- 6.2. Guidance should be provided to the customer or members of the investigative team on the safe handling, storage, and transportation of lithium batteries or cells.
- 6.3. 49 CFR 173.185, subpart (f) details the requirements for the transportation of damaged, defective, or recalled cells or batteries. In summary:
  - 6.3.1. Damaged or defective lithium cells or batteries must be transported by highway, rail, or vessel (e.g. FedEx Ground).
  - 6.3.2. Each cell or battery must be placed in individual, non-metallic inner packaging that completely encloses the cell or battery.
  - 6.3.3. The inner packaging must be surrounded by cushioning material that is non-combustible, electrically non-conductive, and absorbent.
    - 6.3.3.1. Examples include sand, cat litter, vermiculite and CellBlockEX media.
  - 6.3.4. Each inner packaging must be individually placed in an appropriate wood, metal, or solid plastic container as defined in the CFR.
  - 6.3.5. The outer container must be labeled with the following: “Damaged/Defective Lithium-Ion Battery” or “Damaged/Defective Lithium-Metal Battery” using letters that are at least ½” tall.
  - 6.3.6. The outer container should have the following lithium battery mark (shown below)
    - 6.3.6.1. The appropriate UN number(s) must be placed in the location denoted by “UN ####”.
      - 6.3.6.1.1. UN3480 for lithium-ion batteries or cells, or UN3481 for batteries/cells contained within equipment.
      - 6.3.6.1.2. UN3090 for lithium metal batteries or cells or UN3091 for batteries/cells contained within equipment.
    - 6.3.6.2. The mark must be in the form of a rectangle or square with hatched edging. The mark must be not less than 100 mm (3.9 in.) wide by 100 mm (3.9 in.) high, and the minimum width of the hatching must be 5 mm (0.2 in.), except marks of 100 mm (3.9 in.) wide by 70 mm (2.8 in.) high may be used on a package containing lithium batteries when the package is too small for the larger mark.
    - 6.3.6.3. The symbols and letters must be black on white or suitable contrasting background and the hatching must be red.



ATF-LS-FRL Handling of Items Containing Lithium Batteries and Cells	ID: 14050 Revision: 1
Authority: Technical Leader	Page: 3 of 3
Original maintained by Quality Programs; copies are uncontrolled.	



## 7. Disposal

- 7.1. The disposal of items containing lithium batteries or cells shall be done according to applicable regulations.
- 7.2. Lithium batteries and cells shall not be placed in the regular waste system.
- 7.3. The FRL utilizes a contracted lithium battery disposal provider. Consult with the FRL Collateral Duty Safety Officer (CDSO) for coordination of batteries or cells.



ATF-LS-FRL Heat Flux Transducer - Standard Operating Procedures	ID: 1576 Revision: 4
Authority: Technical Leader	Page: 1 of 2
Original maintained by Quality Programs; copies are uncontrolled.	

## 1. Scope

This document contains the Standard Operating Procedures (SOP) for the heat flux transducers used at the Bureau of Alcohol, Tobacco, Firearms and Explosives (ATF) Fire Research Laboratory (FRL).

## 2. Required Supplies

- Heat Flux Transducer
- Heated water source with constant flow
- Water transport tubing (metal or plastic, depending on expected heat exposure)
- Data acquisition box
- Data acquisition connectivity (ethernet cable, extension wire for millivolt data signal)
- Electrical power for data acquisition box and water heater
- FireTOSS client computer
- Thermal protection for wires and tubing (e.g., ceramic fiber insulation, aluminum foil)

## 3. Start Up Procedures

### A. Set-Up

1. The calibration marking on the transducer shall be checked to confirm that the instrument is calibrated.
2. Transducers shall be connected to the data acquisition hardware using the smallest voltage input range that will bound the output range of the transducer. This is usually the 20 mV range.
3. All heat flux transducers shall be connected to a constant temperature flowing water source.
4. Water lines and wires connected to the heat flux transducer shall be protected if it is anticipated that they will be exposed to excessive heat during the experiment.

### B. Pre-Test

1. It shall be verified that water is flowing through each heat flux transducer.
2. A baseline reading shall be recorded with the transducer prior to conducting experiments or whenever the water supply temperature changes. The baseline



ATF-LS-FRL Heat Flux Transducer - Standard Operating Procedures	ID: 1576 Revision: 4
Authority: Technical Leader	Page: 2 of 2
Original maintained by Quality Programs; copies are uncontrolled.	

value shall be the average heat flux measured during a period with a minimum 2-minute duration.

3. During the baseline reading, the water temperature will be stable and at the same temperature as will be used during the experiments.
4. The water temperature used to cool the transducer shall be a minimum of 5 °C (9 °F) above ambient. This temperature shall be recorded on the data sheet.

#### **4. Experiment Procedures**

- A. Water shall be supplied continuously at a constant temperature.
- B. The output of the heat flux transducer shall be recorded for the duration of the experiment.
- C. If the heat flux transducer must be removed prior to the end of the experiment due to experiment design or impending damage to the instrument, then the elapsed time at which the transducer was removed and the reason for instrument removal shall be recorded on the data sheet.

#### **5. Shut Down Procedures**

- After the experiment, heat flux transducers in areas where they may have been damaged shall be examined for visible damage or surface dirt.

#### **6. Maintenance Procedures**

- If damage or surface dirt is observed the instrument shall be cleaned and/or repaired according to manufacturer's documentation.
- If the heat flux exceeded 150% of the maximum transducer range during any point of a test, then the instrument shall be taken out of service until its correct operating condition is confirmed.

#### **7. Calibration**

- Heat Flux Transducer calibration is performed by the manufacturer.



ATF-LS-FRL Hot Wire Anemometer - Standard Operating Procedures	ID: 1595 Revision: 6
Authority: Technical Leader	Page: 1 of 13
Original maintained by Quality Programs; copies are uncontrolled.	

## 1. Scope

This document contains the Standard Operating Procedure (SOP) for hot wire anemometers. Hot wire anemometers are used to measure the air velocity in experiments at the Bureau of Alcohol, Tobacco, Firearms and Explosives (ATF) Fire Research Laboratory (FRL).

## 2. Required Supplies

### A. Hot Wire Anemometer

- Four models of hot wire anemometers are available. Table 1 summarizes the features of each instrument and Figures 1-4 show the hot wire anemometers.

**Table 1. Description of Hot Wire Anemometers**

Model	Velocity Range	Remote Velocity Probe	Digital Display	Signal Output	Power/Signal Connection
FMA-900-MA	0.05 -0.51 m/s (10-100 fpm)	No	No	4-20 mA	Terminal Block
FMA-901-I	0.05 -1.0 m/s (10-200 fpm)	No	No	4-20 mA	7 Pin Connector
FMA-904-I-R	0.05 -10 m/s (10-2000 fpm)	Yes	No	4-20 mA	7 Pin Connector
FMA-1001R-VI	0 - 5.1 m/s (0-1000 fpm)	Yes	Yes	0-5 VDC	8 or 10 Pin Connector

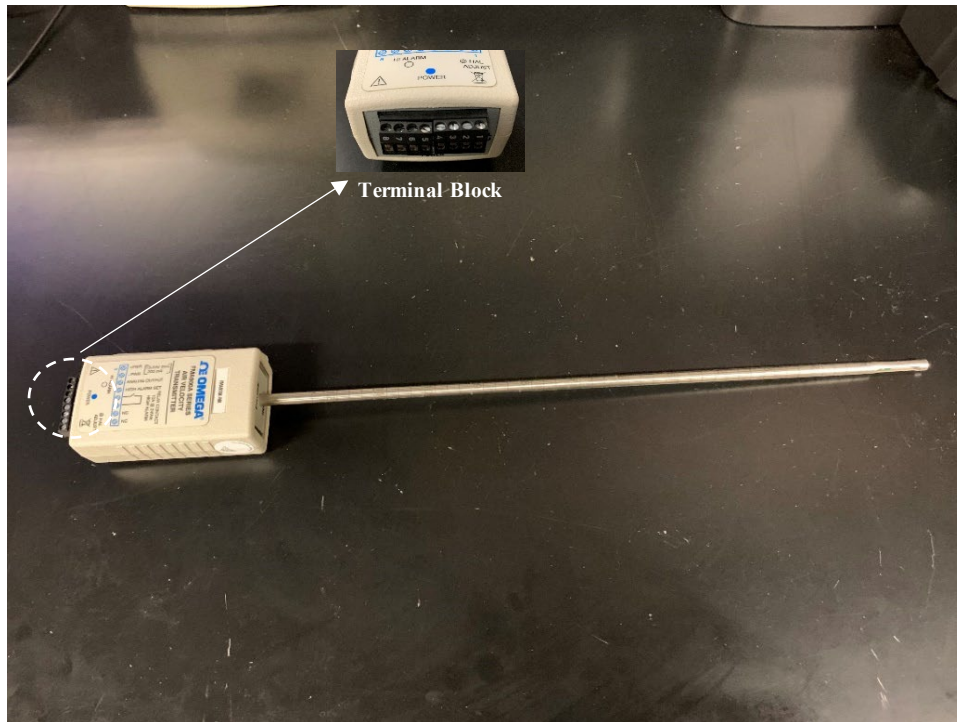

**Figure 1. FMA-900-MA - Probe Attached to Electronics Box**

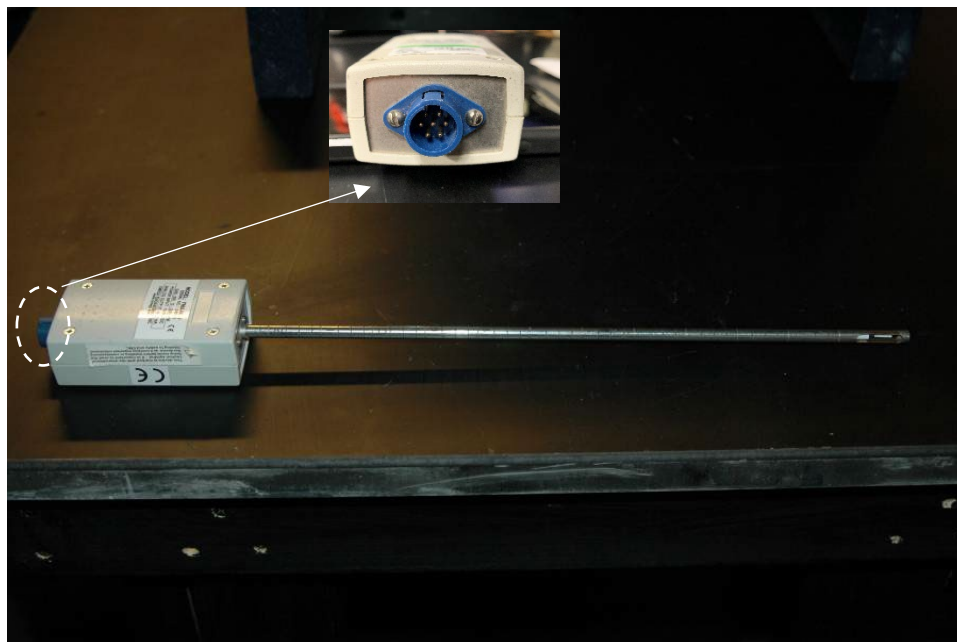

**Figure 2. FMA-901-I - Probe Attached to Electronics Box**

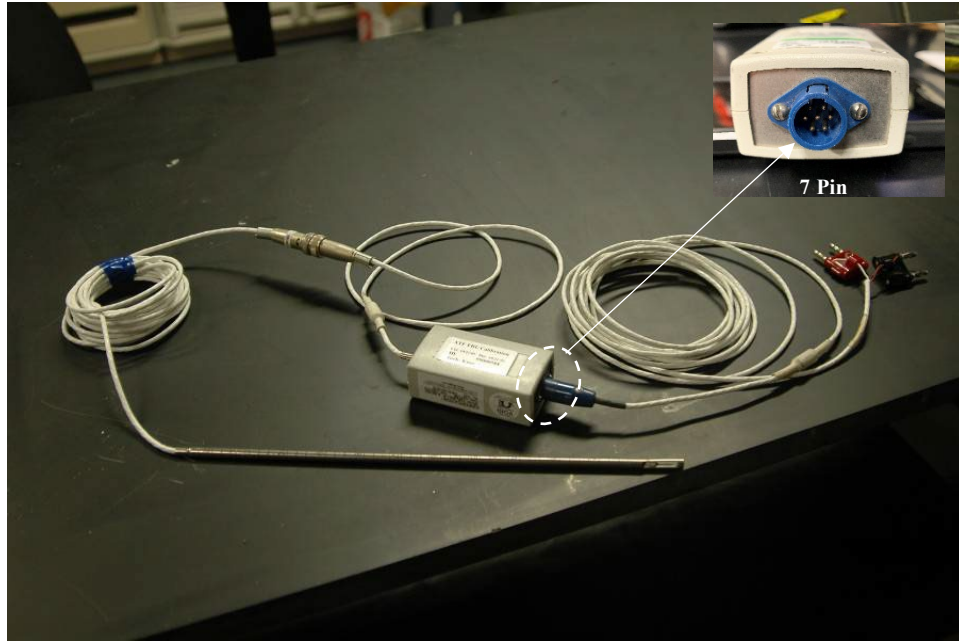

Figure 3. FMA-904-I-R – Remote Probe

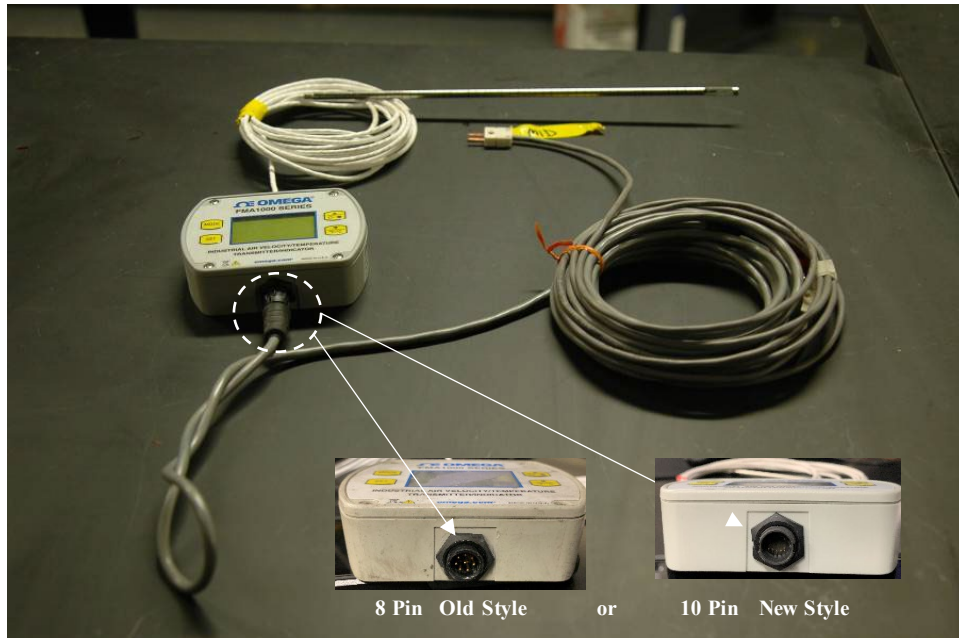

Figure 4. FMA-1001R-VI – Remote Probe and Digital Display



## B. DAQ/Power Supply Patch Panel

- Patch panel (Figure 5) connects the hot wire anemometers to the power supply.
- Dedicated power supplies are installed in the patch panel (unregulated linear power supply Omega model U24Y101 with an output rating of 24 VDC @ 1000 mA).
- Patch panel also converts the 4-20 mA output signal of the FMA 900 series hot wire anemometers to a 1-5 VDC output, using a 250 ohm resistor mounted to the back of the patch panel (Figure 6).



**Figure 5. DAQ/power supply patch panel for hot wire anemometers**

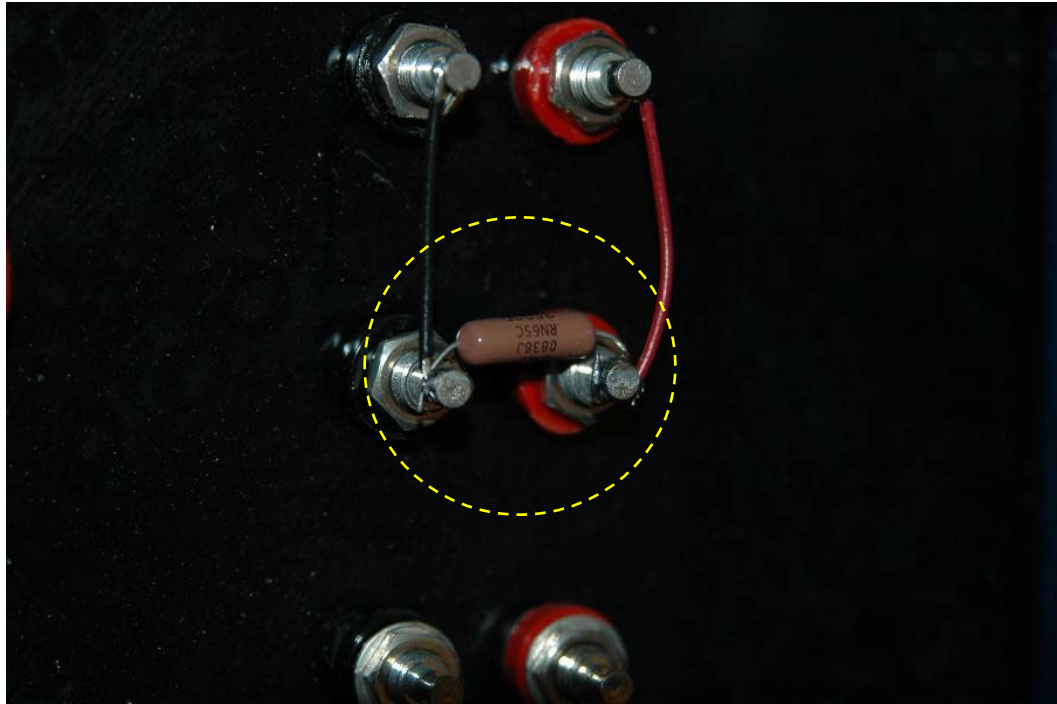

Figure 6. A 250 ohm resistors used in patch panels

### C. Cables/Wires

- **FMA-900-MA**

1. Signal/power cable

- One end has exposed wires to connect to the terminal block on the hot wire anemometer and the other end has two banana plugs for power and the output signal.

2. Jumper cable

- One end has a banana plug and the other end has a DAQ voltage connector (male).

3. DAQ Box voltage extension wire

- One end has a DAQ voltage connector (male), and the other end has a DAQ voltage connector (female).



ATF-LS-FRL Hot Wire Anemometer - Standard Operating Procedures	ID: 1595 Revision: 6
Authority: Technical Leader	Page: 6 of 13
Original maintained by Quality Programs; copies are uncontrolled.	

- ***FMA 900 I and FMA 900 IR***

1. Signal/power cable with connector

- One end has a 7 pin (female) connector that attaches to the hot wire anemometer and other end has two banana plug connectors for power and the output signal.

2. Jumper cable

- One end has a banana plug to connect to the patch panel and the other end has a DAQ voltage connector (male).

3. DAQ Box voltage extension wire

- One end has a DAQ voltage connector (male), and the other end has a DAQ voltage connector (female).

- ***FMA 1000 Series models***

1. Signal/power connector cable

- One end has either an 8 pin connector (female) or an 10 pin connector (female) that attaches to the hot wire anemometer, and the other end has one banana plug connector (power) and one DAQ voltage connector (signal).
  - The signal/power cable used with the 10-pin connector has six wires, of which only three wires are used (red, black, white).
  - The signal/power cable used with the 10-pin connector also has a USB cable attached, which is not used.

2. DAQ Box voltage extension wire

- One end has a DAQ voltage connector (male), and the other end has a DAQ voltage connector (female).

#### **D. Thermocouple**

- Type-K, 24 American Wire Gauge (AWG), Special Limits of Error (SLE)
- One thermocouple required per hot wire anemometer

#### **E. Data Acquisition System**

- Yokagowa DAQ box with power and communication cables
  - Voltage module (0-6 volt range, 1 channel required per hot wire anemometer)
  - Thermocouple module (1 channel required per hot wire anemometer)



ATF-LS-FRL Hot Wire Anemometer - Standard Operating Procedures	ID: 1595 Revision: 6
Authority: Technical Leader	Page: 7 of 13
Original maintained by Quality Programs; copies are uncontrolled.	

### 3. Start-Up Procedures

1. Verify instrument is calibrated and will be throughout the test series.
2. Hot wire anemometers must be installed in the environment at least 5 minutes prior to testing to allow for ambient temperature compensation.
3. Determine location to mount hot wire anemometer.
  - a. Hot wire anemometers are intended to be used in clean air or nitrogen environments. Care should be taken to mount the hot wire anemometers away from flammable or hazardous gases such as combustion byproducts.
  - b. Hot wire anemometers can be mounted vertically or horizontally in open air or within pipes/ducts.
  - c. If mounting the hot wire anemometer within a duct or pipe, run a length of straight pipe before and after the hot wire anemometer. Consult manufacturer documentation for specific length requirements, which depend on the configuration of the piping system.
  - d. Align the sensor of the hot wire anemometers with the air flow. Make sure the air flow is perpendicular to the sensor window.
4. Place the patch panel near the location of the hot wire anemometers, so that the cables can reach the hot wire anemometers. Up to three hot wire anemometers can be attached to one patch panel.
5. Connect the appropriate signal/power cable to the hot wire anemometer.
  - In general, the signal/power cable consists of at least wires that are red, black, white, and green.
  - The red and black wires are used to supply the power to the hot wire anemometer (red to positive, black to negative).
  - The white and green wires are used to carry the hot wire anemometer's data signal from the electrical box to the data acquisition equipment (white to positive, green to negative).
    - For the instruments that have an output signal of 0-5 VDC, the green wire is not used. Instead, a second wire is joined to the black power wire (negative).



6. Select the position on the patch panel (# 1, 2, or 3) to connect the hot wire anemometer (Figure 7).

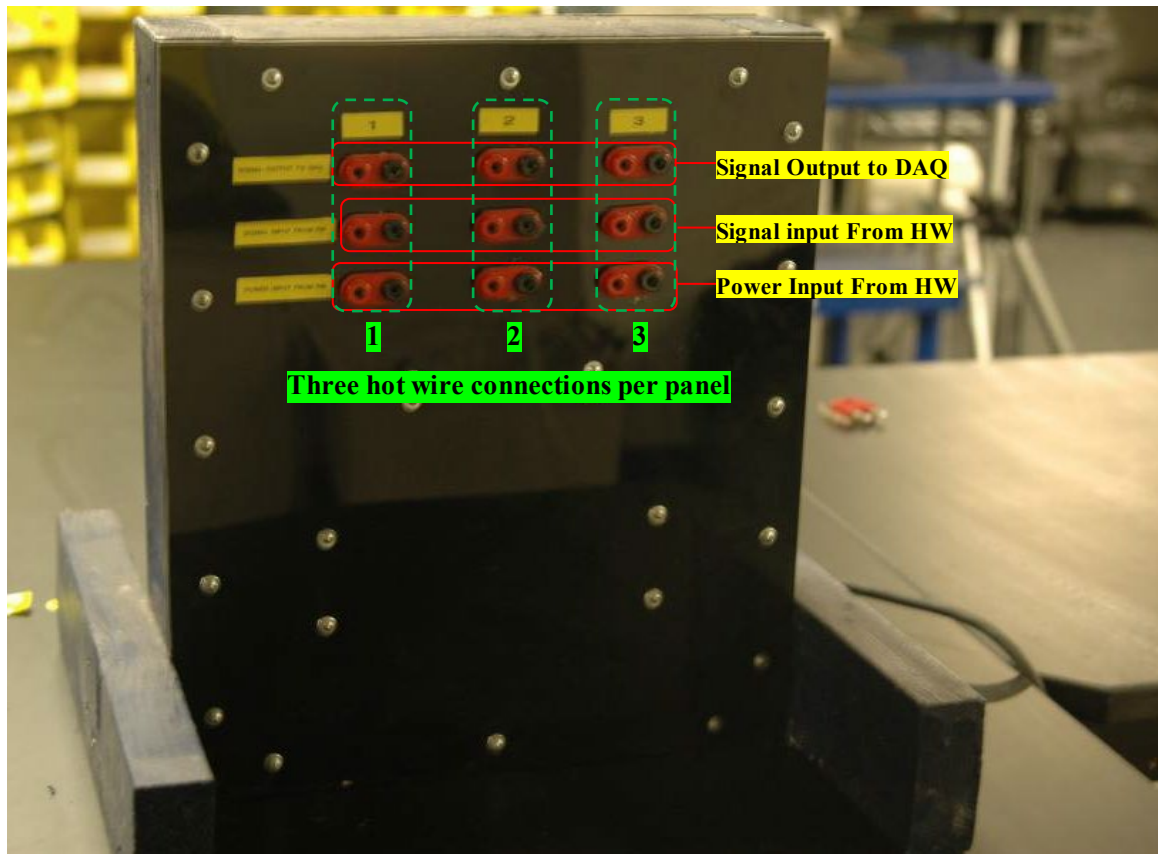

**Figure 7. Patch panel connections**

7. Use the following steps to connect the FMA 900 series instruments to the patch panel and DAQ box. Skip to Step 8 for the FMA 1000 series instruments.
  - a. Figure 8 shows the basic wire connections between the hot wire anemometer and the patch panel and DAQ box.
  - b. Connect the power/signal cable with the red/black wires to the bottom of the patch panel marked “*Power Input from HW*”.
    - Insert the banana plug attached to the red wire into the red plug and the banana plug attached to the black wire into the black plug.

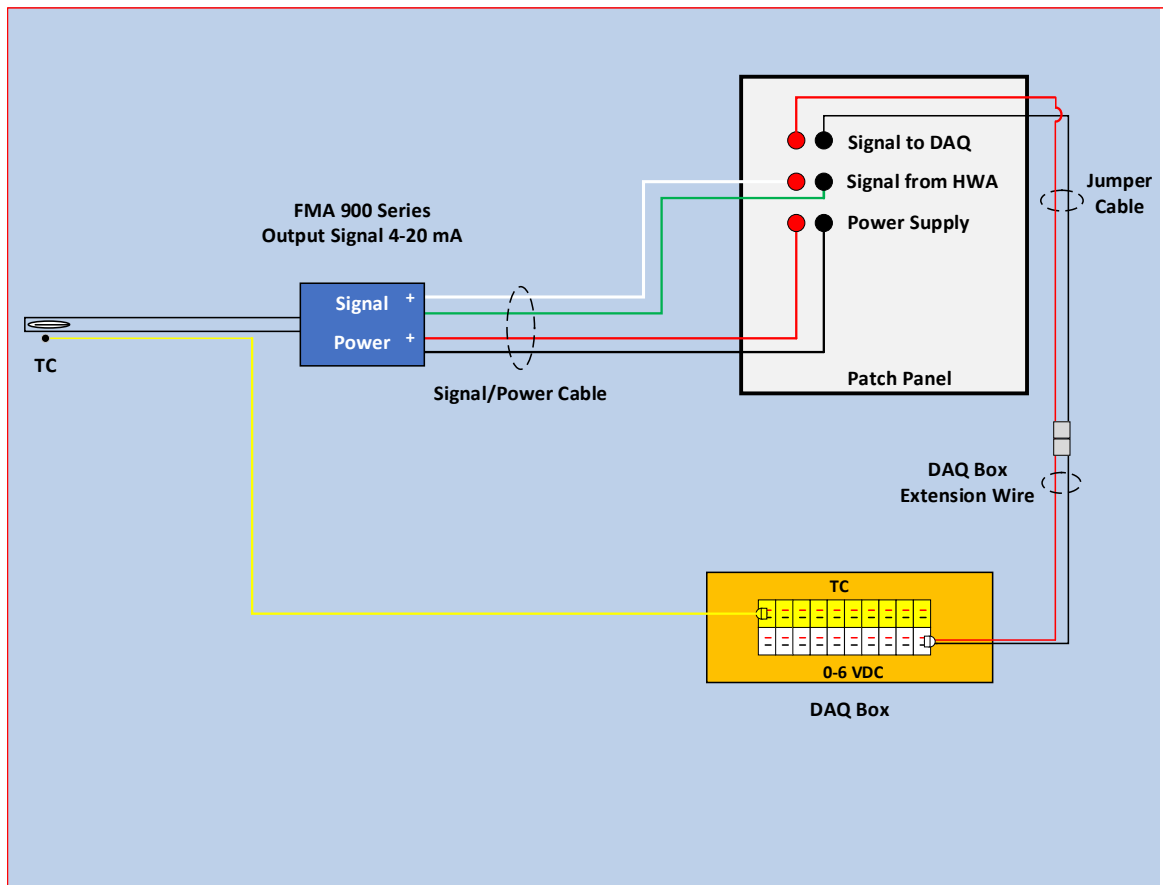

**Figure 8. Wire connections for FMA 900 Series hot wire anemometers with the 4-20 mA output signal**

- c. Connect the signal/power cable with the green/white wires to the middle of the patch panel marked “*Signal Input From HW*”.
  - Insert the banana plug attached to the *white* wire into the *red* plug and the banana plug attached to the *green* wire into the *black* plug.
- d. Connect the banana plug attached to the end of a jumper cable to the plugs located at the top of the patch panel marked “*Signal Output to DAQ*”.
  - Typically, the jumper cable will consist of a red or white wire (positive) and a black wire (negative).
- e. Connect the jumper cable to the DAQ box using an extension wire. Plug the wire into an open voltage channel (0-6 VDC) on the DAQ box.



ATF-LS-FRL Hot Wire Anemometer - Standard Operating Procedures	ID: 1595 Revision: 6
Authority: Technical Leader	Page: 10 of 13
Original maintained by Quality Programs; copies are uncontrolled.	

8. Use the following steps to connect the FMA 1000 series instruments to the patch panel and DAQ box.
  - a. Figure 9 shows the basic wire connections between the hot wire anemometer and the patch panel and DAQ box.

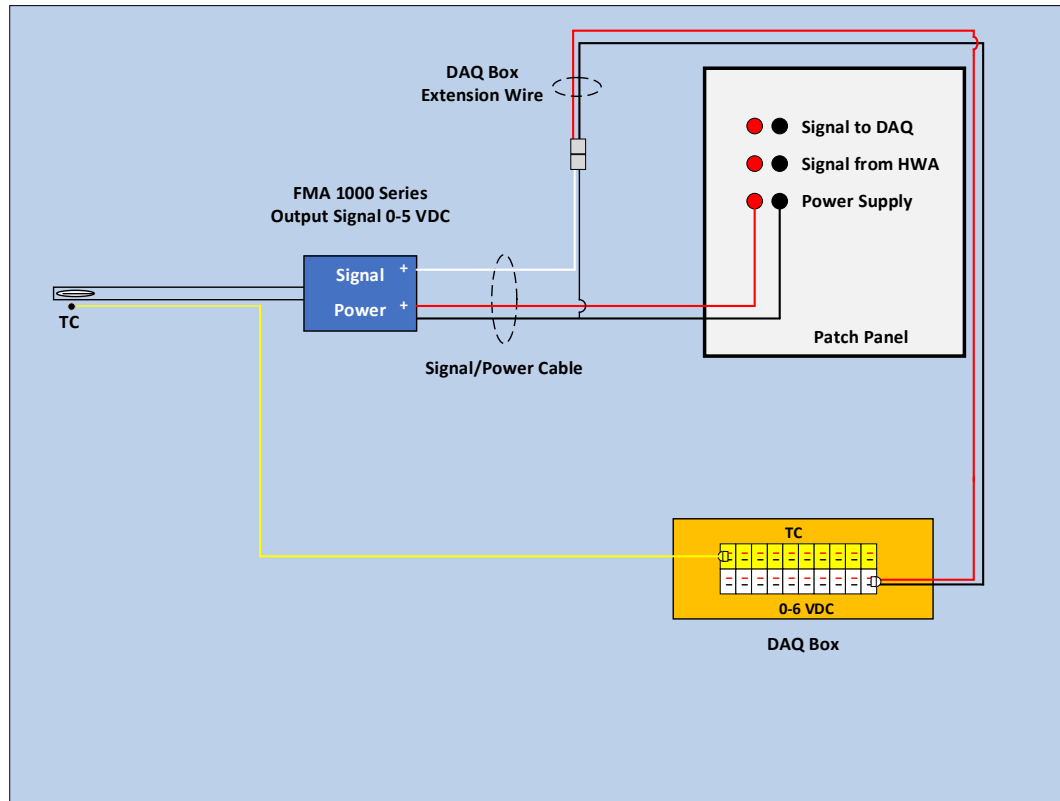

**Figure 9. Wire connections for the FMA 900 Series hot wire anemometers with a 0-5 VDC output signal**

- b. Connect the power/signal cable with the red/black wires to the bottom of the patch panel marked “Power Input from HW”.
        - Insert the banana plug attached to the red wire into the red plug and the banana plug attached to the black wire into the black plug.
      - c. Connect the output signal connector of the power/signal cable to an extension wire for the DAQ box. Plug the wire into an open voltage channel (0-6 VDC) on the DAQ box.
9. Install a single Type-K 24 AWG SLE thermocouple near the hot wire sensor to monitor the surrounding air temperature, if a thermocouple is not present.



ATF-LS-FRL Hot Wire Anemometer - Standard Operating Procedures	ID: 1595 Revision: 6
Authority: Technical Leader	Page: 11 of 13
Original maintained by Quality Programs; copies are uncontrolled.	

10. Plug the thermocouple into an open temperature channel on the DAQ box.
11. Verify the output signal of the hot wire anemometer and thermocouple using the data acquisition system.
  - a. The hot wire anemometer can be checked by *gently* blowing air across the sensor.
  - b. The thermocouple can be checked using a flame from lighter. Make sure that the flame *does not* contact the sensor of the hot wire anemometer.

#### 4. Experiment Procedures

1. Prior to the start of the test, verify the output signal of the hot wire anemometer and thermocouple.
2. During the test, record the output signal of the hot wire anemometer.
3. Monitor temperature of the surrounding air throughout the test.
4. If the surrounding air temperature exceeds 121 °C (250 °F) for remote sensing probes or 50 °C (122 °F) for attached probes, the hot wire anemometers must be taken out of service for the duration of the experiment. The elapsed time at which the hot wire instrument was taken out of service and the reason for its removal shall be recorded.
5. During the test, it may be necessary to totally remove the instrument from the setup, in order to prevent the instrument from being damaged by elevated temperatures. If the instrument is removed, then the time at which the hot wire anemometer was removed shall be reordered, along with the reason why.



ATF-LS-FRL Hot Wire Anemometer - Standard Operating Procedures	ID: 1595 Revision: 6
Authority: Technical Leader	Page: 12 of 13
Original maintained by Quality Programs; copies are uncontrolled.	

## 5. Shutdown/Post Test Procedures

1. After the experiment, check the sensor tip of the hot wire anemometer (Figure 10) for any visible damage or surface dirt.

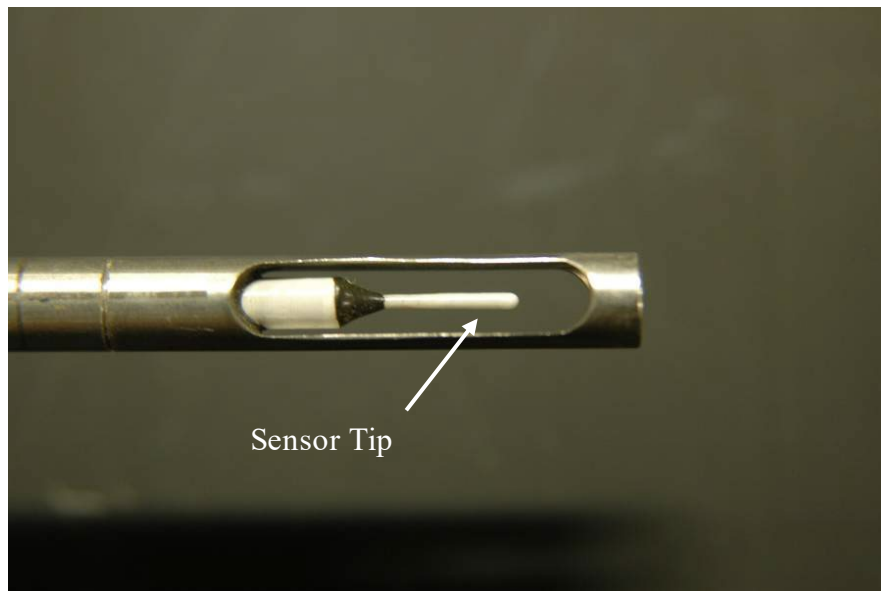

**Figure 10. Hot wire anemometer sensor**

2. If soot, debris, or damage is found, the test data will be reviewed for any irregularities with the data. If any irregularities are found, the data will not be used from the point at which the irregularities were first discovered.
3. If surface dirt is observed, the instrument shall be taken out of service until it has been cleaned according to manufacturer's instructions.
4. If visible damage is observed, the instrument is to be sent back to the manufacturer to be repaired. The unit must then be recalibrated, before it is put back into service.

## 6. Maintenance

- Except for the intermittent cleaning of the sensor probe, no routine maintenance required.
- If soot or debris are found, the component must be cleaned prior to testing.
- If the probe becomes coated with dust, *carefully* blow the dust away with clean air.
- If the probe is coated with sticky material, clean it with solvent which is compatible with epoxy, glass, and 304SS, and which will not leave a residue on the sensor.
- You may clean the sensor with water or alcohol (Ethanol) and an artist's brush.



ATF-LS-FRL Hot Wire Anemometer - Standard Operating Procedures	ID: 1595 Revision: 6
Authority: Technical Leader	Page: 13 of 13
Original maintained by Quality Programs; copies are uncontrolled.	

- If the unit needs to be repaired, send it back to manufacturer.

## 7. Calibration

- Hot wire anemometers are calibrated annually.



ATF-LS-FRL Laboratory Conditions - Standard Operating Procedures	ID: 1578 Revision: 4
Authority: Technical Leader	Page: 1 of 1
Original maintained by Quality Programs; copies are uncontrolled.	

## **I. Required Supplies**

- A. Vaisala PTU300 transmitter and PTU303 probe
- B. Ethernet cable

## **II. Start-Up and Pre-Test Procedures**

- A. Verify the Laboratory Conditions station is calibrated.
- B. Verify the Laboratory Conditions station is connected to the FireTOSS network using an Ethernet cable and that the unit is powered on.
- C. Verify that probe is free of obstructions or anything else that could interfere with the measurements.
- D. Verify the pressure port on the bottom of the unit is free from obstructions.
- E. In the FireTOSS experiment design program , select the appropriate Laboratory Conditions station that is near the area in which the test is being conducted.
- F. Verify the Laboratory Conditions station is working properly by looking at the data on the iFix Data Screen for Lab Conditions.

## **III. Experiment Procedures**

- A. Monitor the laboratory conditions data during the test.

## **IV. Post-Test and Shut-Down Procedure**

- A. Verify the data was collected properly and that there were no issues with the data.
- B. Laboratory Conditions station shall remain powered on and connected to the FireTOSS network.

## **V. Maintenance Procedures**

- A. Periodically check the probe and pressure port for obstructions and dirt.

## **VI. Calibration Procedures**

- A. Calibrate the entire unit (transmitter and probe) annually.



ATF-LS-FRL Sand Burner and Gas Cart - Standard Operating Procedures	ID: 1569 Revision: 6
Authority: Technical Leader	Page: 1 of 4
Original maintained by Quality Programs; copies are uncontrolled.	

## 1. Scope

This document contains the Standard Operating Procedure (SOP) for the Sand Burner and Gas Cart used at the Bureau of Alcohol, Tobacco, Firearms and Explosives (ATF) Fire Research Laboratory (FRL).

## 2. Supplies Required

### A. Burner(s)

- Sand Burner 1: 0.41 x 0.41 m (16 inch x 16 inch)
- Sand Burner 2: 0.41 x 0.41 m (16 inch x 16 inch)
- Sand Burner 3: 0.30 x 0.30 m (12 inch x 12 inch)
- Sand Burner 4: 0.20 x 0.20 m (8 inch x 8 inch)
- Sand Burner 5: 0.71 x 0.71 m (28 inch x 28 inch)

### B. Gas Cart(s)

- Gas Train A: 1000 SLPM
- Gas Train B: 1000 SLPM
- Gas Train C: 100 SLPM
- Gas Train D: 1000 SLPM
- Gas Train E: 3000 SLPM

### C. Stainless steel braided hose for natural gas transport

1. Diameter from main to gas cart: 3.8 cm (1½ inch)
2. Diameter from gas cart to burner:
  - 0.64 cm (¼ inch) for 100 SLPM (Gas Train C)
  - 2.54 cm (1 inch) for 1000 SLPM (Gas Train A, B, D)
  - 5 cm (2 inch) for 3000 SLPM (Gas Train E)

### D. 115 VAC electrical power – single extension cord

### E. FireTOSS connectivity – single Ethernet cable

### F. FireTOSS client computer

### G. Pilot Ignition Source: typically, metal tube (wand) connected to 20 lb. propane tank



ATF-LS-FRL Sand Burner and Gas Cart - Standard Operating Procedures	ID: 1569 Revision: 6
Authority: Technical Leader	Page: 2 of 4
Original maintained by Quality Programs; copies are uncontrolled.	

### 3. Initial Set Up

- A. Check calibration of mass flow controller(s) and data acquisition hardware. If out of calibration, see calibration technician.
- B. Connect appropriate stainless steel braided hose from fuel supply to cart and cart to burner.
- C. Perform a leak check on all connections.
- D. Connect cart to electrical power outlet using extension cord.
- E. Connect cart to FireTOSS port using ethernet cable.
- F. Make sure that mass flow controllers are NOT powered ON until ready for use. Make sure mass flow controller is UNPLUGGED. This is a precautionary measure to prevent burnout.

### 4. Start-Up and Pre-Test

- A. Select appropriate burner setup for test.
  - For 0-50 kW, use 100 SLPM gas train (Gas Train C).
  - For 0-500 kW, use single 1000 SLPM gas train (Gas Train A, B or D).
  - For 0-1300 kW, use 3000 SLPM gas train (Gas Train E).
  - For 0-1500 kW, use three 1000 SLPM gas trains (Gas Trains A, B and D).
  - For 0-2800 kW, use three 1000 SLPM gas trains (Gas Trains A, B and D) and the 3000 SLPM gas train (Gas Train E).
- B. Select the appropriate gas cart / burner pairing.
  - For the 1000 SLPM cart (A/B/D), use either the 0.30 m x 0.30 m burner or the 0.41 m x 0.41 m burner.
  - For the 100 SLPM cart (C), use the 0.20 m x 0.20 m burner.
  - For the 3000 SLPM cart (E), use the 0.71 m x 0.71 m burner.
- C. Position burner(s) where needed.
- D. Set up and ignite propane pilot for Burners. Do NOT turn burner gas supply ON until pilot light has been ignited.
- E. Plug power cord into mass flow controller.
- F. Verify that mass flow controller set point is 0.0 SLPM.
- G. Turn natural gas ON.
  1. In mezzanine, turn main gas valve to ON position, turn the compressed air valve to ON position, and turn control switch to manual position.



ATF-LS-FRL Sand Burner and Gas Cart - Standard Operating Procedures	ID: 1569 Revision: 6
Authority: Technical Leader	Page: 3 of 4
Original maintained by Quality Programs; copies are uncontrolled.	

2. Pull out emergency shutoff “mushroom” button located on wall of burn room.
  3. Turn wall main valve(s) to ON position.
  4. Turn both valves on cart(s) to ON position.
- H. Check gas pressures to cart(s) to verify adequate gas supply.

## 5. Experiment Procedures

### A. Burner Control Through iFix

1. Launch iFix.
2. Select “Burner Control” button at top of screen.
3. Select the gas cart(s) to be used.
4. Select the fuel to be used (generally natural gas).
5. Verify combustion calorimeter warning light is green.
6. Select the program to run.
  - a) Manual – User control of flow rate controlled with input box
  - b) 5 Point Cal – Burner follows a preset series of five flowrates
  - c) 8 Point Cal - Burner follows a preset series of eight flowrates
  - d) Custom – Runs a Prescribed HRR Curve From a text file
    - 1) Text file must be located in the C:\ directory and have the name “BurnerControlX” where X is the gas train name (A,B,C,D,E)
    - 2) In text file, input the following: HRR,Duration.
      - i. “HRR” is the desired Heat Release Rate of the specific step.
      - ii. “Duration” is the time duration of the specific step.
      - iii. Each line of the text file is interpreted as a “step” by the burner program. A correct text file should be formatted as such:
        1. HRR,Duration
        2. HRR,Duration
        3. HRR,Duration
        4. etc.
      - iv. Upon the completion of the final step (line of the text file), the Burner Control Program will set all active Mass Flow Controller set points to zero (0).



ATF-LS-FRL Sand Burner and Gas Cart - Standard Operating Procedures	ID: 1569 Revision: 6
Authority: Technical Leader	Page: 4 of 4
Original maintained by Quality Programs; copies are uncontrolled.	

7. Start Program Selected
  - a) If using 5 Point Cal, 8 Point Cal, or Custom, press “Gas ON” button.
  - b) If using Manual program, enter starting value in input box and press “Enter” key. Subsequent values are also entered using this method.
8. Press “Gas OFF” button when finished test.

**B. During Test**

1. Monitor pressure at cart to ensure adequate fuel supply
2. Monitor mass flow controller set point to verify desired flow

**6. Shut Down and Post-Test**

**A. Turn OFF natural gas.**

1. Turn both valves on cart to OFF position.
2. Turn wall main valve to OFF position.
3. Push In emergency shutoff “mushroom” button located on wall of burn room.
4. In mezzanine, turn main gas valve to OFF position, turn the compressed air valve to OFF position and turn control switch to OFF position.

**B. Power OFF mass flow controllers if no more tests are being performed by unplugging power cord from mass flow controller**

**7. Maintenance**

- A. Periodically check for leaks at connections
- B. Power OFF mass flow controllers when not in use

**8. Calibration**

- Mass flow controller shall be calibrated annually.



ATF-LS-FRL Sartorius Scale-150 kg-Standard Operating Procedure	ID: 4248 Revision: 4
Authority: Technical Leader	Page: 1 of 4
Original maintained by Quality Programs; copies are uncontrolled.	

## I. Required Supplies

- a. Indicator Unit
  - i. Sartorius Combics 2 Model CAIS2-U, Asset # 99000789
  - ii. Power: 120 VAC power cord connected to indicator.
  - iii. Communication to Platform: Sartorius cable
  - iv. DAQ Communication: network cable connected to indicator.
- b. Weighing Platform 1 (WP1)
  - i. Sartorius Model CAPP1U-250GG-LU
  - ii. Equipped with 1 Model 011253A (150 kg/300 lb) capacity load cell
    1. The cable from the load cell runs into a junction box and is then sent to the indicator.
- c. If recording scale data electronically,
  - i. Data acquisition (DAQ) setup: connected network cable from indicator to FireTOSS network jack.
- d. If not recording scale data electronically,
  - i. Synchronized camera and/or an appropriate datasheet

## II. Setup Procedures

- a. Ensure weighing device is calibrated
- b. Position the weighing platform
  - i. Move the weighing device to the location where measurements are to be taken.
  - ii. Level the device on the surface of the location. Perform this action until both the horizontal and vertical axes are level.
  - iii. Maintain an environmental temperature between (-10°C and +40°C). Excessive temperatures will invalidate results and may cause permanent damage to the loads cells. Perform a functional verification according to the instructions in the Function Verification Procedures section if the weighing device is subjected to intolerable temperatures at any time.



ATF-LS-FRL Sartorius Scale-150 kg-Standard Operating Procedure	ID: 4248 Revision: 4
Authority: Technical Leader	Page: 2 of 4
Original maintained by Quality Programs; copies are uncontrolled.	

- c. Connecting to the DAQ. Skip this step if not using the DAQ.
  - i. Connect the network cable from the indicator to a FireTOSS jack.
  - ii. Data Channel Tag: WD\_0150KG\_99000789\_WEIGHT
- d. Connecting the Instrument
  - i. Connect the power cable from the indicator to a 120 VAC outlet.
- e. Using the Indicator Unit
  - i. Press the power button on the indicator.
  - ii. Check that the indicator is displaying the weight in kilograms.
  - iii. To ensure accurate results, the indicator must warm up for 30 minutes before operation. Only after this time will the indicator have reached the required operating temperature.
  - iv. Press the “Zero” button to zero the indicator without any load on the weighing platform.
  - v. If adding an additional frame and or heat protection on top of the platform, add that and then press the “Tare” button to tare the scale.
    - \* INF 09 Message - This means tarring is not possible when the gross weight is less than zero. Action: Remove anything that is on the platform. Press the “Zero” button to zero the indicator. If using a frame and or heat protection then add that back to the platform. Then press the “Tare” button to tare the indicator. The indicator should now display, “0.00 kg”.

### III. Experiment Procedures

- a. Perform a functional verification according to the instructions provided in the Functional Verification Procedures section.
- b. Activating DAQ Recording. Skip this step if not connected to the DAQ.
  - i. The output of the indicator is automatically saved in the DAQ, once the indicator has power and is connected to the FireTOSS network. Check in iFix.
  - ii. Check that computer icon is flashing on the indicator screen. This shows that there is communication.
- c. Check that the indicator is displaying the weight in kilograms.
- d. Check that the indicator is displaying, “0.00 kg”, with the platform by itself or any additional frame or heat protection that is not to be measured in the experiment.



ATF-LS-FRL Sartorius Scale-150 kg-Standard Operating Procedure	ID: 4248 Revision: 4
Authority: Technical Leader	Page: 3 of 4
Original maintained by Quality Programs; copies are uncontrolled.	

- e. Weigh the object
  - i. Place object to be weighed on the weighing platform in a manner such that the center of mass of the object is as close the center of the weighing platform as possible.
  - ii. Allow measurements to stabilize. The stabilization time for the indicator unit requires a minimum of 3 seconds.
  - iii. If the scale is not connected to the DAQ, record manually using a camera and/or the appropriate datasheet.
  - iv. **The maximum measurement capacity for the weighing platform is 150 kg (300 lb). Results of 150 kg (300 lb) or more are invalid and a larger capacity weighing device is needed.**
  - v. **The maximum overload capacity for the load cells is as follows:**
    - Corner: 150 kg (300 lb)**
    - Side: 200 kg (440 lb)**
    - Center 300 kg (660 lb)**

**If subject to a load greater than this, remove the weighing device from service and notify the calibration technician to arrange for a calibration of the weighing device. Repair or replace components as necessary.**
- f. If performing additional measurements, tare the indicator unit prior to each test.
- g. During testing, if the weighing platform is repositioned, the weighing platform must be leveled and functionally verified prior to continuing tests.

#### IV. Shut-Down and Maintenance Procedures

- a. If a test series is complete, perform a functional verification according to the instructions in the Functional Verification Procedures section.
- b. If necessary, wipe off any stains or spills on the weighing device.
- c. Inspect the weighing device for any significant damage. If necessary, notify the calibration technician of the damage to arrange for calibration to confirm the functionality of the weighing device and the reliability of future test results.
- d. Power down the indicator unit and unplug it and the Ethernet cables. Then store the weighing device in an area where it will not be subjected to heavy loads or to extreme temperatures. **The load cells can be permanently fatigued regardless of the device being on or off.**



ATF-LS-FRL Sartorius Scale-150 kg-Standard Operating Procedure	ID: 4248 Revision: 4
Authority: Technical Leader	Page: 4 of 4
Original maintained by Quality Programs; copies are uncontrolled.	

## V. Functional Verification Procedure

- a. Setup up the device according to the instructions in the Setup Procedures section.
- b. Zero the weighing device
- c. Functionally verify the indicator display:
  - i. Apply a load of a known magnitude to the center of the weighing platform and observe the measurements in the DAQ system and on the indicator unit for 5 minutes.
    1. If there is no significant measurement inaccuracy or measurement creep, the weighing device is functionally verified.
    2. If the indicator displays correct readings and the DAQ system displays intolerable readings, remove the weighing device from service and notify the calibration technician to arrange for a calibration of the weighing device. Repair or replace components as necessary.
    3. If the measurement readings are intolerable on the indicator and in the DAQ system, remove the weighing device from service and notify the calibration technician to arrange for a calibration of the weighing device. Repair or replace components as necessary.
  - ii. If functionally verified, remove the applied load and zero the indicator unit prior to taking the next measurement.



ATF-LS-FRL Sartorius Scale-30 kg-Standard Operating Procedure	ID: 4247 Revision: 4
Authority: Technical Leader	Page: 1 of 4
Original maintained by Quality Programs; copies are uncontrolled.	

## I. Required Supplies

- a. Indicator Unit
  - i. Sartorius Combics 2 Model CAISL2-U, Asset # 99000791
  - ii. Power: 120 VAC power cord connected to indicator.
  - iii. Communication to Platform: Sartorius cable
  - iv. DAQ Communication: network cable connected to indicator.
- b. Weighing Platform 1 (WP1)
  - i. Sartorius Model CAPP1U-50DD-LU
  - ii. Equipped with one 03167124 (30 kg/60 lb) capacity load cell
    - 1. The cable from the load cell run to a junction box and is then sent to the indicator.
- c. If recording scale data electronically,
  - i. Data acquisition (DAQ) setup: connected network cable from indicator to FireTOSS network jack.
- d. If not recording scale data electronically,
  - i. Synchronized camera and/or an appropriate datasheet

## II. Setup Procedures

- a. Ensure weighing device is calibrated
- b. Position the weighing platform
  - i. Move the weighing device to the location where measurements are to be taken.
  - ii. Level the device on the surface of the location. Perform this action until both the horizontal and vertical axes are level.
  - iii. Maintain an environmental temperature between (-10°C and +40°C). Excessive temperatures will invalidate results and may cause permanent damage to the loads cells. Perform a functional verification according to the instructions in the Function Verification Procedures section if the weighing device is subjected to intolerable temperatures at any time.
- c. Connecting to the DAQ. Skip this step if not using the DAQ.
  - i. Connect the network cable from the indicator to a FireTOSS jack.
  - ii. Data Channel Tag: WD\_0030KG\_99000791\_WEIGHT



ATF-LS-FRL Sartorius Scale-30 kg-Standard Operating Procedure	ID: 4247 Revision: 4
Authority: Technical Leader	Page: 2 of 4
Original maintained by Quality Programs; copies are uncontrolled.	

- d. Connecting the Instrument
  - i. Connect the power cable from the indicator to a 120 VAC outlet.
- e. Using the Indicator Unit
  - i. Press the power button on the indicator.
  - ii. Check that the indicator is displaying the weight in kilograms.
  - iii. To ensure accurate results, the indicator must warm up for 30 minutes before operation. Only after this time will the indicator have reached the required operating temperature.
  - iv. Press the “Zero” button to zero the indicator without any load on the weighing platform.
  - v. If adding an additional frame and or heat protection on top of the platform, add that and then press the “Tare” button to tare the scale.
    - \* INF 09 Message - This means tarring is not possible when the gross weight is less than zero. Action: Remove anything that is on the platform. Press the “Zero” button to zero the indicator. If using a frame and or heat protection then add that back to the platform. Then press the “Tare” button to tare the indicator. The indicator should now display, “0.00 kg”.

### III. Experiment Procedures

- a. Perform a functional verification according to the instructions provided in the Functional Verification Procedures section.
- b. Activating DAQ Recording. Skip this step if not connected to the DAQ.
  - i. The output of the indicator is automatically saved in the DAQ, once the indicator has power and is connected to the FireTOSS network. Check in iFix.
  - ii. Check that computer icon is flashing on the indicator screen. This shows that there is communication.
- c. Check that the indicator is displaying the weight in kilograms.
- d. Check that the indicator is displaying, “0.00 kg”, with the platform by itself or any additional frame or heat protection that is not to be measured in the experiment.



ATF-LS-FRL Sartorius Scale-30 kg-Standard Operating Procedure	ID: 4247 Revision: 4
Authority: Technical Leader	Page: 3 of 4
Original maintained by Quality Programs; copies are uncontrolled.	

- e. Weigh the object
  - i. Place object to be weighed on the weighing platform in a manner such that the center of mass of the object is as close the center of the weighing platform as possible.
  - ii. Allow measurements to stabilize. The stabilization time for the indicator unit requires a minimum of 3 seconds.
  - iii. If the scale is not connected to the DAQ, record manually using a camera and/or the appropriate datasheet.
  - iv. The maximum measurement capacity for the weighing platform is 30 kg (60 lb). Results of 30 kg (60 lb) or more are invalid and a larger capacity weighing device is needed.
  - v. The maximum overload capacity for the load cells is as follows:
    - Corner: 45 kg (100 lb)
    - Side: 85 kg (190 lb)
    - Center 130 kg (290 lb)If subject to a load greater than this, remove the weighing device from service and notify the calibration technician to arrange for a calibration of the weighing device. Repair or replace components as necessary.
- f. If performing additional measurements, tare the indicator unit prior to each test.
- g. During testing, if the weighing platform is repositioned, the weighing platform must be leveled and functionally verified prior to continuing tests.

#### IV. Shut Down and Maintenance Procedures

- a. If a test series is complete, perform a functional verification according to the instructions in the Functional Verification Procedures section.
- b. If necessary, wipe off any stains or spills on the weighing device.
- c. Inspect the weighing device for any significant damage. If necessary, notify the calibration technician of the damage to arrange for calibration to confirm the functionality of the weighing device and the reliability of future test results.
- d. Power down the indicator unit and unplug it and the Ethernet cable. Then store the weighing device in an area where it will not be subjected to heavy loads or to extreme temperatures. **The load cells can be permanently fatigued regardless of the device being on or off.**



ATF-LS-FRL Sartorius Scale-30 kg-Standard Operating Procedure	ID: 4247 Revision: 4
Authority: Technical Leader	Page: 4 of 4
Original maintained by Quality Programs; copies are uncontrolled.	

## V. Functional Verification Procedure

- a. Setup up the device according to the instructions in the Setup Procedures section.
- b. Zero the weighing device
- c. Functionally verify the indicator display:
  - i. Apply a load of a known magnitude to the center of the weighing platform and observe the measurements in the DAQ system and on the indicator unit for 5 minutes.
    1. If there is no significant measurement inaccuracy or measurement creep, the weighing device is functionally verified.
    2. If the indicator displays correct readings and the DAQ system displays intolerable readings, remove the weighing device from service and notify the calibration technician to arrange for a calibration of the weighing device. Repair or replace components as necessary.
    3. If the measurement readings are intolerable on the indicator and in the DAQ system, remove the weighing device from service and notify the calibration technician to arrange for a calibration of the weighing device. Repair or replace components as necessary.
  - ii. If functionally verified, remove the applied load and zero the indicator unit prior to taking the next measurement.



ATF-LS-FRL Sartorius Scale-450kg - Standard Operating Procedures	ID: 2139 Revision: 6
Authority: Technical Leader	Page: 1 of 4
Original maintained by Quality Programs; copies are uncontrolled.	

## I. Required Supplies

- a. Indicator Unit
  - i. Sartorius Combics 3 Model CIS3-U, Asset # 99000695
  - ii. Power: 120 VAC power cord connected to indicator.
  - iii. Communication: Sartorius cable connected to indicator.
  - iv. DAQ Communication: network cable connected to indicator.
- b. Weighing Platform 1 (WP1)
  - i. Sartorius Model CAPP4U-1000KK-LU
  - ii. Equipped with four GWT-011462 500 lb capacity load cells
    1. The cables from the load cells run to a junction box and output as serial data to the indicator with a Sartorius PR6130 Cable.
- c. If recording scale data electronically,
  - i. Data acquisition (DAQ) setup: connected network cable from indicator to FireTOSS network jack.
- d. If not recording scale data electronically,
  - i. Synchronized camera and/or an appropriate datasheet

## II. Setup Procedures

- a. Ensure weighing device is calibrated
- b. Position the weighing platform
  - i. Move the weighing device to the location where measurements are to be taken.
  - ii. Level the device on the surface of the location. Perform this action until both the horizontal and vertical axes are level. The level on the platform is broken. Use a 3 foot or longer level to check the platform.
  - iii. Maintain an environmental temperature between (-10°C and +40°C). Excessive temperatures will invalidate results and may cause permanent damage to the loads cells. Perform a functional verification according to the instructions in the Function Verification Procedures section if the weighing device is subjected to intolerable temperatures at any time.



ATF-LS-FRL Sartorius Scale-450kg- Standard Operating Procedures	ID: 2139 Revision: 6
Authority: Technical Leader	Page: 2 of 4
Original maintained by Quality Programs; copies are uncontrolled.	

- c. Connecting the Instrument
  - i. Connect the network cable from the indicator to a FireTOSS jack.
  - ii. Data Channel Tag: WD\_0450KG\_99000695\_WEIGHT
- d. Connecting to the Instrument.
  - i. Connect the power cable from the indicator to a 120 VAC outlet
- e. Using the Indicator Unit
  - i. Press the power button on the indicator.
  - ii. Check that the indicator is displaying the weight in kilograms.
  - iii. To ensure accurate results, the indicator must warm up for 30 minutes before operation. Only after this time will the indicator have reached the required operating temperature.
  - iv. Press the “Zero” button to zero the indicator without any load on the weighing platform.
  - v. If adding an additional frame and or heat protection on top of the platform, add that and then press the “Tare” button to tare the scale.
    - \* INF 09 Message - This means tarring is not possible when the gross weight is less than zero. Action: Remove anything that is on the platform. Press the “Zero” button to zero the indicator. If using a frame and or heat protection then add that back to the platform. Then press the “Tare” button to tare the indicator. The indicator should now display, “0.00 kg”.

### III. Experiment Procedures

- a. Perform a functional verification according to the instructions provided in the Functional Verification Procedures section.
- b. If necessary, return to main weighing screen by pressing the button below the “←” on the screen.
- c. Activating DAQ Recording. Skip this step if not connected to the DAQ.
  - i. The output of the indicator is automatically saved in the DAQ, once connected to the FireTOSS network and the indicator has power.
  - ii. Check that computer icon is flashing on the indicator screen. This shows that there is communication.
- d. Check that the indicator is displaying the weight in kilograms.



ATF-LS-FRL Sartorius Scale-450kg - Standard Operating Procedures	ID: 2139 Revision: 6
Authority: Technical Leader	Page: 3 of 4
Original maintained by Quality Programs; copies are uncontrolled.	

- e. Check that the indicator is displaying, “0.00 kg”, with the platform by itself or any additional frame or heat protection that is not to be measured in the experiment.
- f. Weigh the object
  - i. Place object to be weighed on the weighing platform in a manner such that the center of mass of the object is as close the center of the weighing platform as possible.
  - ii. Allow measurements to stabilize. The stabilization time for the indicator unit requires a minimum of 3 seconds.
  - iii. If the scale is not connected to the DAQ, record manually using a camera and/or the appropriate datasheet.
  - iv. The maximum measurement capacity for the weighing platform is 1500 lb / 600 kg. Results of 1500 lb / 600 kg or more are invalid and a larger capacity weighing device is needed.
  - v. The maximum overload capacity for the load cells is as follows:  
Corner: 3300 lb / 1500 kg  
Side: 6600 lb / 3000 kg  
Center 9900 lb / 4500 kg  
  
If subject to a load greater than this, remove the weighing device from service and notify the calibration technician to arrange for a calibration of the weighing device. Repair or replace components as necessary.
- g. If performing additional measurements, tare the indicator unit prior to each test.
- h. During testing, if the weighing platform is repositioned, the weighing platform must be leveled and functionally verified prior to continuing tests.

#### **IV. Shut-Down and Maintenance Procedures**

- a. If a test series is complete, perform a functional verification according to the instructions in the Functional Verification Procedures section.
- b. If necessary, wipe off any stains or spills on the weighing device.
- c. Inspect the weighing device for any significant damage. If necessary, notify the calibration technician of the damage to arrange for calibration to confirm the functionality of the weighing device and the reliability of future test results.
- d. Power down the indicator unit and unplug WP1 and Ethernet cables. Then store the weighing device in an area where it will not be subjected to heavy loads or to



ATF-LS-FRL Sartorius Scale-450kg - Standard Operating Procedures	ID: 2139 Revision: 6
Authority: Technical Leader	Page: 4 of 4
Original maintained by Quality Programs; copies are uncontrolled.	

extreme temperatures. **The load cells can be permanently fatigued regardless of the device being on or off.**

## V. Functional Verification Procedure

- a. Setup up the device according to the instructions in the Setup Procedures section.
- b. Zero the weighing device
- c. Functionally verify the indicator display:
  - i. Apply a load of a known magnitude to the center of the weighing platform and observe the measurements in the DAQ system and on the indicator unit for 5 minutes.
    1. If there is no significant measurement inaccuracy or measurement creep, the weighing device is functionally verified.
    2. If the indicator displays correct readings and the DAQ system displays intolerable readings, remove the weighing device from service and notify the calibration technician to arrange for a calibration of the weighing device. Repair or replace components as necessary.
    3. If the measurement readings are intolerable on the indicator and in the DAQ system, remove the weighing device from service and notify the calibration technician to arrange for a calibration of the weighing device. Repair or replace components as necessary.
  - ii. If functionally verified, remove the applied load and zero the indicator unit prior to taking the next measurement.



## 1. Scope

This document contains the Standard Operating Procedure (SOP) for the Servomex 4100 gas analysis rack. The gas analysis rack consists of a Servomex 4100 gas analyzer and various other components (sample pump, gas filters, etc.) that are used to measure the concentrations of Oxygen ( $O_2$ ), Carbon Monoxide (CO), and Carbon Dioxide ( $CO_2$ ). The Servomex gas analysis rack is primarily used with the Fire Product Collectors, but can also be used as a standalone point source gas measuring system. Figure 1 shows the overall gas analysis rack setup.



Figure 1. Servomex 4100 Gas Analysis Rack

## 2. Required Supplies

### A. Calibration Gases

1. CO/ $CO_2$ /Nitrogen ( $N_2$ ) span gas (0.8% CO / 8.0%  $CO_2$  /  $N_2$  Balance)
2.  $N_2$  Zero Gas (100%)

### B. Desiccant

### C. Gas bladder (only required if measuring delay times of gases)



ATF-LS-FRL Servomex 4100 Gas Analysis Rack - Standard Operating Procedures	ID: 1583 Revision: 5
Authority: Technical Leader	Page: 2 of 6
Original maintained by Quality Programs; copies are uncontrolled.	

### 3. Initial Setup

- A. Verify that all instrumentation is connected to the data acquisition (DAQ) system.
- B. Verify that all instrumentation and DAQ systems are powered.
- C. Clean out gas sample lines using compressed air. Always blow compressed air away from analyzer inlet. After cleaning, verify that all tubing has been reconnected.
- D. Check calibration status of all instrumentation.
  - 1. Gas analyzers (yearly in-house verification required)
  - 2. Span gases (replaced yearly)
- E. Verify there is sufficient calibration gases to run the calibration.

### 4. Start-Up and Pre-Test

- A. Verify that power is being supplied to rack and that the analyzer power button is in the ON setting (see Figure 2). The red light within the button should be illuminated and the analyzer display screen should be on.

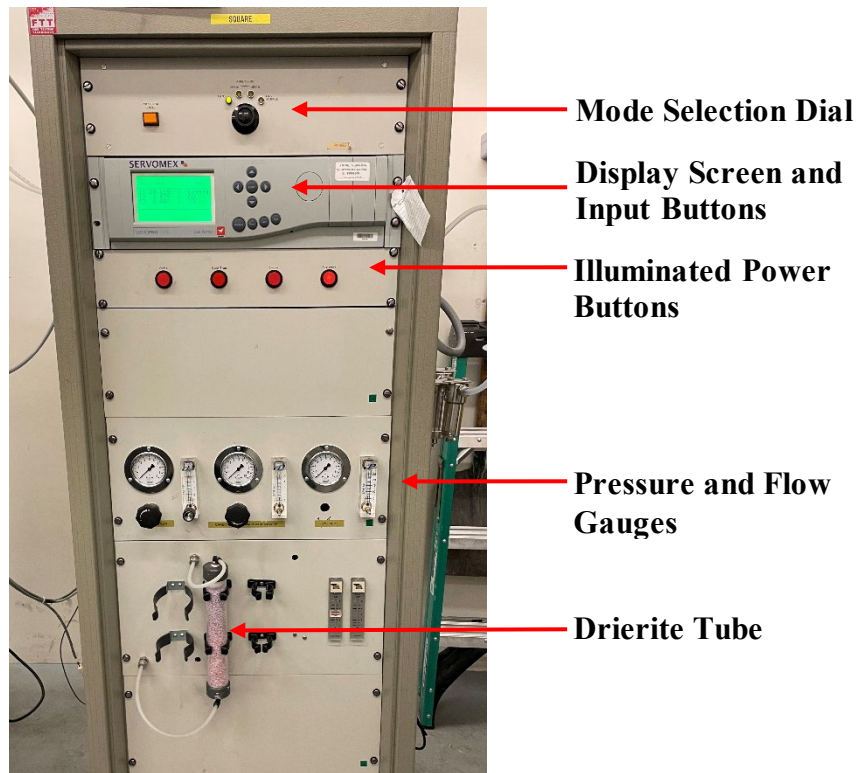
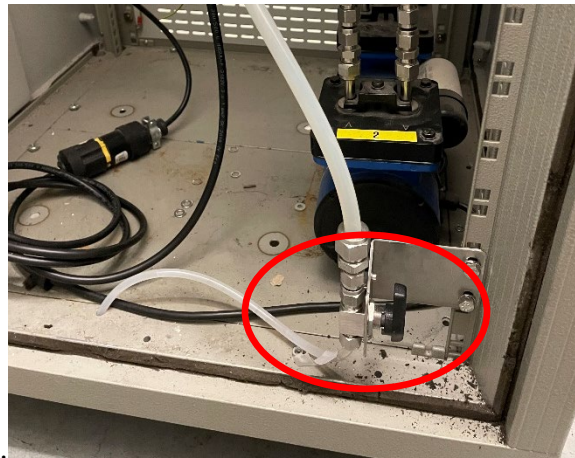

Figure 2. Analyzer Rack



ATF-LS-FRL Servomex 4100 Gas Analysis Rack - Standard Operating Procedures	ID: 1583 Revision: 5
Authority: Technical Leader	Page: 3 of 6
Original maintained by Quality Programs; copies are uncontrolled.	

- B. Drain cold trap. The cold trap drain is located inside the back of the rack at the very bottom (see Figure 3). Make sure that valve is closed after draining the water. The black handle on the valve will be perpendicular to the valve when the drain is in the closed position.



**Figure 3: Cold Trap Drain Valve**

- C. Turn cold trap ON. Make sure button is illuminated.
- D. Check all filters and replace if necessary.
- E. Check desiccant and replace if necessary. If using Drierite, it should be blue when ready to use and pink when it needs to be replaced.
- F. Make sure Mode selection dial is turned to “AUTO”.
- G. Turn sample pump on. Make sure button is illuminated.
- H. Gas sample pressures should be 5 psi for O<sub>2</sub> and CO/CO<sub>2</sub>, and 7 psi for the Bypass. The O<sub>2</sub> flow rate shall be set to 3 LPM and the CO/CO<sub>2</sub> flow 3.5-4 LPM.
- I. Allow pump to run for approximately 15 minutes.
- J. Verify that N<sub>2</sub> and CO/CO<sub>2</sub> calibration gas cylinders are turned on and at a pressure of at least 15 psi.
- K. Verify the gas cylinders are supplying gas to the gas analysis rack.
1. Turn the Mode selection dial to the Zero position and verify that the pressure in the O<sub>2</sub> line and CO/CO<sub>2</sub> line are reading 5 psi.
  2. Turn the Mode selection dial to the calibration gas and verify that the CO/CO<sub>2</sub> pressure is reading 5 psi.



ATF-LS-FRL Servomex 4100 Gas Analysis Rack - Standard Operating Procedures	ID: 1583 Revision: 5
Authority: Technical Leader	Page: 4 of 6
Original maintained by Quality Programs; copies are uncontrolled.	

3. If an autocal is performed and either the pump, nitrogen gas, or the CO/CO<sub>2</sub> span gas are not supplying gas to the gas analyzer, then a warning will appear on the gas analyzer's screen displaying a Lo Cal or Hi Cal error.
- L. Verify that the analyzer does not have any error messages on the display screen.
- M. Perform a calibration.
1. Press menu button.
  2. Select "Calibrate" from on-screen menu and press enter button.
  3. Enter password by using the up/down arrow keys (↕) to adjust the numbers and the right and left arrow keys (←→) to change which number is being adjusted. [REDACTED]
  4. Select "AutoCal" and press enter.
  5. Select "One Cycle" and press enter.
  6. Select "Cal Group 1" and press enter.
  7. The AutoCal icon should appear on the screen.
  8. The Autocal process should complete after approximately 15 minutes.
  9. The analyzer should display these approximate values following a successful calibration:
    - O<sub>2</sub>: 20.95%
    - CO: 0.00%
    - CO<sub>2</sub>: 0.04%
  10. If values displayed by analyzer do not match the expected values, check all settings and calibration gases, and perform a second calibration. If, after a second calibration, the values are still different from the expected values, troubleshoot and if no issues are found take analyzer out of service.
- N. After a successful calibration, turn off calibration gas cylinders.
- O. The analyzer is now ready to be used.

## 5. Measure Delay Times

### A. Fire Product Collector Use

- The delay times of the gases were determined during the commissioning of each FPC and are stored in the FireTOSS database for each FPC.
- The delay times may need to be verified if inconsistencies in the data are observed during a routine FPC C-factor test.



## B. Stand-Alone Use

- Delay times must be calculated using the following procedure.
  - a. Fill gas bladder with the CO/CO<sub>2</sub> span gas.
  - b. With DAQ running, attach bladder valve to end of sample line.
  - c. The time from when the bladder valve is turned on to the initial response by the analyzer is the delay time. Repeat 2-3 times and then use the average of the delay times.

## 6. Experiment Procedures

- A. Monitor data to ensure that no anomalies occur.
- B. If all gas measurements drop drastically during a test, then the most likely issue is that the sample line or filter is clogged, and insufficient gas is reaching the analyzer.
  1. The pump to the gas analyzer should be turned off and an event shall be added to the experiment noting that the pump to the gas analyzer was turned off.
  2. If the issue is resolved (e.g., filter replaced), then an event shall be added to the experiment noting when the pump to the gas analyzer was turned on.

## 7. Shut Down and Post-Test

- A. After the test has been completed power off cold trap and sample pump on analyzer rack.
- B. If any problems arose during testing (i.e., clogged sample line or filters) perform necessary maintenance.

## 8. Maintenance Procedures

- A. Blow out sample lines using compressed air prior to each test series or as needed.
- B. Change paper filters located in metal filter housing on side of rack as needed. Clean or change sintered metal filter as needed. These filters keep soot and debris out of the pump and analyzers.
- C. Change the desiccant when needed. If using Drierite, it should be blue in color when ready to use and pink when it needs to be replaced. If the desiccant is not changed frequently, excess water could enter the pump or gas analyzer.



ATF-LS-FRL Servomex 4100 Gas Analysis Rack - Standard Operating Procedures	ID: 1583 Revision: 5
Authority: Technical Leader	Page: 6 of 6
Original maintained by Quality Programs; copies are uncontrolled.	

## 9. Calibration

- A. Perform auto-calibration prior to first test of each day or as needed/desired.
- B. Analyzers shall be functionally verified in-house annually. The ATF procedure for functional verification meets or exceeds the testing protocol for verification from Fire Testing Technology (FTT). Analyzers that do not pass in-house verification will be sent to FTT for additional verification and maintenance. Records of verifications are kept by the calibration technician.



ATF-LS-FRL Servomex Gas Analyzer Functional Verification - Standard Operating Procedures	ID: 8000 Revision: 3
Authority: Technical Leader	Page: 1 of 13
Original maintained by Quality Programs; copies are uncontrolled.	

## 1. Scope

This document contains the Standard Operating Procedure (SOP) for the Functional Verification of Servomex Analyzers at the ATF Fire Research Laboratory (FRL). Functional verification consists of two separate processes: the adjustment of the CO and CO<sub>2</sub> transducer differential signal and the analyzer drift tests.

## 2. Required Supplies

- A. Servomex Gas Analyzer – Model 4100C
- B. Gas Analyzer Exercise Rack
- C. Computer connected to FireTOSS/iFix Network
- D. Calibration Gases
  - Nitrogen (Zero Grade)
  - CO/CO<sub>2</sub> Span gas ~ 0.8% CO, 8% CO<sub>2</sub>, Balance N<sub>2</sub> (Primary Standard)
  - O<sub>2</sub> Span gas ~ 21% O<sub>2</sub>, Balance N<sub>2</sub> (Primary Standard)
- E. Digital Multimeter with a display that has a minimum of 3 decimal places
- F. Screw Drivers
  - Flat Head
  - Philips Head
- G. 9/32 inch Nut driver
- H. Needle nose pliers

## 3. Start Up Procedures

1. Place the gas analyzer in a location where there is sufficient space to remove the top cover and reach the transducers inside the chassis.
  - A gas analyzer exercise rack is located in the equipment shed (P-S4) in the Mezzanine area. Each slot on the gas analyzer exercise rack is equipped with a sliding shelf, which will allow the user to remove the top of the analyzer. If the analyzer being verified is already mounted on one of the shelves, ensure the analyzer has been powered on for at least 15 minutes, the gas lines are securely tightened, and proceed to the experiment procedures section.
2. Plug the gas analyzer into an electrical outlet and turn on the instrument.



ATF-LS-FRL Servomex Gas Analyzer Functional Verification - Standard Operating Procedures	ID: 8000 Revision: 3
Authority: Technical Leader	Page: 2 of 13
Original maintained by Quality Programs; copies are uncontrolled.	

3. The gas analyzers will take approximately 15 minutes to warm up. The analyzer will display a warm up signal on the main display screen during this time. Upon completion of warm up period, the signal will no longer be displayed on the screen.

*Do not proceed to the Experimental Procedures until the instrument has completely warmed up.*

#### 4. Experiment Procedures

##### A. Cell Voltage/Differential Signal Adjustment Procedure

The following describes how to readjust the offset found on the zero signal of the CO<sub>2</sub> transducer and CO transducer. For additional references, including detailed images of the inner components of the Servomex analyzer, refer to Fire Testing and Technology (FTT) documentation on the adjustment of cell voltages [1, 2]. Appendix A also provides photographs showing the internal components of the gas analyzer.

1. Connect the nitrogen gas line to the *Sample Inlet 2* port on the back of the gas analyzer.
2. Connect an exhaust line to the *Sample Outlet 2* port on the back of the analyzer. The exhaust line can be from either a gas analyzer rack or the gas exercise rack.
3. Flow nitrogen gas through the CO/CO<sub>2</sub> cells at 5 psi for at least 15 minutes.
4. With the nitrogen gas flowing, turn off the gas analyzer and unplug the power cord. Power is removed from the instrument to prevent any static discharge to the gas analyzer's internal electronics during the verification process, which could damage the electrical components.

*Prior to contacting any electronics within the analyzer, discharge any static from your hand to the metal analyzer chassis.*

5. Remove the top cover of the gas analyzer.
6. Locate the metal U-shaped mounting bracket that contains both the CO<sub>2</sub>/CO transducer boards. The mounting bracket is located behind the front panel on the right side of the chassis (Figure A1).
7. Remove the mounting bracket with the transducer boards still attached.
  - a) Partly unscrew the four (4) nuts holding the mounting bracket to the bottom of the chassis.
  - b) Slide the mounting bracket to the left to remove the bracket. You may need to move tubing and ribbon cables out of the way to lift the mounting bracket high enough to access the transducer boards. If the ribbon cable is



ATF-LS-FRL Servomex Gas Analyzer Functional Verification - Standard Operating Procedures	ID: 8000 Revision: 3
Authority: Technical Leader	Page: 3 of 13
Original maintained by Quality Programs; copies are uncontrolled.	

disconnected while moving the mounting bracket, be sure to reconnect the cable prior to turning on the analyzer.

8. Locate the CO<sub>2</sub> transducer board on the mounting bracket. The CO<sub>2</sub> transducer board is located closest to the front panel (Figure A1).
9. Connect the leads of the multimeter to TP7 (ground) and TP 2 (load) on the CO<sub>2</sub> transducer board. The TP 7 is typically positioned on the top left hand side of the printed circuit board and TP 2 is on the same side towards the bottom of the board (Figure A2). Verify the connection points prior to connecting the multimeter (they are labeled on the board), as the transducer board is not always oriented the same way for all analyzers.
10. Turn on the multimeter and set it to DC voltage.
11. Plug in the power cord back into the gas analyzer and turn on the power. *Wait for the gas analyzer to finish warming up before taking any voltage readings.*
12. While the gas analyzer is warming up, open the “*Functional Verification Report Template - Cell Voltage and Diff Sig.pdf*”, which is located in the CAIG folder on the Occoquan share drive (Occoquan\Calibration Lab\Gas Analyzer\Functional Verification\CO-CO<sub>2</sub> Cell Voltage and Diff Sig\).
13. After the gas analyzer has finished warming up, check the Differential Signal for the CO<sub>2</sub> cell (*CO<sub>2</sub> DIF SIG*) on the gas analyzer screen.
  - a) Push the *Menu* button on the gas analyzer and select *Diagnostics* from the *Setup* menu.

SETUP→DISPLAY→DIAGNOSTICS

- b) Press the up arrow on the gas analyzer until *I2 CO<sub>2</sub> DIF SIG* is displayed on the screen.
14. Record the CO<sub>2</sub> DIF SIG value displayed on the gas analyzer in the “As Found DIF SIG” box on the *Functional Verification Report* sheet.
15. Record the CO<sub>2</sub> Cell Voltage value displayed on the digital multimeter in the “As Found Cell Voltage” box on the *Functional Verification Report* sheet.
16. The CO<sub>2</sub> cell voltage must be **2.50 volts +/- 0.07 volts**. If not, the coarse zero potentiometer on the CO<sub>2</sub> cell must be adjusted. Skip to Step 17 if the cell voltage is within the specifications.
  - a) Nitrogen must be flowing while this adjustment is made.
  - b) The coarse zero potentiometer is located on the side of the CO<sub>2</sub> cell near the bottom (Figure A3).



ATF-LS-FRL Servomex Gas Analyzer Functional Verification - Standard Operating Procedures	ID: 8000 Revision: 3
Authority: Technical Leader	Page: 4 of 13
Original maintained by Quality Programs; copies are uncontrolled.	

- c) The voltage is adjusted by rotating the screw on the potentiometer clockwise to increase the voltage or counter-clockwise to decrease the voltage.

*Note that the potentiometer is very sensitive, so only a minor adjustment is required. In addition, there is a delayed response when an adjustment is made. Therefore, only make minor adjustments and wait for the reading to stabilize before making any additional adjustments.*

17. Check the *CO2 DIF SIG* value on the gas analyzer screen. The value displayed should be **0.00 ± 0.05**. If not, the zero potentiometer for the *CO2 DIF SIG* must be adjusted. Skip to Step 18 if the cell voltage is within the specifications.

- a) The *CO2 DIF SIG* zero potentiometer is located behind TP 2 on the circuit board (Figure A2). The potentiometer is blue in color.
- b) The voltage is adjusted by rotating the screw on the potentiometer clockwise to increase the voltage or counter-clockwise to decrease the voltage.

18. Record both the adjusted Cell Voltage and Differential Signal in the “As Left” boxes on the *Functional Verification Report* sheet.

***If the adjustment could not be made to within the limits, make a note in the report indicating this issue. The unit must then be taken out of service and sent to the manufacturer for service/repair.***

19. Perform a “zero calibration” of the analyzer and check the reading on the display to ensure the *CO2* is at 0.0%.

Menu → Calibrate → [REDACTED] → *CO2* → Low CAL → Enter “0.000%” → Enter

- Press MEASURE to exit back to the main measurement screen.

20. Remove the *CO* cell.

- a) The *CO* cell is a long black tube located on the right hand side of the chassis (Figure A1). It is also located above the transformer.
- b) Unscrew the *CO* cell from the right side of the chassis.
- c) Lift the cell out to get easy access to the coarse zero adjustment potentiometer.

21. Locate the *CO* transducer board on the U-shaped mounting bracket. The *CO* transducer board is located farthest from the front panel and opposite of the *CO2* transducer board (Figure A1).



ATF-LS-FRL Servomex Gas Analyzer Functional Verification - Standard Operating Procedures	ID: 8000 Revision: 3
Authority: Technical Leader	Page: 5 of 13
Original maintained by Quality Programs; copies are uncontrolled.	

22. Connect the leads of the multimeter to TP7 and TP 2 on the CO transducer board. The TP 7 is typically positioned on the top left hand side of the printed circuit board and TP 2 is on the same side towards the bottom of the board (Figure A4, note TP 2 is not visible in Figure A4). Verify the connection points prior to connecting the multimeter (they are labeled on the board), as the transducer board is not always oriented the same way for all analyzers.
23. Check the Differential Signal for the CO cell (*CO DIF SIG*) on the gas analyzer screen.
  - a) Push the *Menu* button on the gas analyzer and select *Diagnostics* from the *Setup* menu.

SETUP→DISPLAY→DIAGNOSTICS

- b) Press the up arrow on the gas analyzer until *I2 CO DIF SIG* is displayed on the screen.
24. Record the CO DIF SIG value displayed on the gas analyzer in the “As Found DIF SIG” box on the *Functional Verification Report* sheet.
25. Record the CO Cell Voltage value displayed on the digital multimeter in the “As Found Cell Voltage” box on the *Functional Verification Report* sheet.
26. The CO cell voltage must be **2.50 volts +/- 0.07 volts**. If not, the coarse zero potentiometer on the CO cell must be adjusted. Skip to Step 27 if the cell voltage is within the specifications.
  - a) Nitrogen must be flowing while this adjustment is made.
  - b) The coarse zero potentiometer is located on one of the mounts of the CO cell near the bottom (Figure A5).
  - c) The voltage is adjusted by rotating the screw on the potentiometer clockwise to increase the voltage or counter-clockwise to decrease the voltage.

*Note that the potentiometer is very sensitive, so only a minor adjustment is required. In addition, there is a delayed response when an adjustment is made. Therefore, only make minor adjustments and wait for the reading to stabilize before making any additional adjustments.*

27. Check the *CO DIF SIG* value on the gas analyzer screen. The value displayed should be **0.00 ± 0.05**. If not, the zero potentiometer for the *CO DIF SIG* must be adjusted. Skip to Step 28 if the cell voltage is within the specifications.
  - c) The CO DIF SIG zero potentiometer is located behind TP 2 on the circuit board. The potentiometer is blue in color.



ATF-LS-FRL Servomex Gas Analyzer Functional Verification - Standard Operating Procedures	ID: 8000 Revision: 3
Authority: Technical Leader	Page: 6 of 13
Original maintained by Quality Programs; copies are uncontrolled.	

- d) The voltage is adjusted by rotating the screw on the potentiometer clockwise to increase the voltage or counter-clockwise to decrease the voltage.
28. Record both the adjusted Cell Voltage and Differential Signal in the “As Left” boxes on the *Functional Verification Report* sheet.

***If the adjustment could not be made to within the limits, make a note in the report indicating this issue. The unit must then be taken out of service and sent to the manufacturer for service/repair.***

29. Perform a “zero calibration” of the analyzer and check the reading on the display to ensure the CO is at 0.0%.

**Menu → Calibrate → [REDACTED] → CO → Low CAL → Enter “0.000%” → Enter**

- Press MEASURE to exit back to the main measurement screen.
30. Reattach the CO cell to the side of the chassis and reinstall the CO/CO<sub>2</sub> transducer board mounting bracket.
31. Reattach the top cover of the analyzer chassis
32. Stop the flow of nitrogen to the gas analyzer.
33. Turn off the gas analyzer.
34. If the analyzer has passed the cell voltage/differential signal adjustment procedure, ensure that it is placed into one of the six (6) analyzer exercise rack slots for the drift test.
35. Save the *Functional Verification Report* file on the Occoquan share drive (Occoquan\Calibration Lab\Gas Analyzer\Functional Verification\CO-CO<sub>2</sub> Cell Voltage and Diff Sig) in the folder matching the FRL asset number of the gas analyzer. Use the following format for the file name: *Analyzer Asset Number - Cell Voltage and Differential Sig Date*.

## **B. Oxygen Span Drift Test**

The following steps describe the procedure to run a span drift test with the O<sub>2</sub> transducer. The following limits for O<sub>2</sub> drift have been adopted from FTT [3]:

- 50 ppm drift/50 ppm noise.
1. Setup the O<sub>2</sub> Span drift test in FireTOSS.
- a) Add the *Functional Verification Drift Object* into the test.
  - b) Select the desired rack for the analyzer to be tested (this pulls in the correct FireTOSS tags).



ATF-LS-FRL Servomex Gas Analyzer Functional Verification - Standard Operating Procedures	ID: 8000 Revision: 3
Authority: Technical Leader	Page: 7 of 13
Original maintained by Quality Programs; copies are uncontrolled.	

- c) Make sure to fill in all required fields.
2. Ensure that the nitrogen gas bottle for the exercise rack is open and set to at least 15 psig.
3. Select the rack slot for the desired analyzer on the main window of the touch screen located in the rack to the left of the analyzers. Then select the window on the screen for that analyzer. Press the Oxygen Zero button for nitrogen flow. Ensure that the O<sub>2</sub> transducer is receiving 5 psi of gas flow.
4. Allow nitrogen to flow for 10 minutes and then perform a manual low (zero) calibration on the analyzer.
5. After the zero calibration, turn off the flow of nitrogen to the analyzer and close the valve to the nitrogen bottle.
6. Ensure that the Oxygen Span gas bottle for the exercise rack is open and set to at least 15 psi.
7. Select the rack slot for the desired analyzer on the touch screen located in the rack to the left of the analyzers. Press the Oxygen Span button for Span gas flow. Ensure that the O<sub>2</sub> transducer is receiving 5 psi of gas flow.
8. Start the test in iFix. The first 15 minutes of the test will allow the analyzer to purge and stabilize, and the remaining 30 minutes will be used for calculations. MAKE SURE TO RUN A HIGH CALIBRATION OF THE OXYGEN CELL TO THE VALUE LISTED ON THE GAS BOTTLE AFTER 10 MINUTES.
9. Upon completion of the O<sub>2</sub> Drift test, end the FireTOSS experiment, turn off the flow of gas by pressing the Oxygen Span Button on the touch screen and close the valve on the oxygen span bottle.

### C. CO/CO<sub>2</sub> Span Drift Test

The following steps describe the procedure to run a span drift test with the CO/CO<sub>2</sub> transducers. The limit for CO<sub>2</sub> drift has been established after consideration of FTT documentation [3] and experimental data collected at the FRL. The limits for CO drift have been adopted from FTT [3]:

- CO<sub>2</sub>: 50 ppm drift / 50 ppm noise
  - CO: 100 ppm drift / 100 ppm noise
1. Setup the CO/CO<sub>2</sub> Span drift test in FireTOSS
    - a) Add the Functional Verification Drift Object into the test.
    - b) Select the desired rack for the analyzer to be tested (this pulls in the correct FireTOSS tags).
    - c) Make sure to fill in all required fields.



ATF-LS-FRL Servomex Gas Analyzer Functional Verification - Standard Operating Procedures	ID: 8000 Revision: 3
Authority: Technical Leader	Page: 8 of 13
Original maintained by Quality Programs; copies are uncontrolled.	

2. Ensure that the nitrogen gas bottle for the exercise rack is open and set to at least 15 psig.
3. Select the rack slot for the desired analyzer on the touch screen located in the rack to the left of the analyzers. Press the *CO/CO<sub>2</sub> Zero* button to start the flow of nitrogen. Ensure that the *CO/CO<sub>2</sub>* transducers are receiving 5 psi of gas flow.
4. Allow nitrogen to flow for 10 minutes and then perform a manual low (zero) calibration on the analyzer.
5. After the zero calibration, turn off the flow of nitrogen to the analyzer and close the valve to the nitrogen bottle.
6. Ensure that the *CO/CO<sub>2</sub> Span* gas bottle for the exercise rack is open and set to at least 15 psi.
7. Select the rack slot for the desired analyzer on the touch screen located in the rack to the left of the analyzers. Press the *CO/CO<sub>2</sub> Span* button for to start the flow of the span gas. Ensure that the *CO/CO<sub>2</sub>* transducers are receiving 5 psi of gas flow.
8. Start the test in iFix. The first 15 minutes of the test will allow the analyzer to purge and stabilize, and the remaining 30 minutes will be used for calculations. MAKE SURE TO RUN A HIGH CALIBRATION OF THE *CO/CO<sub>2</sub>* CELLS AFTER 10 MINUTES.
9. Upon completion of the *CO/CO<sub>2</sub>* Drift test, end the FireTOSS experiment, turn off the flow of gas by pressing the *CO/CO<sub>2</sub> Span* Button on the touch screen, and close the valve on the *CO/CO<sub>2</sub>* span bottle.

## 5. Shutdown Procedure

- A. Verify that all of the gas bottles are closed. Verify that all analyzer slots on the main screen of the touch screen are turned off.
- B. If the gas analyzer is to be place in a different rack, then remove it from the exercise rack and place in the appropriate gas analyzer rack. Otherwise, leave the unit in the exercise rack.
- C. If the analyzer meets all specifications from each test, have the Calibration Tech printout a new calibration sticker and place it on the gas analyzer. In addition, have the Calibration Tech verify that the gas analyzer is assigned to the correct location (e.g., 1 MW Square FPC) in the calibration database.



ATF-LS-FRL Servomex Gas Analyzer Functional Verification - Standard Operating Procedures	ID: 8000 Revision: 3
Authority: Technical Leader	Page: 9 of 13
Original maintained by Quality Programs; copies are uncontrolled.	

## 6. Maintenance Procedure

- If the gas analyzer cannot be brought into specifications, then the unit must be sent to the manufacturer for further analysis.

## 7. Functional Verification Procedure

- This procedure shall be performed annually. It may be performed more frequently, if there appears to be issues with the gas analyzer.

## References

1. *How to adjust the CO<sub>2</sub> cell voltage (FTT version) v.2.docx*, Fire Testing Technology Limited, West Sussex, United Kingdom, 2014
2. *How to adjust the CO cell voltage.pdf*, Fire Testing Technology Limited, West Sussex, United Kingdom, 2008
3. *Servomex Analyzer Service Report*, Fire Testing Technology Limited, West Sussex, United Kingdom, November 15, 2016



### Appendix A – Photographs

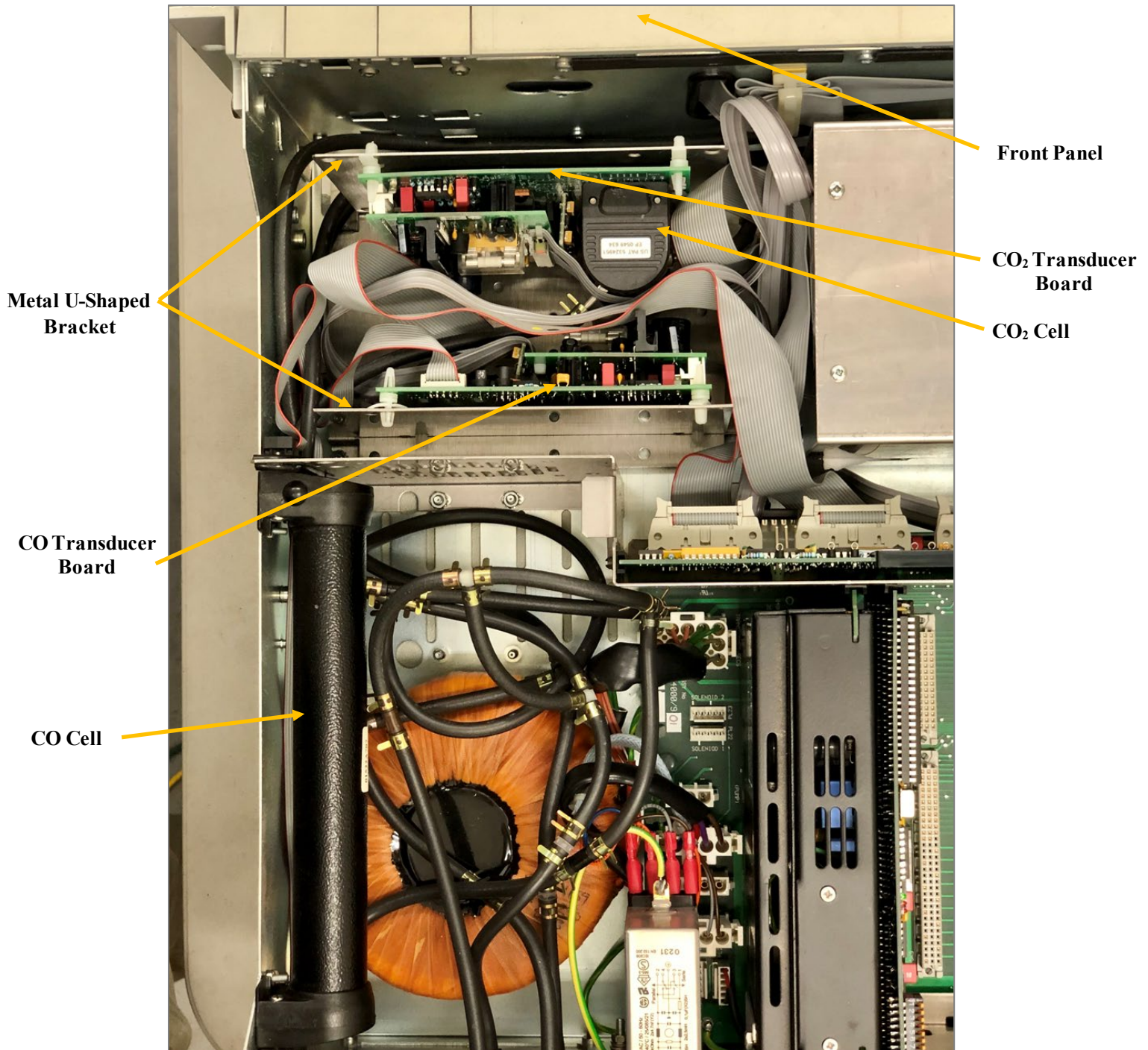

Figure A1. Internal components of the Servomex Gas Analyzer



CO<sub>2</sub> Transducer Board

TP 7

TP 2

CO<sub>2</sub> Dif Sig  
Zero

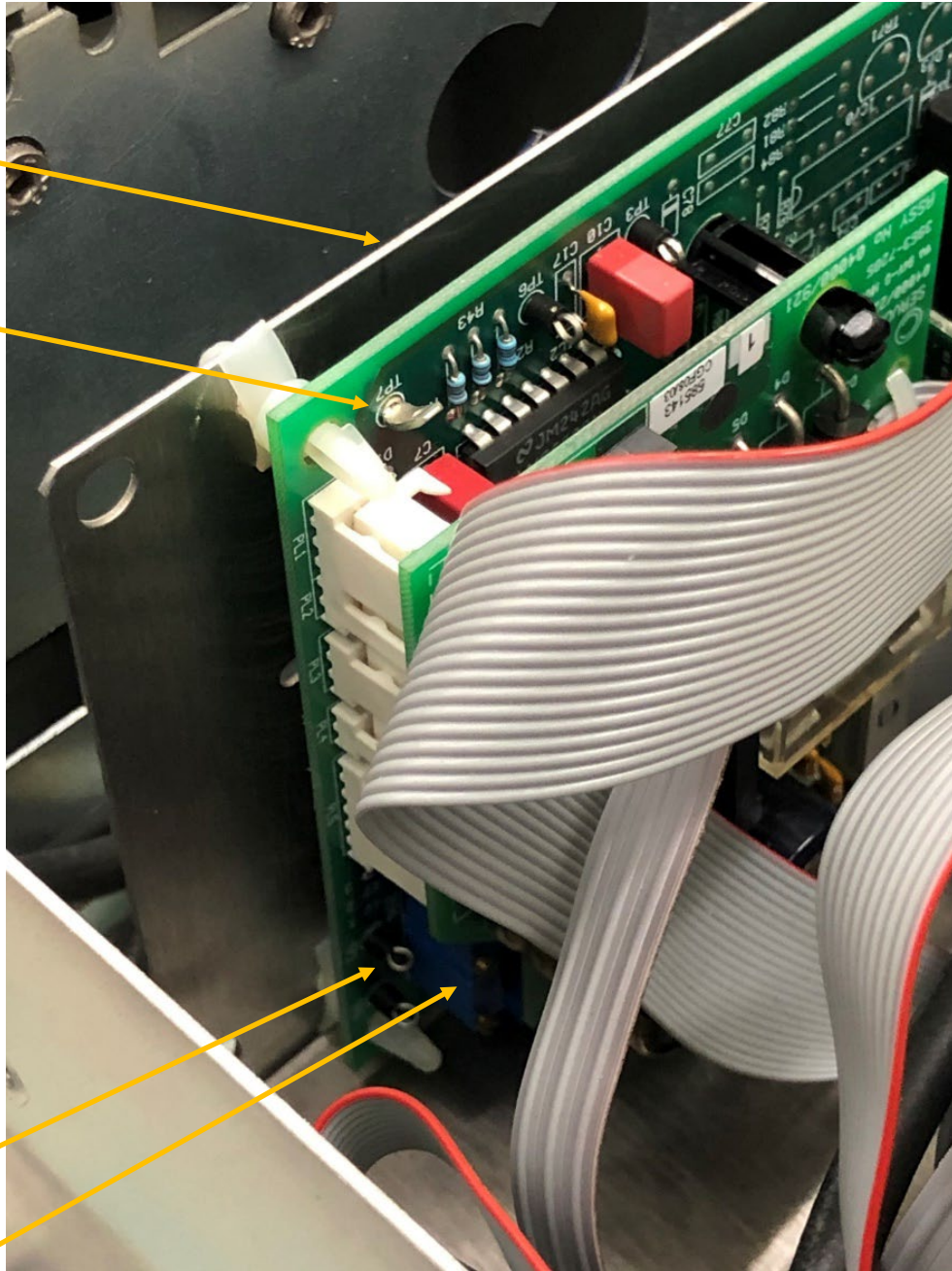

Figure A2. CO<sub>2</sub> Transducer Board



**Figure A3. CO<sub>2</sub> Cell Coarse Zero Potentiometer**



**Figure A4. CO Transducer Board**



**Figure A5. CO Cell Coarse Zero Potentiometer**



ATF-LS-FRL Siemens Gas Analysis Cart- Standard Operating Procedures	ID: 1584 Revision: 5
Authority: Technical Leader	Page: 1 of 7
Original maintained by Quality Programs; copies are uncontrolled.	

## 1. Scope

This Standard Operating Procedure (SOP) is to be used with the Siemens Gas Analysis Cart. The gas cart contains two sets of Siemens Oxymat 61 Oxygen (O<sub>2</sub>) analyzer and the Siemens Ultramat 23 Carbon Monoxide (CO)/Carbon Dioxide (CO<sub>2</sub>) gas analyzers, in addition to the other components required to obtain gas samples (sample pump, filters, etc.). The movable Siemens gas analysis cart is shown in Figure 1.



**Figure 1. Siemens Gas Analysis Cart**

## 2. Supplies Required

### A. Tubing, 3/8 inch diameter

1. Use stainless steel tubing if near fire/heat source, otherwise use plastic tubing.
2. Transition to plastic tubing away from the fire/heat source, if stainless steel tubing is initially used.

### B. Calibration Gases

1. Nitrogen (N<sub>2</sub>) Zero Gas (100%)
  - a. One (1) Cylinder with dual output adapter
    - i. One 0-25 psig CGA 580 regulator; to use as calibration zero gas
    - ii. One 0-200 psig CGA 580 regulator, as reference gas for the oxygen analyzer



ATF-LS-FRL Siemens Gas Analysis Cart- Standard Operating Procedures	ID: 1584 Revision: 5
Authority: Technical Leader	Page: 2 of 7
Original maintained by Quality Programs; copies are uncontrolled.	

- b. 1/4 in. tubing and Swagelok fittings
- 2. CO/CO<sub>2</sub>/N<sub>2</sub> span gas (4.5% CO / 22.5% CO<sub>2</sub> / N<sub>2</sub> Balance)
  - a) 1 Cylinder with 0-25 psig CGA 350 regulator,
  - b) 1/4 in. tubing and Swagelok fittings

**C. ELECTRICAL POWER**

- 120 VAC power to power analyzers and sampling pump
- Single extension cord required

**D. DESICCANT**

- Used for removal of liquid from gas sample

**E. ICE SUPPLY**

- For use with the cold trap

**3. Initial Setup**

The overall layout of the flow paths for the sample gas and calibration gases are shown in Figure 2.

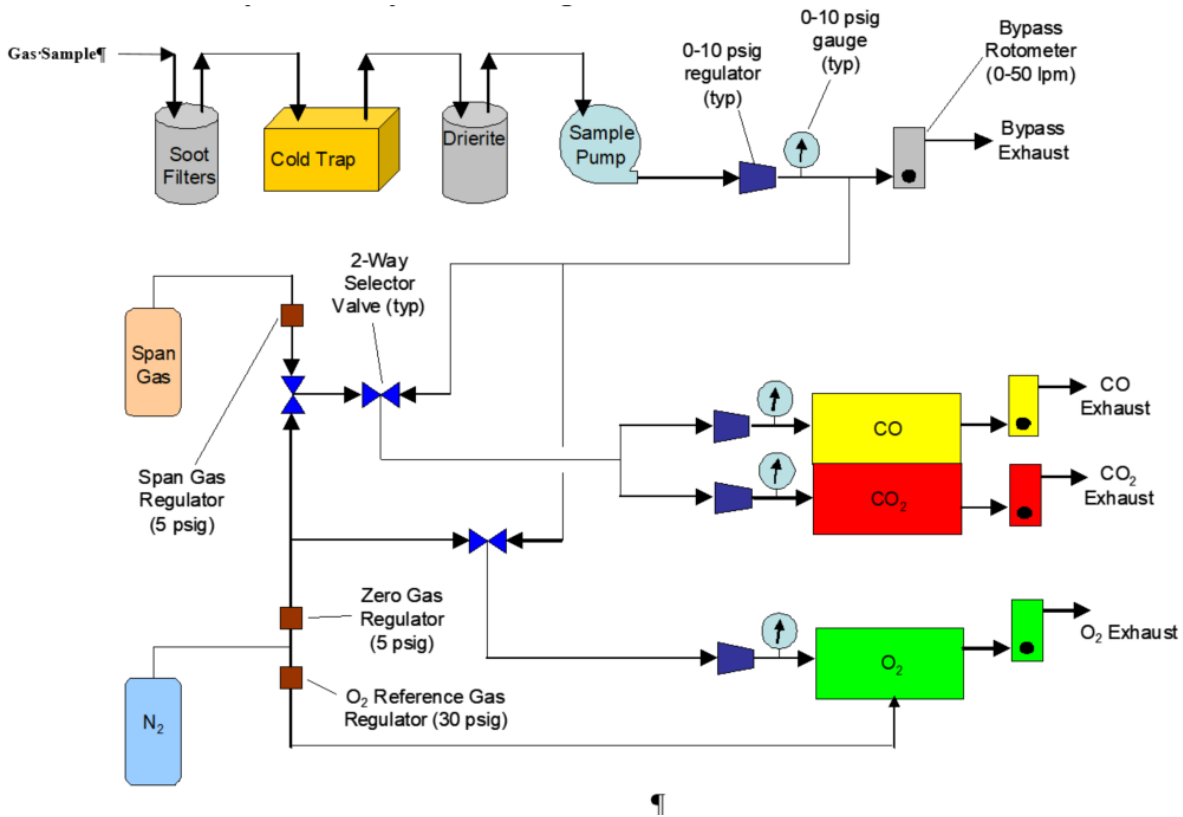

**Figure 2 - Gas Analysis Cart Flow Diagram**



ATF-LS-FRL Siemens Gas Analysis Cart- Standard Operating Procedures	ID: 1584 Revision: 5
Authority: Technical Leader	Page: 3 of 7
Original maintained by Quality Programs; copies are uncontrolled.	

- A. Connect CO/CO<sub>2</sub> span gas to Swagelok inlet port on front of cart.
- B. Connect N<sub>2</sub> zero gas to the Swagelok inlet port on the front of the cart.
- C. Connect N<sub>2</sub> reference gas to the Swagelok inlet port on the front of the cart
- D. Connect sample line tubing to sintered metal filter inlet on side of cart.
- E. Connect tubing between sintered metal filter outlet and cold trap.
- F. Connect tubing between cold trap and desiccant filter column.
- G. Connect tubing between desiccant filter column and sample inlet port on side of cart.
- H. Connect analyzer and bypass exhaust tubing to exhaust connections on side of cart, if used.
- I. Connect data output wires to data acquisition (DAQ) box.
  1. Three (3) connections required; one for each gas (CO, CO<sub>2</sub>, O<sub>2</sub>)
  2. Each gas measured by the gas analyzer has a current output signal of 4-20 mA. This current output signal is converted to a 1-5 VDC output signal by connecting a 250 ohm resistor across the connections for the output signals.

**Note: Tubing for most connections is stored in storage cabinet on cart and is color coded for ease of connecting.**

**Note: Do Not Turn Analyzers On At This Time!**

#### **4. Start-Up and Pre-Test**

- A. Check/clean filters and sampling line.
  1. Replace desiccant in tube on side of cart if necessary. If using Drierite, it is blue when ready to use and pink when it needs to be replaced.
  2. Check/clean cold traps and fill cooler containing cold traps on top of cart with ice.
  3. Check/clean sintered metal filters on side of cart.
  4. Blow out sample line utilizing compressed air. **Always Blow Compressed Air Away from Analyzer Inlet.**
- B. Start flow of reference gas to oxygen analyzer. Set regulator to 30 psig.
- C. Start flow of zero gas, N<sub>2</sub> to CO/CO<sub>2</sub> analyzer.
  1. Cylinder valve open and regulator set to ~5 psig.



ATF-LS-FRL Siemens Gas Analysis Cart- Standard Operating Procedures	ID: 1584 Revision: 5
Authority: Technical Leader	Page: 4 of 7
Original maintained by Quality Programs; copies are uncontrolled.	

2. Middle ball valve on front of cart set to calibrate.
  3. Bottom ball valve on front of cart set to nitrogen.
  4. Adjust rotometer valves for CO and CO<sub>2</sub> to get flow indicators on front of analyzer to middle of tube (1 LPM each). Adjust rotometer valves for O<sub>2</sub> to 0.5 LPM.
- D. Connect electrical power to cart and allow analyzers to warm-up for 30 min.
1. CO/CO<sub>2</sub> analyzer will go through AutoCal cycle twice – 5 min into warm-up and 30 min into warm-up.
  2. Press Esc when prompted to complete AutoCal.
- E. Calibrate analyzers.
1. Zero Calibration
    - a) Start flow of zero gas, N<sub>2</sub>, to both O<sub>2</sub> and CO/CO<sub>2</sub> analyzers
      - 1) N<sub>2</sub> cylinder valve open and regulator set to 5 psig
      - 2) Top ball valve (O<sub>2</sub>) on front of cart set to “Zero Gas”
      - 3) Adjust rotometer valve for O<sub>2</sub> to get 0.5 LPM
      - 4) Bottom ball valve on front of cart set to “N<sub>2</sub>”
      - 5) Middle ball valve on front of cart set to “Calibrate”
      - 6) Adjust rotometer valves for CO and CO<sub>2</sub> to get flow indicators on front of analyzer to middle of tube (1 LPM each)
      - 7) Adjust all three sample pressure using the regulators plumbed to the discharge side of the analyzers. CO/CO<sub>2</sub> = 2 psig, O<sub>2</sub> = 3 psig.
    - b) Calibration of Siemens Ultramat 23 CO/CO<sub>2</sub> analyzer
      - 1) Press Cal button on front of analyzer
      - 2) Press Esc when prompted
    - c) Calibration of Siemens Oxymat 61 O<sub>2</sub> analyzer
      - 1) Press **Enter** on the blue pad on front of Analyzer near O<sub>2</sub> on screen
      - 2) Use blue pad to select “Calibration”
      - 3) Enter “222” followed by the Enter key if prompted for code
      - 4) Select “Zero Calibration”
      - 5) Select “Start Calibration”
      - 6) Use **ESC** key to return to calibration menu



ATF-LS-FRL Siemens Gas Analysis Cart- Standard Operating Procedures	ID: 1584 Revision: 5
Authority: Technical Leader	Page: 5 of 7
Original maintained by Quality Programs; copies are uncontrolled.	

## 2. Span Calibration

- a) Start flow of span gas to CO/CO<sub>2</sub> analyzers
  - 1) Span gas cylinder valve open and regulator set to 5 psig
  - 2) Switch bottom ball valve on front of cart set to “Cal Gas”
  - 3) Middle ball valve on front of cart set to “Calibrate”
  - 4) Adjust rotometer and regulator valves for CO and CO<sub>2</sub> to get flow indicators on front of analyzer to middle of tube (1.0 LPM each) and 2 psig, respectively.
- b) Calibration of Siemens Ultramat 23 CO/CO<sub>2</sub> Analyzer
  - 1) Press **Enter** button on front of analyzer to go to Main Menu
  - 2) Use arrow keys to select “Calibration” and press Enter button
  - 3) Use arrow keys to enter “222” as Code
  - 4) Select “Calibr. IR Channels”
  - 5) Select “CO” using arrow keys
  - 6) If this is the first test of the series, select “Set Span Gas Values” and verify M1 and M2 are same as cylinder span gas values, adjust if necessary. Press Enter to return to CO calibration menu.
  - 7) Select “Start with MR1”
  - 8) Displayed set span should match span gas CO concentration (on cylinder label – 4.5%)
  - 9) Press **Enter** when prompted
  - 10) Press **Esc** to return to component selection menu
  - 11) Select CO<sub>2</sub> using arrow keys
  - 12) If this is the first test of the series, select “Set Span Gas Values” and verify M1 and M2 are same as cylinder span gas values, adjust if necessary. Press Enter to return to CO<sub>2</sub> calibration menu.
  - 13) Select “Start with MR1”
  - 14) Displayed set span should match span gas CO<sub>2</sub> concentration (on cylinder label – 22.5%)
  - 15) Press **Enter** when prompted
  - 16) Press **Esc** several times to exit menus
  - 17) Switch middle ball valve on front of cart to sample



ATF-LS-FRL Siemens Gas Analysis Cart- Standard Operating Procedures	ID: 1584 Revision: 5
Authority: Technical Leader	Page: 6 of 7
Original maintained by Quality Programs; copies are uncontrolled.	

- c) Calibration of Siemens Oxymat 61O2 analyzer
  - 1) Switch top ball valve on front of cart to sample
  - 2) Start pump using toggle switch at top of cart
  - 3) Adjust bypass rotometer flow so that the bypass pressure gauge on side of cart reads 4 psig.
  - 4) Adjust oxygen rotometer valve and regulator to get 0.5 LPM and 3 psig.
  - 5) Adjust CO and CO2 Rotometer Valves and Regulators to get 1.0 LPM and 2 psig.
  - 6) Readjust all three sets of rotometers and regulators to achieve desired flow rates and pressure if necessary.
  - 7) Select “Span Calibration”
  - 8) Select “Start Calibration”
  - 9) Use **ESC** key to exit menus

F. Check flow rates and pressures through cart.

1. Adjust bypass rotometer valve to so that bypass pressure gauge reads 4 psig.
2. Adjust O2 rotometer and regulator valves to get flow rate of 0.5 LPM and pressure of 3 psig.
3. Adjust CO and CO2 rotometers and regulator valves to get flow indicators on front of analyzer to middle of tube (1.0 LPM each) and 2 psig, respectively.

## 5. Determine Analyzer Response Delay Time

- A. Fill gas bladder with CO/CO<sub>2</sub> span gas.
- B. With data acquisition running, attach bladder valve to end of sample line.
- C. The time from when the bladder valve is turned on to the initial response by the analyzer is the delay time. Repeat 2-3 times and then use the average of the delay times.

## 6. Experiment Procedures

- A. Monitor data to ensure that no anomalies occur.
- B. If all gas measurements drop drastically, then the most likely issue is that the sample line or filter is clogged, and insufficient gas is reaching the analyzer.
  1. Check flow rate through analyzers.



ATF-LS-FRL Siemens Gas Analysis Cart- Standard Operating Procedures	ID: 1584 Revision: 5
Authority: Technical Leader	Page: 7 of 7
Original maintained by Quality Programs; copies are uncontrolled.	

2. Stopping of flow during test would be due to clog in sample line and data after clog would not be reflective of conditions at measuring point.
  - a) O<sub>2</sub> analyzer will give a zero value when flow of sample has stopped.
  - b) CO and CO<sub>2</sub> analyzers will hold the last value when the sample flow has stopped.
3. The pump to the gas analyzer should be turned off and an event shall be added to the experiment noting that the pump to the gas analyzer was turned off.
4. If the issue is resolved (e.g., filter replaced), then an event shall be added to the experiment noting when the pump to the gas analyzer was turned on.

## **7. Shut-Down and Post-Test**

- A. Shut down pump with toggle switch on front of cart.
- B. Shut down power to analyzers if testing series has concluded.

## **8. Maintenance Procedures**

- A. Blow out sample lines using compressed air prior to each test series or as needed.
- B. Change paper filters located in metal filter housing on side of rack as needed. Clean or change sintered metal filter as needed. These filters keep soot and debris out of the pump and analyzers.
- C. Change the desiccant when needed. If using Drierite, it should be blue in color when ready to use and pink when it needs to be replaced. If the desiccant is not changed frequently, excess water could enter the pump or gas analyzer.

## **9. Calibration**

- A. Perform a calibration prior to first test of each day or as needed/desired.
- B. The Siemens analyzers require service/maintenance by Siemens every two years. Calibration records will be maintained by the FRL calibration technician.



ATF-LS-FRL Stopwatch - Standard Operating Procedures	ID: 1586 Revision: 4
Authority: Technical Leader	Page: 1 of 2
Original maintained by Quality Programs; copies are uncontrolled.	

## **I. Required Supplies**

- a. Functional stopwatch.
- b. Trained stopwatch operator.
- c. Access to the GPS clock in the Plenum Shed 1 (P-S1), which is located in the mezzanine above the Medium Burn Room.

## **II. Setup Procedures**

- a. Ensure that the stopwatch has been functionality verified in accordance with the procedure provided in the Calibration Procedures section of this document.
- b. Position stopwatch and operator appropriately to monitor event requiring stopwatch measurements.
- c. Familiarize operator with experiment to allow accurate stopwatch operations during experiment.
- d. If necessary, prepare materials for manually recording information from stopwatch.

## **III. Experiment Procedures**

- a. Operate the stopwatch according to test examiner's specifications.
- b. Monitor the functionality of the stopwatch throughout the test series.

## **IV. Shut-Down and Maintenance Procedures**

- a. Reset the stopwatch counter to zero.
- b. Inspect the stopwatch for excessive physical damage. If necessary, replace the stopwatch with a similar functioning unit that has been functionally verified.

## **V. Calibration Procedures**

- a. Stopwatches used at the FRL are not calibrated but are functionally verified on an annually basis using the procedures listed below. Functionally verified stopwatches are labeled with the date of the most recent functional verification as well as the due date for the next functional verification.
- b. Inspecting the functionality of a stopwatch
  - i. Have a trained stopwatch operator perform the functional verification using the Master GPS clock in the P-S1 of the FRL.
  - ii. Start the stopwatch and observe the starting time according to the GPS clock and allow the stopwatch to run for a predetermined amount of time.
  - iii. Stop the stopwatch at the end of the predetermined time period according to the GPS clock. Compare the duration measured by the stopwatch to the predetermined duration measured by the GPS clock and calculate the error in the stopwatch. Common durations and the associated maximum errors are shown in the table below.



ATF-LS-FRL Stopwatch - Standard Operating Procedures	ID: 1586 Revision: 4
Authority: Technical Leader	Page: 2 of 2
Original maintained by Quality Programs; copies are uncontrolled.	

**Table 1. Allowable error for various time periods**

Time Period (seconds)	Time Period (hours)	Maximum Allowable Error (seconds)
60	0.0167	±0.0167
1800	0.5	±0.5
3600	1	±1.0
14400	4	±4.0
28800	8	±8.0
43200	12	±12.0
86400	24	±24.0

- iv. If the duration measured by the stopwatch differs by less than 0.028% of the duration observed on the GPS clock, the stopwatch is functioning properly and suitable for testing.
- v. If the duration measured by the stopwatch differs by more than 0.028% of the duration observed on the GPS clock, the stopwatch is not suitable for testing.



ATF-LS-FRL Technical Research	ID: 1555 Revision: 4
Authority: Technical Leader	Page: 1 of 1
Original maintained by Quality Programs; copies are uncontrolled.	

1. **Title:** Procedure for Technical Research.
2. **Scope:**
  - 2.1. This document establishes a system for conducting technical research.
  - 2.2. The provisions of this document exclude data considered common knowledge.
3. **Description:**
  - 3.1. Technical research is performed to help answer questions through searching reference documents, product information or other sources of knowledge relevant to an engineering analysis.
  - 3.2. The source reference from which data is used in engineering analyses shall be documented in the “project file” or the report.
  - 3.3. Engineering judgment is to be used to assess the pertinence and accuracy of the data and the reference.
4. **Uncertainty**

Where appropriate, multiple references will be compared to assess the uncertainty of the reference data.
5. **Procedure**
  - 5.1. Potential reference documents may come from any reputable source.
  - 5.2. The pertinence and accuracy of the reference and the data is assessed.
  - 5.3. The source is documented in accordance with Section 6 below.
6. **Documentation**

Source documents shall be documented in a manner that allows it to be identified and located by other engineers with an equivalent level of training to that of the document author.



ATF-LS-FRL Thermocouple - Standard Operating Procedures	ID: 1588 Revision: 4
Authority: Technical Leader	Page: 1 of 2
Original maintained by Quality Programs; copies are uncontrolled.	

## 1. Initial Set-Up

This document contains the Standard Operating Procedures (SOP) for thermocouples used at the Bureau of Alcohol, Tobacco, Firearms and Explosives (ATF) Fire Research Laboratory (FRL). This SOP only applies to thermocouples made inhouse and does not apply to thermocouples that are integral with existing/purchased equipment (e.g., cone calorimeter).

## 2. Required Supplies

- Thermocouple with male connector
- Data acquisition system including a thermocouple (TC) module with a female connector (any Yokagowa main and sub unit)
- Heat source (open flame, lighter, heat gun, etc)
- Thermocouple extension wire with connectors (if necessary)

## 3. Start Up Procedures

### A. Prior to the start of the first test in the series

1. The data acquisition unit shall be checked to confirm calibration.
2. Plug thermocouple into a TC module of data acquisition system.
  - If TC extension wire is used, minimize the temperature gradient between the ends of the extension wire and any additional junctions.
3. Verify ambient temperature reading of thermocouple.
4. Apply a heat source such as an open flame or heat gun to thermocouple junction and verify temperature rise.

### B. Prior to each test in the series

- Verify ambient temperature reading of thermocouple.

## 4. Experiment Procedures

- A. Record the thermocouple reading for the duration of the experiment.
- B. If the thermocouple must be removed prior to the end of the experiment due to experiment design or damage. The elapsed time at which the thermocouple was removed and the reason for removal shall be recorded.

## 5. Shut Down Procedures

- A. After the experiment, the thermocouples in locations where they could have been damaged shall be examined for visible damage. Perform functional verification if necessary.



ATF-LS-FRL Thermocouple - Standard Operating Procedures	ID: 1588 Revision: 4
Authority: Technical Leader	Page: 2 of 2
Original maintained by Quality Programs; copies are uncontrolled.	

- B. If damage has occurred, the thermocouple shall be taken out of service at the time of the damage. The laboratory engineer shall review the data to determine if there is a noticeable event that marked the damage to the instrument. If not, the thermocouple shall be taken out of service for the entire test. After the thermocouple has been taken out of service, the calculations shall be redone.

## 6. Maintenance Procedures

- There is no maintenance performed on a thermocouple.
- If a thermocouple becomes damaged or inoperable, then the thermocouple shall be removed and replaced prior to the next test .

## 7. Calibration Procedures

- Due to the disposable nature of thermocouples, they undergo a functional verification procedure, rather than a calibration. The process for functional verification of a thermocouple is noted below:
  1. Verify ambient temperature reading of thermocouple.
  2. Apply a heat source such as an open flame or heat gun to thermocouple junction and verify temperature rise.

## 8. Best Practices

- A. Make thermocouples no longer than 75 ft.
- Limit the length of thermocouple wire and extension wire to 100 ohms of resistance as recommended by Omega Engineering Inc.
  - The resistance of 24 AWG thermocouple wire is approximately 0.75 Ohms/ft and 24 AWG extension wire at approximately 0.625 Ohms/ft.
  - When using thermocouples longer than 75 ft., measure the resistance.
- B. Be aware of radiative sources that could influence the accuracy of temperature reading. Shield thermocouples when practical or critical to the test results.
- C. Use small gage wire and relatively long insertion lengths to minimize conduction error. Considering a 24 AWG wire with a diameter of 0.5 mm, the corresponding minimum insertion length is 2.5 cm.
- D. Minimize the temperature gradient across any junctions
- Typically, run thermocouple wire outside of compartments before transitioning to extension wire.



ATF-LS-FRL Tube Burner - Standard Operating Procedures	ID: 1570 Revision: 4
Authority: Technical Leader	Page: 1 of 3
Original maintained by Quality Programs; copies are uncontrolled.	

## 1. Scope

This document contains the Standard Operating Procedure (SOP) for the Tube Burner used at the Bureau of Alcohol, Tobacco, Firearms and Explosives (ATF) Fire Research Laboratory (FRL).

## 2. Required Supplies

- Tube burner
- 7.6 cm (3 inch) stainless steel braided hose for natural gas transport
- 120 VAC electrical power – single extension cord
- FireTOSS connectivity – single ethernet cable
- FireTOSS client computer with LabView installed.

## 3. Start Up Procedure

### A. Tube Burner Set Up

1. Check calibration status of equipment.
2. Connect stainless steel braided hose from gas main on wall to burner.
  3. Connect burner to power outlet using extension cord. Confirm green power LED activated on left of burner electrical box.
4. Connect burner electrical box to FireTOSS port using ethernet cable.
5. Position burner where needed.

### B. Launch LabVIEW tube burner control program on FireTOSS computer.

1. Select “ATF Burner.lvproj” from computer desktop.
2. Confirm communication between LabVIEW and FieldPoint modules.

### C. Verify functionality of pilot spark igniter PRIOR to turning natural gas ON.

1. Select button next to “Start Igniters” in the CONTROLS section of the burner control program. If spark igniters do not function, check Fireeye module in the burner electrical box. If the “Fire” LED is illuminated, press the RESET button on the module.
2. After verifying functionality, deselect button next to “Start Igniters” to turn spark to turn off igniters.

### D. Turn natural gas ON in mezzanine.

1. Fully open gas valve on gas train.



ATF-LS-FRL Tube Burner - Standard Operating Procedures	ID: 1570 Revision: 4
Authority: Technical Leader	Page: 2 of 3
Original maintained by Quality Programs; copies are uncontrolled.	

2. Move control switch on gas train control box from OFF to LabVIEW position.
- E. Turn natural gas ON in burn room.
1. Pull out emergency shutoff “mushroom” button located on wall of burn room. Typically, the emergency shutoff button used is located on the wall in the Medium Burn Room near the 1 MW Round Fire Product Collector.
  2. Fully open gas main valve connected to stainless steel braided hose.
- F. Perform a leak check on all connections.

#### 4. Experiment Procedure

##### A. Burner Control using LabVIEW.

1. Select “ATF Burner.lvproj” from desktop, if LabVIEW program is not open.
2. To start a test, click the button with the arrow icon located near the top-left portion of the main page of the Calibration Burner Control and Data Acquisition screen.
3. Verify the “Flow Control Mode” switch in the Controls section of the page is set to “Auto”. If not, move the switch position from Manual to Auto.
4. In the Data Acquisition section of the page, select the PROFILE tab and then enter the desired values for time and heat release rate (HRR) into the ‘Manuel Entry Data’ table. This will be the HRR profile curve for the burner. The first step should be a minimum of 1000 kW and the last step must be 0 kW.
5. Click “Read Profile from Manual Entry” button, which is located above the manual entry data table. The values entered in the table will then be automatically loaded into the program and displayed in the ‘Profile Graph” on the right side of the page.
6. In the Data Acquisition section of the page, select the PID tab and make sure the ‘Max Valve Open’ light is ON. Then select the PROFILE tab to return to the profile details.
7. In the Controls section, click the SOLENOID POSITION button next to “Start Igniters” to ignite the igniters.
8. After the pilot flames are ignited, click RUN PROFILE in the Data Acquisition section to start the test.
9. To end the test, wait until the heat release rate profile drops to 0 kW (last profile step).
10. Deselect the solenoid position button next to “Start Igniters”.
11. Deselect the “Read Profile from Manual Entry” button. This will cause the program to stop reading the heat release rate profile.



ATF-LS-FRL Tube Burner - Standard Operating Procedures	ID: 1570 Revision: 4
Authority: Technical Leader	Page: 3 of 3
Original maintained by Quality Programs; copies are uncontrolled.	

B. During Test

1. Monitor pressure in flow meter to ensure adequate supply of natural gas.
2. Monitor burner heat release rate to verify desired flow.

**5. Shut Down and Post-Test**

- A. To Exit the program, click the EXIT button on the Controls section of the page.
- B. Turn natural gas OFF in burn room.
1. Turn wall main valve to OFF position.
  2. Allow gas in stainless steel line to burn off through pilot bank.
  3. After the gas has been purged from the line, push in emergency shutoff “mushroom” button located on wall of burn room.
- C. Turn natural gas OFF in mezzanine.
1. Fully close main gas valve on mezzanine gas train.
  2. Move toggle switch on control box from LabView to OFF position.
- D. Disconnect power and Ethernet cords from tube burner, if no other tests are being performed.

**6. Maintenance**

- A. Periodically check for leaks at connections.
- B. Make sure that spark igniters stay clean.

**7. Calibration**

The following instruments associated with the tube burner shall be calibrated annually.

- National Instruments FieldPoint modules in control box near mezzanine gas train.
- Pressure transducer in rotary flow meter, which is part of the mezzanine gas train.



ATF-LS-FRL- Fire Product Collectors – Standard Operating Procedure	ID: 2671 Revision: 4
Authority: Technical Leader	Page: 1 of 3
Original maintained by Quality Programs; copies are uncontrolled.	

## 1. Scope

This document provides the Standard Operating Procedures (SOP) for the Fire Product Collectors used in experiments at the Bureau of Alcohol, Tobacco, Firearms and Explosives (ATF) Fire Research Laboratory (FRL).

## 2. Required Instrumentation

- A. Fire Product Collector (FPC)
- B. Additional instrumentation based on the FPC Reported Quantity specified in the experiment design. A summary of the instrumentation required for each reported quantity is given in Table 1.

**Table 1: Summary of instrumentation necessary for each FPC Reported Quantity**

		Fire Product Collector Reported Quantity						
		Convective HRR	HRR	C Factor	Smoke Production	Species Production	Effective HOC	Mass Loss Rate
Instrumentation	Gas Analyzer		✓	✓		✓	✓	
	Velocity	✓	✓	✓	✓	✓	✓	
	Thermocouple	✓	✓	✓		✓	✓	
	Calibration Burner(s)			✓				
	FPC ODM				✓			
	Laboratory Conditions		✓	✓			✓	
	Weighing Device(s)				✓ (yield)	✓ (yield)	✓	✓



ATF-LS-FRL- Fire Product Collectors – Standard Operating Procedure	ID: 2671 Revision: 4
Authority: Technical Leader	Page: 2 of 3
Original maintained by Quality Programs; copies are uncontrolled.	

### 3. Start Up and Pre-Test Procedures

- A. Fire Lab Control System (FLCS)
  1. Bring building into Test Mode.
  2. Adjust the duct flow rate to the desired setting.
- B. Fire Products Collector (FPC)
  1. Verify the functionality and/or calibration status of all instrumentation to be used in an experiment (Table 1). Requirements are described in each respective Standard Operating Procedure (SOP).
  2. If using a weighing device or calibration burners, set up the instrumentation according to the instructions provided in the appropriate SOP. All other instrumentation is pre-installed.

### 4. Experiment Procedures

- A. Monitor data to ensure no anomalies occur.
- B. The output of all instrumentation used in the experiment shall be recorded for the duration of the experiment.
- C. When any instrument must be removed prior to the end of the experiment due to experiment design or impending damage, the elapsed time at which the instrument was removed and the reason for removal shall be recorded.
- D. Operate the FPC according to the examiner's specifications and within the operational limits of the FPC.
  - The FPCs are designed to have a nominal flow rate of 6.8 kg/s (12,000 standard cubic feet per minute (SCFM)) per 1 MW heat releases rate. Higher flow rates can be achieved, however the flow rate should be set according to the anticipated peak heat release rate.
  - The measured temperature at the instrumentation section should not exceed 300 °C (570 °F). If the temperature exceeds this threshold, the test engineer shall decide whether to terminate the experiment, increase the flow rate in the duct, or allow the experiment to continue.



ATF-LS-FRL- Fire Product Collectors – Standard Operating Procedure	ID: 2671 Revision: 4
Authority: Technical Leader	Page: 3 of 3
Original maintained by Quality Programs; copies are uncontrolled.	

## 5. Shut Down and Post Test Procedures

- A. Review data and check for any anomalies.
- B. If an instrument was taken out of service during a test, update the out of service time and out of service reason fields on the FireTOSS data sheet and redo the calculations.
- C. If conditions occurred, either during the test or following the test, that could potentially affect the performance of an instrument, a functional verification and/or maintenance shall be performed.
- D. If no more tests are planned for the day, shutdown the instruments according to the instructions provided in each SOP and bring building out of Test Mode.

## 6. Maintenance Procedures

- Any maintenance required for each instrument used in the experiment shall be performed according to requirements described in the respective SOP.

## 7. Calibration and Functional Verification Procedures

### A. Instrumentation

- Calibration and/or functional verification for each instrument used in the experiment shall be performed according to instructions in the respective SOP.

### B. C Factor

- Calibration of the FPC heat release rate shall be performed by calculating the calibration factor (C Factor).
  1. A heat release rate calibration experiment shall be conducted within 30 days of any test within the series.
  2. The C Factor shall be calculated following an experiment in which a calibration burner(s) is used to produce a series of fires with varying size.
  3. A calibration experiment shall include at least three (3) heat release rate steps. One step must include a 0 kW step.
  4. The maximum HRR step shall be selected based on the anticipated fire size.
  5. The calibration factor shall be between the values of 0.95 and 1.05.
  6. The calibration factor shall not vary by more than  $\pm 5$  percent from the previous calibration.
  7. If the C Factor does not meet the requirements in (6) or (7), the system shall be checked for problems. Once the problems have been resolved, a new C Factor experiment shall be conducted.



ATF-LS-FRL-FPC Laser Optical Density Meter - Standard Operating Procedures	ID: 5688 Revision: 3
Authority: Technical Leader	Page: 1 of 5
Original maintained by Quality Programs; copies are uncontrolled.	

## 1. Scope

This document contains the Standard Operating Procedure (SOP) for the Laser Optical Density Meter that is used with a Fire Product Collector (FPC) at the Bureau of Alcohol, Tobacco, Firearms and Explosives (ATF) Fire Research Laboratory (FRL).

## 2. Required Supplies

- ODM System Components
  - Laser assembly equipped with 0.5 mW He-Ne laser, compensating photodiode, filter housing and beam splitter
  - Main detector assembly equipped with main photodiode, filter housing and beam splitter
  - Amplifier module
  - Power supply module
  - Laser power supply
  - Blank (zeroing) insert, 0.3 OD, and 0.8 OD Neutral Density Filters
- 115 VAC electrical power
- Data acquisition hardware
- Data acquisition connectivity
- FireTOSS Client computer
- Compressed air source and plumbing to connect purge

## 3. Start Up Procedures

### A. Plumbing and Electrical/Data Connections

1. Plug the photodiode connections into the amplifier module and connect the amplifier module to the power supply module.
2. Connect the amplified detector leads from the power supply module to the appropriate channels on the data acquisition system.
3. Plug in the laser power supply and the detector power supply module.
4. Turn the laser power supply on and allow the laser to stabilize. The laser power should be kept on to extend the life of the unit.
5. Connect the purge air source.



ATF-LS-FRL-FPC Laser Optical Density Meter - Standard Operating Procedures	ID: 5688 Revision: 3
Authority: Technical Leader	Page: 2 of 5
Original maintained by Quality Programs; copies are uncontrolled.	

## B. System Alignment

1. Align the laser to maximize the main detector signal.
2. Perform a functional verification of the system.
  - The 0.5 mW lasers are powerful enough to saturate the photodiode detectors. The supplied filters can be used to verify that the system is operating in the linear range.
  - Placing a filter in the beam path should reduce the detector signal by a factor of  $10^{-(OD)}$ , where OD is the calibrated filter optical density.
  - The filters have nominal optical densities of 0.3 and 0.8, which correspond to factors of roughly 0.5 and 0.15, respectively.
  - If the signal is not reduced by the expected amount when a filter is put in place, the laser intensity may need to be reduced to bring the photodiode into the linear range.
  - Each detector module was shipped with an opal glass diffuser mounted in front of the photodiode. To further attenuate the laser intensity, a 1.6 mm (1/16 in.) thick PTFE (Teflon) disc was placed in front of the diffuser. Additional beam dissipation may be necessary to bring the photodiode into the linear range.
  - Adjust the gain on the amplifier module until the main and compensating photodiodes have a signal output between 1.5 V and 2.0 V. Figure 1 shows the location of the amplifier adjustment screws.

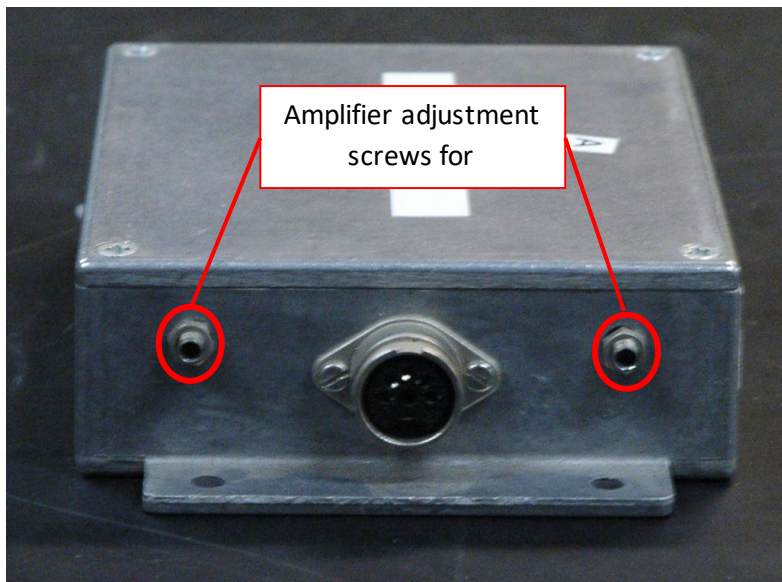

**Figure 1: Location of screws for adjusting photodiode output on the amplifier**



ATF-LS-FRL-FPC Laser Optical Density Meter - Standard Operating Procedures	ID: 5688 Revision: 3
Authority: Technical Leader	Page: 3 of 5
Original maintained by Quality Programs; copies are uncontrolled.	

## 4. Experimental Procedure

### A. Prior to First Test of Day

1. Ensure that the laser power supply is turned on. The laser system should be left on continuously to prolong the life of the laser. If the power supply is not turned on, turn it on and allow the laser to stabilize.
2. Ensure that the power supply module for the amplifier is plugged in.
3. Verify that the main and compensating photodiodes to have a signal output between 1.5 V and 2.0 V. If the signal is below 1.5 V, then the following steps may be taken:
  - a. Adjust the laser alignment. This should be done carefully as the photodiode surfaces are small and the detector output is very sensitive to laser alignment.
  - b. Clean any excess dirt off the sight glass and the laser system optics.
  - c. Check and, if necessary, adjust the amplification of the photodiodes.
4. Perform a system functional verification.
5. Verify that the purge air is flowing.

### B. Prior to Each Test

1. Verify that the output of each photodiode is stable for a period of at least two minutes.
2. System Balance
  - a. With no obstruction in the light path, record the signal outputs from the main and compensating photodiodes as  $V_{1,\text{main}}$  and  $V_{1,\text{comp}}$ , respectively.
  - b. Block the laser by placing a blank insert into the filter housing adjacent to the compensating photodiode. Record the signal outputs from the main and compensating photodiodes as  $V_{0,\text{main}}$  and  $V_{0,\text{comp}}$ , respectively.
  - c. Update the FireTOSS data sheet.
  - d. Ensure that the optical path is unobstructed prior to testing
3. System Calibration (Optional)
  - a. Insert a neutral density filter into the slot in the main detector assembly.
  - b. Record the filter optical density on the FireTOSS data sheet.
  - c. Record the signal output from the main photodiode as  $V_{\text{filter,main}}$ .
  - d. Update the FireTOSS data sheet.
  - e. Remove filter from the slot and ensure that the optical path is unobstructed prior to testing.



ATF-LS-FRL-FPC Laser Optical Density Meter - Standard Operating Procedures	ID: 5688 Revision: 3
Authority: Technical Leader	Page: 4 of 5
Original maintained by Quality Programs; copies are uncontrolled.	

### C. During Test

1. The output of the main and compensating photodiodes shall be recorded for the duration of the experiment.
2. If the ODM must be removed prior to the end of an experiment due to experiment design or system failure, then the elapsed time at which the laser was removed and the reason for instrument removal shall be recorded on the data sheet.

## 5. Shut Down and Post Test

- A. If an ODM was taken out of service during a test, update the out of service time and out of service reason fields on the FireTOSS data sheet and redo the calculations.
- B. If conditions occurred, either during the test or following the test, that could potentially affect the performance of the ODM, a functional verification shall be performed.
- C. If it is determined that damage has occurred or that maintenance needs to be performed, the ODM shall be taken out of service until it has been repaired or replaced.
- D. Unless the system needs to be shut down for maintenance or repair, power to the ODM components shall be left on.

## 6. Maintenance and Safety

- A. Laser windows on the FPC port should be checked periodically and cleaned as necessary.
- B. The ODM uses a 0.5 mW helium neon laser. Care must be taken when performing any installation, maintenance or repair operations as eye damage can occur with exposure to the beam.

## 7. Functional Verification

- A. Ensure that the laser system is turned on and has been given time to stabilize
- B. Perform a System Balance according to the procedure previously discussed in the *Experimental Procedure* section.
- C. Insert the 0.3 OD filter in the filter slot of the main detector assembly.
- D. Allow the system to stabilize and record the signal from the main and compensating photodiodes as  $V_{\text{filter,main}}$  and  $V_{\text{filter,comp}}$ , respectively.
- E. Calculate the normalized signal for each photodiode according to:

$$V_n = \frac{V_{\text{filter}} - V_0}{V_1 - V_0}$$

- F. Calculate the optical density using the following equation:

$$OD_{\text{meas}} = \log_{10} \frac{V_{n,\text{comp}}}{V_{n,\text{main}}}$$



ATF-LS-FRL-FPC Laser Optical Density Meter - Standard Operating Procedures	ID: 5688 Revision: 3
Authority: Technical Leader	Page: 5 of 5
Original maintained by Quality Programs; copies are uncontrolled.	

- G. If the calculated optical density agrees with the calibrated optical density of the filter within  $\pm 2\%$ , then repeat these procedures using the 0.8 OD filter.
- H. If the calculated optical density varies from the calibrated optical density of the filter by more than 2 %, then:
- Check that the compensating diode has a signal between 1.5 V and 2 V. If not, perform the steps in Section 4.A.3 and repeat the functional verification.
  - Check the system alignment, as discussed in Section 3.B.
  - If these steps do not resolve the issue, then the ODM shall be taken out of service until the calculated OD agrees with the calibrated filter OD within  $\pm 2\%$ .



ATF-LS-FRL-FPC White Light Optical Density Meter - Standard Operating Procedures	ID: 5689 Revision: 3
Authority: Technical Leader	Page: 1 of 4
Original maintained by Quality Programs; copies are uncontrolled.	

## 1. Scope

This document contains the Standard Operating Procedure (SOP) for the White Light Optical Density Meter used with a Fire Product Collectors (FPC) at the Bureau of Alcohol, Tobacco, Firearms and Explosives (ATF) Fire Research Laboratory (FRL).

## 2. Required Supplies

- ODM System Components
  - White light control unit
  - White light transmitter
  - White light receiver
  - Three neutral density filters covering a range of optical density (e.g., 0.1, 0.8 and 2.0)
- 115 VAC electrical power
- Data acquisition hardware
- Data acquisition connectivity
- FireTOSS Client computer
- Compressed air source and plumbing to connect purge

## 3. Start Up Procedure

### A. Plumbing and Electrical/Data Connections

1. Connect the light transmitter and receiver to the control unit.
2. Connect the signal leads from the control unit to the appropriate channels on the data acquisition system.
3. Plug in the control unit.
4. Connect the purge air source.

### B. System Alignment

1. Switch on the control unit and lamp.
2. Adjust the damping control switch to zero.
3. Align the light transmitter to center the beam on the window of the opposite side of the FPC duct.
4. Verify that the light beam diameter is approximately 3 cm at the location of the light receiver.



ATF-LS-FRL-FPC White Light Optical Density Meter - Standard Operating Procedures	ID: 5689 Revision: 3
Authority: Technical Leader	Page: 2 of 4
Original maintained by Quality Programs; copies are uncontrolled.	

5. Switch the control unit to “Calibrate” and use the adjusting screw on the light transmitter to give a reading of 1.5 V. The adjusting screw is shown in Figure 1.

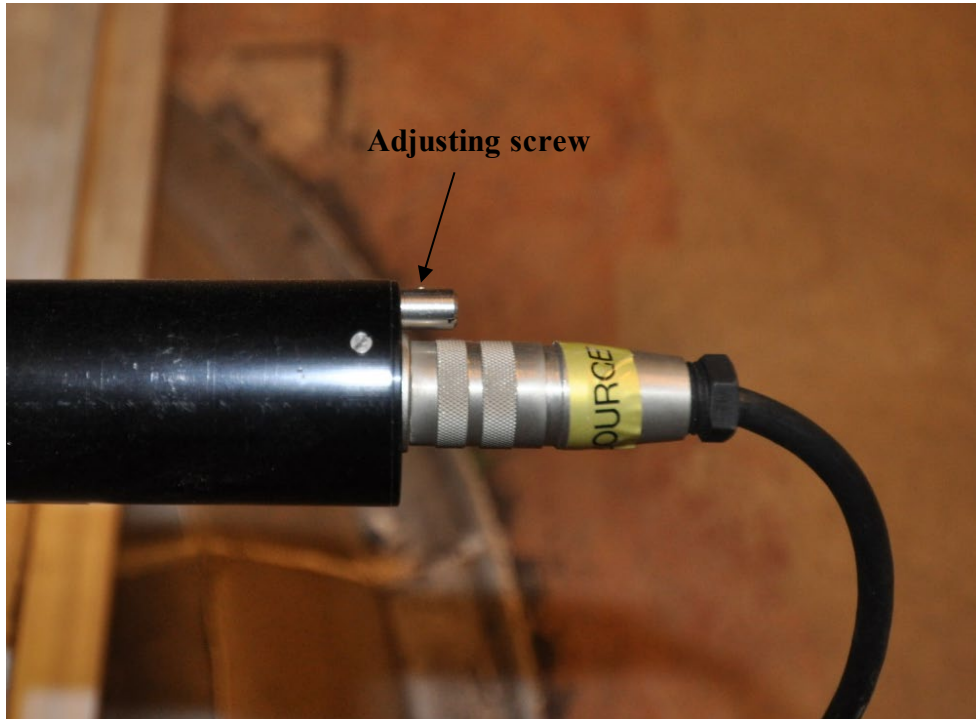

**Figure 1: Location of adjusting screw on light transmitter**

#### C. System Zero

1. Switch the control unit to “Measure.”
2. Insert a blank in the filter slot or otherwise block light from the receiver.
3. Adjust the “Zero” potentiometer on the control unit until the control unit display reads “0.00.”

#### D. System Span

1. Verify that the control unit is set to “Measure.”
2. Unlock the “Span” potentiometer by moving the small latch counterclockwise.
3. Verify that the light source is turned on and the path is unobstructed.
4. Adjust the “Span” potentiometer on the control unit until the control unit display reads “100.0.”
5. Lock the “Span” potentiometer by moving the small latch clockwise. If you accidentally move the “Span” potentiometer, then span the system again.



ATF-LS-FRL-FPC White Light Optical Density Meter - Standard Operating Procedures	ID: 5689 Revision: 3
Authority: Technical Leader	Page: 3 of 4
Original maintained by Quality Programs; copies are uncontrolled.	

- E. Perform a system functional verification.
- F. Remove filters and ensure that the optical path is unobstructed.
- G. Turn off the power to the lamp and control unit when the system is not in use.

#### 4. Experimental Procedure

##### A. Prior to First Test of Day

- 1. Turn on the power to the control unit and allow the system to stabilize.
- 2. Turn on the lamp power.
- 3. Zero and span the system.
- 4. Perform a system functional verification.
- 5. Verify that the purge air is flowing.

##### B. Prior to Each Test

- 1. Verify that the output from the light receiver is stable for a period of at least two minutes.
- 2. Zero the system and record the light receiver signal.
- 3. Span the system and record the light receiver signal.
- 4. Update the FireTOSS data sheet.
- 5. Ensure that the optical path is unobstructed.
- 6. System Calibration (Optional)
  - a) Insert a neutral density filter into the filter slot.
  - b) Record the light receiver signal.
  - c) Update the FireTOSS data sheet.
  - d) Remove filter from the slot and ensure that the optical path is unobstructed prior to testing.



ATF-LS-FRL-FPC White Light Optical Density Meter - Standard Operating Procedures	ID: 5689 Revision: 3
Authority: Technical Leader	Page: 4 of 4
Original maintained by Quality Programs; copies are uncontrolled.	

### C. During Test

1. The output of light receiver shall be recorded for the duration of the experiment.
2. If the ODM must be removed prior to the end of an experiment due to experiment design or system failure, then the elapsed time at which the ODM was removed and the reason for instrument removal shall be recorded on the data sheet.

## 5. Shut Down and Post Test

- A. If an ODM was taken out of service during a test, update the out of service time and out of service reason fields on the FireTOSS data sheet and redo the calculations.
- B. If conditions occurred, either during the test or following the test, that could potentially affect the performance of the ODM, a functional verification shall be performed.
- C. If it is determined that damage has occurred or that maintenance needs to be performed, the ODM shall be taken out of service until it has been repaired or replaced.
- D. The control unit power should be switched off overnight.
- E. The lamp power should be switched off between tests.

## 6. Maintenance and Safety

- Windows on the FPC ports should be checked periodically and cleaned as necessary.

## 7. Functional Verification

- A. Verify that the control unit is turned on and has been given time to stabilize.
- B. Verify that the light source power is on.
- C. Insert a neutral density filter in the filter slot.
- D. Verify that the measured transmission value agrees with the calibrated transmission of the filter. The filter transmission (T) can be calculated from the optical density (OD) according to:

$$T = 10^{-OD}$$

- E. Repeat steps c and d for two additional filters with different OD values.
- F. If the measured transmission varies from the calculated transmission from the calibrated filter by more than 2 %, perform troubleshooting steps and repeat the functional verification.



ATF-LS-FRL-LI001 Thermocouple	ID: 1587 Revision: 3
Authority: Technical Leader	Page: 1 of 10
Original maintained by Quality Programs; copies are uncontrolled.	

## Scope

This instruction covers the use, design, and specifications of thermocouples used at the Bureau of Alcohol, Tobacco, Firearms and Explosives (ATF) Fire Research Laboratory (FRL).

## Instrument Description

### GENERAL

A thermocouple is a temperature measurement sensor that consists of two dissimilar metals joined at one end (a junction) that produces a small thermo-electrical voltage when the wire is heated. The change in voltage is interpreted as a change in temperature. [1]

Although there are many configurations of thermocouples, there are five important factors to consider when using thermocouples for fire applications: temperature range, ruggedness, response time, wire tolerance limit, and grounded or ungrounded.

Temperature Range : The temperature range of a thermocouple is defined by the type and thickness of the metals used in their construction. The type of thermocouple is described using a letter nomenclature. Typical thermocouple types are J, K, T and E. For most fire applications, Type-K thermocouples with a maximum temperature range of approximately 1250 °C (2282 °F) are used. [1]

Ruggedness: The resistance of a thermocouple to environmental conditions is largely dependent on the type of junction and the wire insulation. Typically, thermocouples have either exposed or sheathed junctions. Exposed junction thermocouples have a faster response time but the junction is unprotected from the environment. Sheathed junction thermocouples are protected inside of a metal sheath, commonly constructed of Inconel, that provides environmental and abrasion resistance. However, sheathed thermocouples have a slower response time and a lower maximum temperature range because thinner wires are used within the metal sheathing. The ruggedness of thermocouples is mainly a function of the wire insulation material. Glass braid insulation has a temperature range of -73 °C to 260 °C and Nextel braid insulation has a temperature range of -73 °C to 1204 °C. Inconel is listed with a maximum temperature of 1150 °C. [1, Page H-5-7]

Response Time: The response time of a thermocouple is characterized by its “time constant” that is defined as the time required to achieve 62.3% of an instantaneous change. Factors that affect response time are wire gage, sheathed versus exposed junction, and grounding. For a 0.015 mm (0.001 inch) gage wire, the response time in a “still” air environment is approximately 0.05 sec [1, Table 2, Page A-18].

Wire Tolerance Limit: Thermocouple wire is generally available in more than one grade. The grade of wire refers to the tolerance limit specified for a particular thermocouple type. For



ATF-LS-FRL-LI001 Thermocouple	ID: 1587 Revision: 3
Authority: Technical Leader	Page: 2 of 10
Original maintained by Quality Programs; copies are uncontrolled.	

example, one manufacturer sells two grades: standard and special limits of error (SLE) [1]. Unless otherwise specified, Type-K SLE thermocouple wire is used at the ATF Fire Research Laboratory which has a minimum accuracy of the greater of 1.1°C or 0.4% of the temperature reading over 0°C. When there is a specific experiment requirement for a different level of accuracy, the actual measured thermocouple accuracy shall be documented in the “TC Type” FireTOSS input field.

Grounded Thermocouples: The difference between grounded and ungrounded thermocouples is that the junction of a grounded thermocouple is welded directly to the protective sheathing where as an ungrounded thermocouple junction is isolated from the sheathing. Grounded thermocouples are recommended for measurements of corrosive substances or in high pressure environments. Because the junction of a grounded thermocouple is welded to the sheath, the response time is faster than ungrounded thermocouples. However, a concern with grounded thermocouples is that many instruments can have ground loop problems.

## Uncertainty and Accuracy

In a thermocouple measurement, the reported temperature is that of the junction, or bead. Generally, however, the temperature of the thermocouple junction is different from the temperature of interest. In fire tests, the temperature of interest is typically that of the gases surrounding the thermocouple junction. The uncertainty associated with the measured junction temperature can be estimated based on specifications for a particular thermocouple and an analysis of the measurement system. The difference between the junction temperature and the temperature of the surrounding gases can be significant and is highly dependent on conditions associated with a particular experiment. The analysis that follows is divided into two sections: first, an analysis of the uncertainty associated with the junction temperature measurement (measurement error) and second, an analysis of the error associated with the differences between junction temperature and environment temperature (insertion error).

### **MEASUREMENT ERROR**

The uncertainty associated with the measured junction temperature is a primarily a function of the thermocouple/extension wire and any additional junctions such as when the thermocouple wire transitions to extension wire. The measurement system illustrated in Figure 1 is a common set-up used at the FRL. The analysis provided here is based on manufacturer specifications for Type-K thermocouples [1].

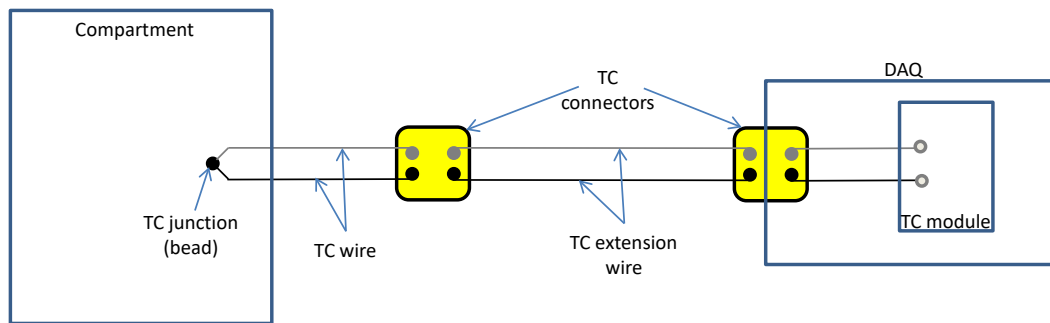

**Figure 1. Thermocouple measurement system**

Thermocouple wire can be specified as having either standard or special limits of error. The limit of error for standard Type-K thermocouples is the greater of  $2.2^{\circ}\text{C}$  or  $0.75\%$  of the temperature reading over  $0^{\circ}\text{C}$ . Special limit of error (SLE) Type-K thermocouples can be specified with a corresponding error limit that is the greater of  $1.1^{\circ}\text{C}$  or  $0.4\%$  of the temperature reading over  $0^{\circ}\text{C}$ . The maximum specified temperature of a Type-K thermocouple is  $1250^{\circ}\text{C}$ . At this temperature, the error associated with standard and SLE type-K thermocouples is  $9.38^{\circ}\text{C}$  and  $5^{\circ}\text{C}$ , respectively. [1, page H4] The FRL uses SLE thermocouple wire.

Thermocouple extension wire is fabricated from the same material as the thermocouple wire, and is also available in standard or SLE grades. The error associated with standard and SLE grades are, respectively,  $\pm 2.2^{\circ}\text{C}$  and  $\pm 1.1^{\circ}\text{C}$ . This error is valid in a temperature range is between  $0^{\circ}\text{C} - 200^{\circ}\text{C}$ . The error due to extension wire is only considered if there is a temperature gradient across the length of the extension wire.

Thermocouple connectors are commonly used to transition from the thermocouple to extension wire or extension wire to the data acquisition system. These junctions introduce uncertainty in the measurement if there is a temperature gradient across the junction and the junction is made of a different material than the thermocouple wire. This error is approximately the same as the temperature difference across the junction [2]. Junctions are generally small and are often insulated. The connectors used at the FRL are made of the same material as the thermocouple wire and are therefore ignored in this analysis.

Excessive wire lengths and the data acquisition system are other sources of error. However, these errors are generally small and are not considered in this analysis.

This analysis considers two scenarios. In the first scenario a SLE Type-K thermocouple is placed in a high temperature environment ( $1000^{\circ}\text{C}$ ), such as inside a compartment fire. The thermocouple lead extends outside the compartment where it is connected to standard Type-K extension wire that runs to the data acquisition system, shown in Figure 1. In this scenario the environment outside the compartment is between  $0^{\circ}\text{C} - 200^{\circ}\text{C}$  and is conditioned such that there is no temperature gradient between the TC/extension connection and the data acquisition system.



ATF-LS-FRL-LI001 Thermocouple	ID: 1587 Revision: 3
Authority: Technical Leader	Page: 4 of 10
Original maintained by Quality Programs; copies are uncontrolled.	

In this scenario, because there is no temperature gradient at any of the junctions or across the extension wire, the connections and extension wire can be ignored in the uncertainty analysis. The measurement error is only associated with the error of the thermocouple wire.

For SLE K-type wire at 1000°C, the corresponding error is 0.4%, or 4°C. Assuming a square probability distribution, the standard uncertainty is obtained by dividing by  $\sqrt{3}$ . The result is a standard uncertainty of,  $u_{TC} = \underline{2.3^\circ\text{C}}$ .

The second scenario is identical to the first, with the exception that there is a temperature gradient between the ends of the extension wire. In this case, the error associated with the extension wire must be considered. This is accomplished by combining the errors from the thermocouple wire and extension wire in quadrature:

$$u_c(T) = \sqrt{u_{TC}^2 + u_{EX}^2} \quad (1.1)$$

Where  $u_c(T)$  is the combined standard uncertainty, and  $u_{TC}$  and  $u_{EX}$  are, respectively, the standard uncertainties of the thermocouple wire and extension wire. Assuming that the extension wire is standard grade, the standard uncertainty is  $u_{EX} = \underline{1.27^\circ\text{C}}$ . The combined standard uncertainty is then,  $u_c(T) = \underline{2.64^\circ\text{C}}$ .

## **INSERTION ERROR**

Insertion errors are those that arise from differences between the thermocouple junction temperature and the temperature of the surrounding fluid. The two types of errors considered are conduction errors and radiation errors.

### **Conduction Error**

Conduction error, as the name suggests, results when heat is conducted away from the thermocouple junction through the wire, causing a reduction in the junction temperature. Conduction errors are minimized by using small gauge wire and relatively long insertion lengths. For wire diameter,  $D$ , and insertion length,  $L$ , a general rule is that conduction errors can be neglected in conditions for which  $L/D > 50$  [3]. Considering 24 AWG wire with a diameter of 0.5 mm, the corresponding minimum insertion length is 2.5 cm.

### **Radiation Error**

In fire environments, radiation error can be significant. Radiation error can be quantified by considering a thermocouple junction in a fluid environment that exchanges energy through convection with the local medium and through thermal radiation with the surroundings. A First Law analysis simplifies to:

$$T_g - T_j = \frac{\epsilon\sigma}{h_c} (T_j^4 - T_s^4) \quad (1.2)$$



ATF-LS-FRL-LI001 Thermocouple	ID: 1587 Revision: 3
Authority: Technical Leader	Page: 5 of 10
Original maintained by Quality Programs; copies are uncontrolled.	

Where  $T_g$  is the gas temperature,  $T_j$  is the junction temperature,  $T_s$  is the temperature of the surroundings,  $\varepsilon$  is the probe emissivity,  $\sigma$  is Boltzmann's constant and  $h_c$  is the convective heat transfer coefficient [4]. The left hand side of Eqn. 1.2 is the difference between the gas temperature and the junction temperature, which represents the error. This error is highly dependent on the conditions of a particular experiment. In conditions where the gas and surrounding temperature are in equilibrium, the net radiant exchange is zero and the radiation error is eliminated. Fire experiments tend to be highly transient, particularly in the developing stage, and the  $T^4$  dependence in the radiation term can drive significant errors in the temperature measurement.

The largest errors are encountered with thermocouples in low temperature regions that are exposed to an intense radiant flux. This is a condition often encountered in a developing enclosure fire in which cool air is drawn into a compartment through the lower area of a door and a sooty, hot upper layer is developing below the ceiling. Radiation from the hot upper layer heats the thermocouple junction, resulting in temperature readings that can be significantly higher than the actual temperature of the gases in the lower layer. One study documented errors as high as 225°C in extreme cases [4].

Radiation errors are greatest in the lower region where the gas temperature is lower than the temperature of the surroundings. The error decreases with a reduction in the temperature of the surroundings and as the gas temperature increases. Errors are typically reduced in the upper layer where gas temperatures are higher than the temperature of the surroundings. However, even in the upper layer, errors can be on the order of 25% [4]. Figure 1 shows a chart of calculated radiation errors for a range of conditions assuming an idealized bare bead thermocouple with a diameter of 1.5 mm [4].

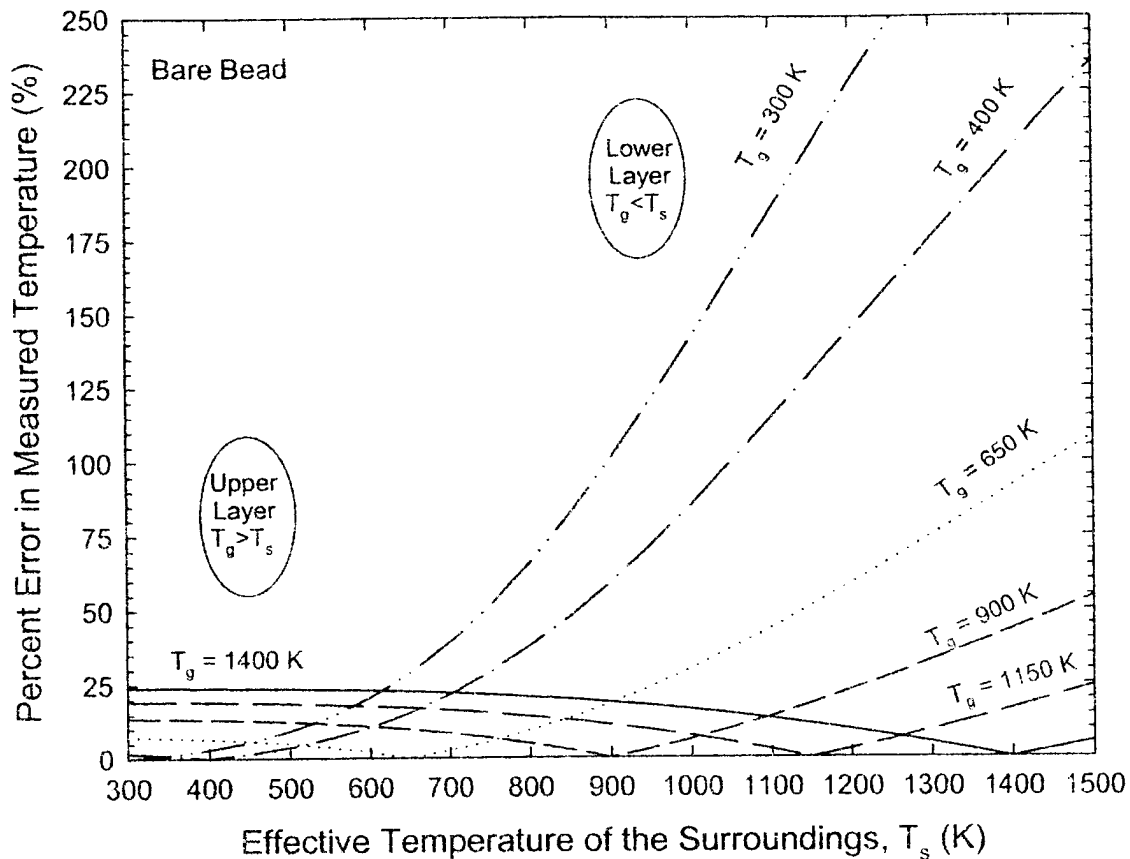

Figure 2: Calculated percentage errors for an idealized bare-bead thermocouple with 1.5 mm diameter bead [4].

## Operating Instructions

### REQUIREMENTS

1. The assigned operator shall be qualified in accordance with laboratory proficiency requirements.
2. The data acquisition instrumentation shall be calibrated and be marked with the calibration status in accordance with FRL calibration procedures.
3. All thermocouples shall be constructed from thermocouple wire with a minimum accuracy of the greater of 1.1°C or 0.4% of the temperature reading over 0°C.
  - 3.1. Exception: When there is a specific experiment requirement for a different level of accuracy, the actual measured thermocouple accuracy shall be documented in the “TC Type” parameter in FireTOSS laboratory report.
4. If thermocouple extension wire is used, the wire shall be used in the range specified.



ATF-LS-FRL-LI001 Thermocouple	ID: 1587 Revision: 3
Authority: Technical Leader	Page: 7 of 10
Original maintained by Quality Programs; copies are uncontrolled.	

- 4.1. The minimum accuracy of Type-K extension wire shall be 2.1 C between 0 °C and 200 °C.
- 4.2. The temperature gradient between the ends of the extension wire and any additional junctions shall be minimized.

## **PROCEDURE**

### **1. Prior to the first test in a series**

- 1.1. Operation of the thermocouples shall be verified in two ways.
  - 1.1.1. The thermocouple reading shall be verified against ambient temperature
  - 1.1.2. A heat source shall be applied and the resulting rise in temperature verified.

### **2. Before each test in a series**

- 2.1. The thermocouple reading shall be verified against ambient temperature to ensure operability.

### **3. During the Test**

- 3.1. The output of the thermocouple shall be recorded for the duration of the experiment.
  - 3.1.1. Exception – When the thermocouple must be removed prior to the end of the experiment due to experiment design or damage. The elapsed time at which the thermocouple was removed and the reason for removal shall be recorded.

### **4. Post Test**

- 4.1. After the experiment, the thermocouples in locations where they could have been damaged shall be examined for visible damage. Perform functional verification if necessary.
  - 4.1.1. If damage has occurred, the instrument shall be taken out of service at the time of the damage. The laboratory engineer shall review the data to determine if there is a noticeable event that marked the damage to the instrument. If not, the thermocouple shall be taken out of service for the entire test. After the thermocouple has been taken out of service, the calculations shall be redone.

Figure 3 shows a flowchart of the procedure that should be used for thermocouples.



ATF-LS-FRL-LI001 Thermocouple	ID: 1587 Revision: 3
Authority: Technical Leader	Page: 8 of 10
Original maintained by Quality Programs; copies are uncontrolled.	

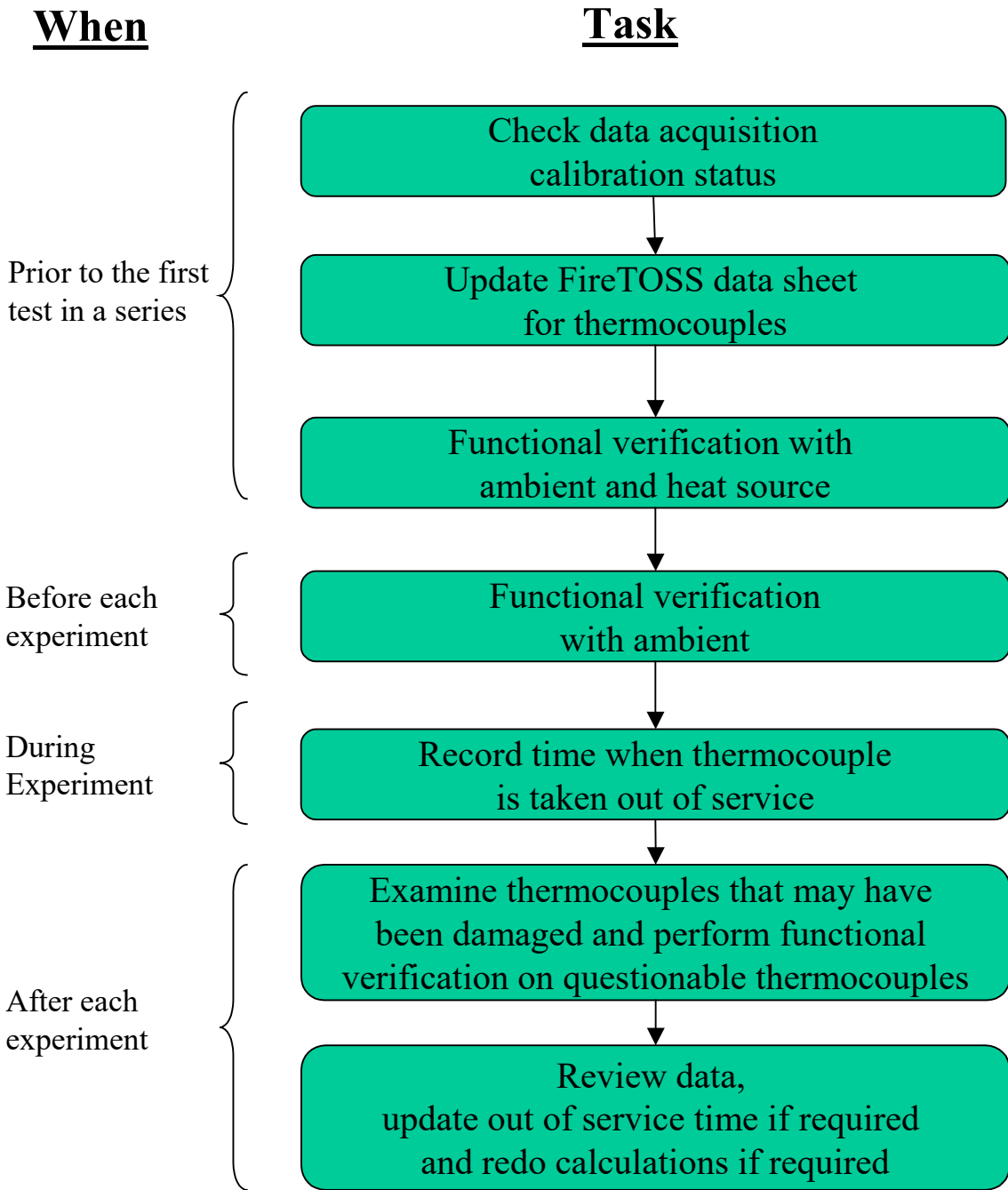

Figure 3. Thermocouple Process Flow Chart



ATF-LS-FRL-LI001 Thermocouple	ID: 1587 Revision: 3
Authority: Technical Leader	Page: 9 of 10
Original maintained by Quality Programs; copies are uncontrolled.	

## Thermocouple Documentation Requirements

Thermocouples shall be documented using the FireTOSS experiment design program. The information that the user can document about the thermocouples is shown in Table 1. The first column in Table 1 shows the description of input parameter that will appear in the column heading of the FireTOSS experiment design program. The second column in Table 1 shows whether the parameter is required in all cases, and column three provides a description of the information to be supplied for the parameter.

**Table 1. Data Acquisition Input Parameters**

Parameter	Required	Parameter Description
Description	True	Description of the location of the thermocouple
Location X	False	X axis location of thermocouple
Location Y	False	Y axis location of thermocouple
Location z	False	Z axis location of thermocouple
TC Type	True	Identifies the type of thermocouple. Required information includes, thermocouple type, diameter, Inconel or beaded, grounded or ungrounded. Thermocouple accuracy shall be documented if required by the design of the experiment or if the accuracy is less than the FRL standard. Also, indicate if TC extension wire was used.
Tree ID	False	In conjunction with a diagram of the experiment set-up, this parameter is used to identify a horizontal or vertical traverse of instruments.
Room Number	False	Cross reference of instrument location
Chart	False	Allows the user to group instrument data onto different charts. If this parameter is left empty, data for similar instruments will be put on one chart.
Out of service time	False	Indicates the elapsed test time that the instrument was removed from the test. All calculations for the data on the instrument cease at this time.
Out of service reason	False	Specifies the reason that the instrument was removed from the experiment. Reasons typically include damage, impending damage, or test design
Initial Change Amount	False	Used in standardized testing to mark an event
Discontinuity threshold value	False	Value used to mark a discontinuity in the data. Typically, an data acquisition error has occurred.



ATF-LS-FRL-LI001 Thermocouple	ID: 1587 Revision: 3
Authority: Technical Leader	Page: 10 of 10
Original maintained by Quality Programs; copies are uncontrolled.	

## References

1. Omega Temperature Measurement Handbook, 6<sup>th</sup> edition, Omega Engineering, Stamford, CT, 2007.
2. Nakos, J. T., "Uncertainty Analysis of Thermocouple Measurements Used in Normal and Abnormal Thermal Environment Experiments at Sandia's Radiant Heat Facility and Lurance Canyon Burn Site," SAND2004-1023, Sandia National Laboratories, Albuquerque, NM, 2004.
3. Figliola, R. S., and Beasley, D. E., *Theory and Design for Mechanical Measurements, Second Edition*, John Wiley and Sons, New York, 1995.
4. Pitts, W. M., Braun, E., Peacock, R. D., Mitler, H. E., Johnsson, E. L., Reneke, P. A., and Blevins, L. G., "Temperature Uncertainties for Bare Bead and Aspirated Thermocouple Measurements in Fire Environments," *Thermal Measurements: The Foundation of Fire Standards*, ASTM STP 1427, L. A. Gritzo and N. J. Alvares, Eds., ASTM International, West Conshohocken, PA, 2002.



ATF-LS-FRL-LI002 Heat Flux Transducer	ID: 1575 Revision: 3
Authority: Technical Leader	Page: 1 of 6
Original maintained by Quality Programs; copies are uncontrolled.	

## Scope

This laboratory instruction covers the use of Schmidt-Boelter Heat Flux Transducers in FRL custom experiments.

## Instrument Description

### GENERAL

A heat flux transducer is a device that measures the rate of absorbed incident energy, and expresses it on a per unit area basis. The operating principle of most heat flux transducers is based on one-dimensional heat conduction through a solid. Temperature sensors are placed on a thin, thermally conductive sensor element, and applying heat establishes a temperature gradient across the element. The heat flux is proportional to the temperature difference across the element according to Fourier's Law.

There are many configurations of heat flux transducers, but for fire applications the choice revolves around five decisions: (1) type, (2) range, (3) size, (4) mode and (5) cooling.

Transducer Type: Two primary types of transducers in use are circular foil (Gardon) and thermopile (Schmidt-Boelter). Schmidt-Boelter transducers are recognized as being the most appropriate for fire applications.

In a Schmidt-Boelter transducer, a constantan wire is wrapped around an electrically insulating sensor element and the turns on one side are plated with copper, producing (T-type) thermocouple junctions on both faces of the sensor [1,2]. The number of thermocouple junctions determines the sensitivity, as there is an additive effect of the potential for each junction.

The time constant of a heat flux transducer is the time required for the sensor to reach 62.5 % of a step input. Time constants vary based on sensor range, however for Schmidt-Boelter transducers they are typically less than 250 milliseconds [3].

Range: The range of a heat flux transducer is determined by the sensitivity of the element to an applied heat flux. Transducers are typically designed to provide a signal of nominally 10 mV at the range peak. Heat flux transducers are classified according to the peak flux for which they are calibrated to read. For Schmidt-Boelter transducers, standard ranges vary from 2 kW/m<sup>2</sup> – 50 kW/m<sup>2</sup>, however ranges as high as 1100 kW/m<sup>2</sup> are available. In fire applications, a range from 25 kW/m<sup>2</sup> – 150 kW/m<sup>2</sup> will cover most applications. Sensors have an over range capability of up to 150 % of the peak specified heat flux [3].

Size: The size of transducer that is appropriate for use depends on the application. A typical size that is used in fire applications is a 2.5 cm (1 in.) diameter body with a 1 cm (3/8 in.) diameter sensor. When finer spatial resolution is required, 1.3 cm (1/2 in.) or 3 mm (1/8 in.) transducers can be used.



ATF-LS-FRL-LI002 Heat Flux Transducer	ID: 1575 Revision: 3
Authority: Technical Leader	Page: 2 of 6
Original maintained by Quality Programs; copies are uncontrolled.	

Transducer Mode: Transducers are designed for use as radiometers to measure the radiative flux, or as total flux transducers in which the sum of radiative and convective components are measured. A radiometer isolates the radiative component by placing an IR-transmitting window in front of the sensor element, eliminating the effect of convective heat transfer on the sensor. Some transducers use two sensors, a total heat flux sensor and a radiometer so that the magnitude of the individual components can be determined. Care must be taken, as window materials do not transmit 100% throughout the IR spectrum. The FRL uses Zinc Selenide window material, as it provides a relatively high and consistent transmittance throughout the relevant spectral range.

Transducer cooling: Some transducers come equipped with the capability for water cooling. In this configuration, water flows through the transducer, removing heat from the backside of the sensor. Water-cooling is recommended for conditions in which the temperature of an uncooled transducer will exceed 204°C (400°F) [3].

## **UNCERTAINTY AND ACCURACY**

The uncertainty of the heat flux measurement has two parts: the uncertainty of the instrument and the uncertainty associated with fluctuations over time. The uncertainty in the instrument is a function of the linearity, repeatability and calibration of the instrument. The combined uncertainty of the measurement is estimated by combining the standard uncertainty of each component in quadrature.

Medtherm gives the linearity of the heat flux transducer as  $\pm 2\%$  full scale [3]. The repeatability is listed as  $\pm 0.5\%$  and the calibration uncertainty is  $\pm 2\%$  for ranges up to 3000 kW/m<sup>2</sup>. It can be assumed that these errors have a rectangular probability distribution, in which case the standard uncertainty is computed by dividing each component by  $\sqrt{3}$  [4]. For a 50 kW/m<sup>2</sup> transducer, the standard uncertainties of these components are then, respectively, 0.58 kW/m<sup>2</sup>, 0.14 kW/m<sup>2</sup>, and 0.58 kW/m<sup>2</sup>.

The uncertainty over time can be calculated using a sample standard deviation. NIST [4] states that for a sample of data, the uncertainty of the samples is:

$$U_s = \sigma / \sqrt{n}$$

where:

- $U_s$  = Standard uncertainty of the samples
- $\sigma$  = Standard deviation of the samples
- $n$  = Number of samples



ATF-LS-FRL-LI002 Heat Flux Transducer	ID: 1575 Revision: 3
Authority: Technical Leader	Page: 3 of 6
Original maintained by Quality Programs; copies are uncontrolled.	

Using this formula, the uncertainty of the heat flux can be determined. Over a sample of 40 data points, the standard deviation was 0.227 kW/m<sup>2</sup>, which yields a standard uncertainty of 0.036 kW/m<sup>2</sup>.

The uncertainty components are combined in quadrature to estimate the combined uncertainty of the heat flux measurement. The result is  $U_{HF} = u(SG_{NG}) = \underline{0.83 \text{ kW/m}^2}$ . For a 50 kW/m<sup>2</sup> transducer this is equivalent to  $\pm 1.7 \%$

## Operating Instructions

### REQUIREMENTS

1. The assigned operator shall be qualified in accordance with laboratory proficiency requirements.
2. The data acquisition equipment shall be calibrated and be marked with the calibration status in accordance with FRL calibration procedures.
3. Heat flux transducers shall be calibrated and be marked with the calibration status in accordance with FRL calibration procedures.
4. Transducers size, range and mode shall be selected to represent the test conditions.

### PROCEDURE

#### 1. Set up

- 1.1. The calibration marking on the transducer shall be checked to confirm that the instrument is calibrated.
- 1.2. Transducers shall be connected to the data acquisition hardware using the smallest voltage input range that will bound the output range of the transducer. This is usually the 20 mV range.
- 1.3. All heat flux transducers shall be connected to a constant temperature flowing water source.
- 1.4. Water lines and wires connected to the heat flux transducer shall be protected if it is anticipated that they will be exposed to excessive heat during the experiment.

#### 2. Pre-Test

- 2.1. It shall be verified that water is flowing through each transducer.
- 2.2. The water temperature used to cool the transducer shall be a minimum of 5°C above ambient. This temperature shall be recorded on the data sheet.
- 2.3. A baseline reading shall be recorded with the transducer prior to conducting experiments. The baseline value shall be the average heat flux measured during a period with a minimum 2-minute duration.
- 2.4. During the baseline reading, the water temperature will be stable.



ATF-LS-FRL-LI002 Heat Flux Transducer	ID: 1575 Revision: 3
Authority: Technical Leader	Page: 4 of 6
Original maintained by Quality Programs; copies are uncontrolled.	

### 3. Test

- 3.1. Water shall be supplied continuously at the required temperature.
- 3.2. The output of the heat flux transducer shall be recorded for the duration of the experiment.
- 3.3. Exception – When the heat flux transducer must be removed prior to the end of the experiment due to experiment design or impending damage to the instrument. The elapsed time at which the transducer was removed and the reason for instrument removal shall be recorded on the data sheet.

### 4. Post Test

- 4.1. After the experiment, heat flux transducers in areas where they may have been damaged shall be examined for visible damage or surface dirt.
- 4.2. If damage or surface dirt is observed the instrument shall be cleaned and/or repaired according to manufacturer’s documentation.
- 4.3. If the heat flux exceeded 150% of the maximum transducer range during any point of a test, the instrument shall be taken out of service until its correct operating condition is confirmed.

## Heat Flux Transducer Documentation Requirements

Heat flux transducer usage shall be documented using the FireTOSS experiment design program. The information that the user shall document about the heat flux transducers is shown in Table 1. The first column in Table 1 shows the description of input parameter that will appear in the column heading of the FireTOSS experiment design program. The second column in Table 1 shows whether the parameter is required in all cases, and column three provides a description of the information to be supplied for the parameter.

**Table 1: Data Acquisition Input Parameters**

Parameter	Required	Parameter Description
Calibration Factors	True	(m, b) Taken directly from the calibration data sheet or sticker.
Description	True	Description of the location of the heat flux transducer or a description of what it is pointing at.
Location – X	False	X – Location of transducer based on defined coordinate system (m)
Location – Y	False	Y – Location of transducer based on defined coordinate system (m)
Location – Z	False	Z – Location of transducer based on defined coordinate system (m)
Orientation	False	Orientation of transducer based on defined coordinate system
Room Number	False	Identification of transducer location in a compartment
Type	True	Description of transducer type.
Range	True	Peak range (kW/m <sup>2</sup> )
OverRange	False	
Mode	True	Total or Radiative
Serial number	True	Manufacturer’s serial number
Status	True	
Bar code	True	FRL Equipment identification number (asset number)
Path length	False	Distance in meters from the measuring surface of the flux transducer to the item of interest. A diagram of the test set up typically supports this



ATF-LS-FRL-LI002 Heat Flux Transducer	ID: 1575 Revision: 3
Authority: Technical Leader	Page: 5 of 6
Original maintained by Quality Programs; copies are uncontrolled.	

Parameter	Required	Parameter Description
		measurement.
Water temperature	True	Temperature of the cooling water supplied to the heat flux transducer
Chart	False	Allows the user to group instrument data onto different charts. If this parameter is left empty, data for similar instruments will be put on one chart.
Baseline Experiment ID	False	Experiment ID where baseline data is stored for a particular instrument.
Baseline Heat Flux	False	Offset applied to heat flux readings to account for measured background heat flux due to the cooling water. If a value for the 'Baseline Experiment ID' is input in the data sheet this value will be automatically inserted from the calculated 'Average Uncorrected Heat Flux' otherwise the user input value will be used. (kW/m <sup>2</sup> )
Out of service time	False	Indicates the elapsed test time that the instrument was removed from the test. All calculations for the data on the instrument cease at this time.
Out of service reason	False	Specifies the reason that the instrument was removed from the experiment. Reasons typically include damage, impending damage, or test design

## List of Standards

The following standards apply to the use of heat flux transducers.

ISO/TS 14934-1:2010 “Fire tests -- Calibration and use of heat flux meters -- Part 1: General principles”

ISO/TS 14934-2:2006 “Fire tests -- Calibration and use of heat flux meters – Part 2: Primary calibration methods

ISO/TS 14934-3:2006 “Fire tests -- Calibration and use of heat flux meters – Part 3: Secondary calibration method

ISO/TS 14934-4:2007 “Fire tests -- Calibration and use of heat flux meters – Part 3: Guidance on the use of heat flux meters in fire tests

## References

1. Barnes, A., “Heat Flux Sensors Part 1: Theory,” Sensors, January 1999.
2. Technical Data Sheet, “Schmidt-Boelter Heat Flux Sensor,” Vatel Corporation, [www.vatell.com/SB.htm](http://www.vatell.com/SB.htm)
3. Medtherm Corporation, Technical Data Sheet.



ATF-LS-FRL-LI002 Heat Flux Transducer	ID: 1575 Revision: 3
Authority: Technical Leader	Page: 6 of 6
Original maintained by Quality Programs; copies are uncontrolled.	

4. Taylor, B. N., & Kuyatt, C. E., "NIST Technical Note 1297: Guidelines for Evaluating and Expressing the Uncertainty of NIST Measurement Results," National Institute of Standards and Technology, Gaithersburg, MD 1993.
5. Bryant, A.R., Ohlemiller, T.J., Johnsson, E.L, Hamins, A., Grove, B.S., Guthrie, W.F., Maranghides, A., Mulholland, G.W., "Special Publication 1007," National Institute of Standards and Technology, Gaithersburg, MD 2003.
6. Guthrie, W. & Liu, H., "Hands-on Workshop on Estimating and Reporting Measurement Uncertainty," National Institute of Standards and Technology, Presentation given to CPSC, 2007.



ATF-LS-FRL-LI003 Digital Cameras	ID: 1574 Revision: 4
Authority: Technical Leader	Page: 1 of 6
Original maintained by Quality Programs; copies are uncontrolled.	

## Scope

This instruction covers the use of digital cameras for experiments at the Bureau of Alcohol, Tobacco, Firearms and Explosives (ATF) Fire Research Laboratory (FRL).

## Instrument Description

### **GENERAL**

Digital Cameras are used within the FRL to record digital still photographs during experiments. The following gives a brief description of the factors effecting digital camera image quality. [ 1 ]

### Pixels

Though a digital photograph looks smooth and continuous just like a regular photograph, it's actually composed of millions of tiny squares called pixels.

Each pixel in an image has a numerical value and is made up of three color channels with values ranging from 0 to 255. Each color in this scheme can be represented by an 8-bit number (byte), so the color of each pixel is defined by three color bytes.

### Aspect Ratio

The aspect ratio of a camera is the ratio of the length of the sides of the images. For example, a 35 mm film frame is approximately 36 mm wide and 24 mm high which equates to an aspect ratio of 3:2. Most digital SLR (single lens reflex) cameras use the same aspect ratio for their digital images. However, video monitors typically use a 4:3 aspect ratio and most consumer level digital cameras use a 4:3 aspect ratio for their images.

### Sensor Size

A 35mm film frame is 24 mm high by 36 mm wide but most digital cameras use sensors much smaller than this. For a given pixel count, the larger the sensor, the better the image quality and the lower the noise level.

### White Balance

With digital you can pick your white balance to suit your light source, so that white looks white, not yellow or blue. Normally there is an automatic setting and the camera decides what white balance setting to use. However if you know what your light source is you can usually set the camera to it and this may give better results. Most digital cameras have settings for sunlight, shade, electronic flash, fluorescent lighting and tungsten lighting. Some have a manual or custom setting where you point the camera at a white card and let the camera figure out what setting to use to make it white.



ATF-LS-FRL-LI003 Digital Cameras	ID: 1574 Revision: 4
Authority: Technical Leader	Page: 2 of 6
Original maintained by Quality Programs; copies are uncontrolled.	

## Sensitivity

Sensitivity settings on digital cameras are the equivalent of ISO ratings on film. Most digital cameras will have settings with a sensitivity equivalent to ISO 100 film and ISO 200 film. Many will have an ISO 400 setting, but above that the images from cameras with small sensors gets noisy. The more expensive digital SLRs with much larger sensors have higher sensitivity settings. At ISO 400 they are virtually noise free and some can go as high as ISO 3200. Very few cameras have ISO setting lower than ISO 100 because noise levels are so low at ISO 100 there would be no real advantage in a slower setting. Quite a few digital cameras have an "auto" ISO setting, where the camera will pick the ISO setting depending on the light level and the mode in which the camera is operating.

## Digital Zoom and Optical Zoom

Most cameras have both optical zoom and digital zoom. Optical zoom works just like a zoom lens on a film camera. The lens changes focal length and magnification as it is zoomed. Image quality stays high throughout the zoom range. Digital zoom simply crops the image to a smaller size, then enlarges the cropped portion to fill the frame again. Digital zoom results in a significant loss of quality.

## JPEG, TIFF and RAW

The size of the digital file corresponding to the image which the camera produces depends on the pixel count. In most digital cameras each pixel generates 3 bytes of data (so called "8-bit data"). This means that a 3 MP camera generates 9 MB per image. A few cameras can generate extra data for extra quality, and some of these cameras generate files which correspond to 2 bytes of data for each color ("16-bit"), so a 3 MP camera which is capable of generating 16-bit data will produce an 18 MB image file.

JPEG (Joint Photo Experts Group) is an algorithm designed to work with continuous tone photographic images that takes image data and compresses it in a lossy manner. The more you compress, the smaller the file but the more information you lose. However, you can reduce file size by a factor of 10 or more and still get a very high quality image, just about as good as the uncompressed image for most purposes.

There are also lossless ways of saving files using TIFF (Tagged Image File Format) . These keep all the original information, but at the cost of much bigger files. TIFF files can be compressed in a non-lossy way, but they don't get very much smaller.

Some cameras can save the actual data generated by the sensor in a proprietary format. Nikon calls these files "NEF". These files are compressed, but in a non-lossy manner. They are significantly smaller than equivalent TIFF files, but larger than JPEGs. Typically they achieve a compression of around 6:1 using 16-bit data, so files are 1/6 the size of equivalent TIFF files. The disadvantage of these formats is that the image must be converted to either JPEG or TIFF



ATF-LS-FRL-LI003 Digital Cameras	ID: 1574 Revision: 4
Authority: Technical Leader	Page: 3 of 6
Original maintained by Quality Programs; copies are uncontrolled.	

for most software to be able to display them. Since NEF formats contain more information than JPEGs, some degree of exposure compensation and white balance corrections can be done.

## Uncertainty and Accuracy

The accuracy requirement for the clock on the digital camera is 1 second over a 24 hour period. In addition, before taking the first picture of a test series each day, the clock on the camera must be synchronized with the clock on the data acquisition computer.

### **SYNCHRONIZING CAMERA CLOCKS**

FireTOSS uses the date and time embedded in the digital picture file to determine the time that the photo was taken in relation to the start of the experiment. For this reason, the digital camera's date and time must be set to the same date and time as the computer taking the data. The process of setting the date and time on the camera to be the same as the date and time on the computer is called synchronizing the camera clock.

Nikon Transfer 2 software is used to synchronize the camera clock to the computer clock, which is in turn regulated by the secure FireTOSS database. The camera must be connected to the computer via USB cable to use this synchronization method. This is the preferred method of camera synchronization.

If the previous method is not possible, a second, manual method of synchronization is possible. To synchronize the camera manually, the user must open the computer clock program and the camera date/time menu and manually set the camera time to the computer time.

## Operating Instructions

### **REQUIREMENTS**

1. Digital cameras used for laboratory experiments shall be capable of having their clocks synchronized with the data acquisition system
2. The photographer shall be proficient with the camera.
3. Digital photographs shall be uploaded into FireTOSS immediately after the conclusion of each test or immediately after completion of post-test photographs are taken, where applicable.

### **PROCEDURE**

1. **Prior to taking the first test picture of the day**
  - a. Check camera battery status.
  - b. The digital camera clock shall be synchronized with the data acquisition system before the first test of the day.



ATF-LS-FRL-LI003 Digital Cameras	ID: 1574 Revision: 4
Authority: Technical Leader	Page: 4 of 6
Original maintained by Quality Programs; copies are uncontrolled.	

- 2. **During experiment**
  - a. Take photographs
- 3. **At the conclusion of each test**
  - a. Digital photographs shall be uploaded to the data acquisition system.

Figure 1 shows a flowchart of the procedure that should be used for digital cameras.

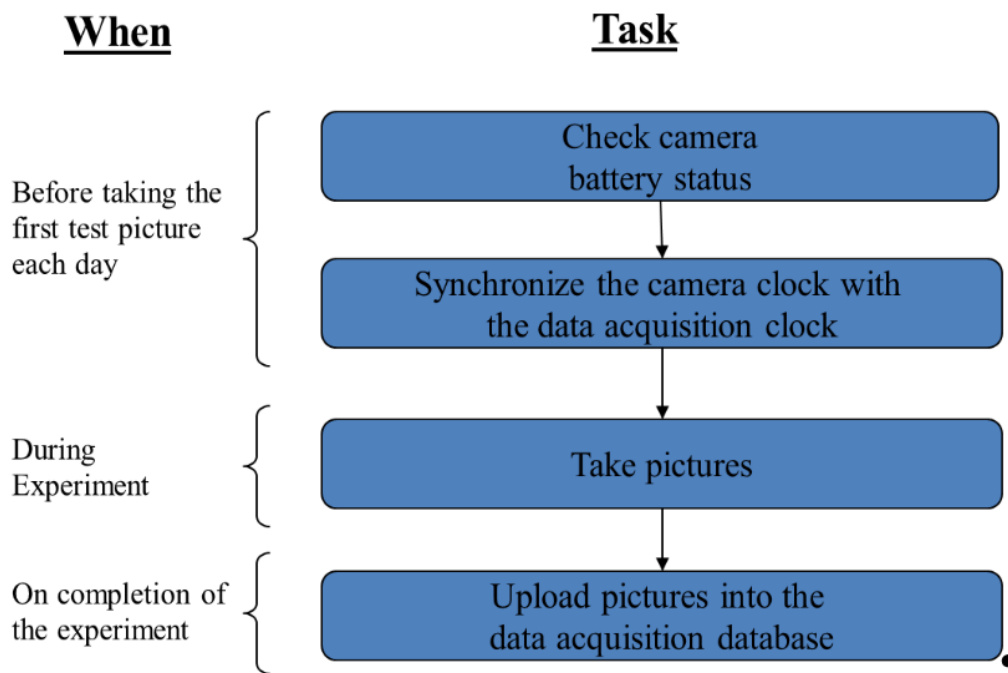

**Figure 1. Digital Camera Process Flow Chart**

### Digital Camera Documentation Requirements

Digital photographs taken during an experiment shall be documented using the FireTOSS experiment design program. The required information that the user must document when using the digital camera in an experiment is shown in Table 1. The first column provides the input parameter and the second column provides a brief description of that parameter. The third column lists whether the parameter is required in all cases. The fourth column lists how the parameter is entered into the FireTOSS design program.



ATF-LS-FRL-LI003 Digital Cameras	ID: 1574 Revision: 4
Authority: Technical Leader	Page: 5 of 6
Original maintained by Quality Programs; copies are uncontrolled.	

**Table 1. Data Acquisition Input Parameters**

Parameter	Parameter Description	Required	Input Method
Description	Description of what the image shows	FALSE	User
Cleared for General Public	All requirements have been met to share this for public dissemination.	FALSE	User
Picture poster status	Usually, many pictures are taken during an experiment. This parameter is used to identify pictures that are the best representation of a test.	FALSE	User
Use in report	Determines whether the image will be inserted into the default test record document. This option is often used to choose the best image out of a series images taken of the same subject with different camera settings.	FALSE	User
File Upload Verified	Indicates that the existence of the file in the archive has been verified.	TRUE	Automatic
Picture test time	The elapsed time from the start of the experiment	FALSE	Automatic
Photographer	Identification of the person that took the picture.	TRUE	User
Upload date time	Date and time when the file was uploaded into FireTOSS	TRUE	Automatic
Synchronized with FireTOSS	Specifies if the camera had been synchronized to the data acquisition system	TRUE	User
Original file date	Date of the file that was uploaded into the archive. This date is taken from the file system of the device from which the file was uploaded.	TRUE	Automatic
Time Offset	The time difference between the camera clock and the data acquisition clock	FALSE	User
Time Offset Units		FALSE	User
Filename	#####	TRUE	Automatic
Thumbnail file name	Name of the low resolution picture file stored in the archive	FALSE	Automatic
File Size	Specifies the size of the file. This value is automatically calculated by the FireTOSS upload programs.	FALSE	Automatic
Original file name	File name of the file that was uploaded into the data acquisition system. This file name is taken from the file system of the device from which the file was uploaded.	TRUE	Automatic
Use on web	Determines whether the image will be inserted into the default web page for the experiment.	FALSE	User
File Path	Alternate location for files not stored in the default archive location	FALSE	User



ATF-LS-FRL-LI003 Digital Cameras	ID: 1574 Revision: 4
Authority: Technical Leader	Page: 6 of 6
Original maintained by Quality Programs; copies are uncontrolled.	

## References

1. "D90 User's Manual," Nikon, 2008.



ATF-LS-FRL-LI007 Stopwatch	ID: 1585 Revision: 3
Authority: Technical Leader	Page: 1 of 2
Original maintained by Quality Programs; copies are uncontrolled.	

## Scope

This instruction covers the use of stopwatches used by the Bureau of Alcohol, Tobacco, Firearms and Explosives (ATF) Fire Research Laboratory (FRL) Examiners.

## Instrument Description

### **GENERAL**

A stopwatch is a manually operated device that measures and displays the duration of a specific event or test. Though many stopwatches contain additional functions, the functions primarily utilized by FRL Examiners are the start, stop, and reset functions on the stopwatch. Refer to the stopwatch manufacturer's documentation for detailed information concerning additional stopwatch functions.

## Accuracy Requirements

FRL stopwatches are required to maintain time with a loss of no more than 1 second over a 1 hour period. This results in an accuracy of 0.028%. The stopwatches shall be functionally verified in accordance with FRL Stopwatch Functional Verification Procedures.

## Operating Instructions

### **REQUIREMENTS**

1. The assigned operator shall be qualified in accordance with laboratory proficiency requirements.
2. The assigned operator shall verify the functionality of the stopwatch prior to testing

### **PROCEDURE**

The following is a general procedure for operation of a stopwatch.

#### **1. Set up**

- 1.1 Ensure that stopwatch has been functionally verified

#### **2. Pre-Test**

- 2.1 Ensure that operator is familiar with test procedures to ensure appropriate stopwatch operation.

#### **3. Test**

- 3.1 Operate the stopwatch in accordance with the test examiner's specifications.
- 3.2 The operability of the stopwatch shall be monitored during the test. If the stopwatch operation is in question, verify the functionality of the stopwatch before continuing use in a test.



ATF-LS-FRL-LI007 Stopwatch	ID: 1585 Revision: 3
Authority: Technical Leader	Page: 2 of 2
Original maintained by Quality Programs; copies are uncontrolled.	

#### **4. Post Test**

4.1 If testing is complete, reset the time displayed on the stopwatch.

### **Stopwatch Documentation Requirements**

None

### **References**

None



ATF-LS-FRL-LI009 Velocity - Differential Pressure	ID: 1591 Revision: 3
Authority: Technical Leader	Page: 1 of 8
Original maintained by Quality Programs; copies are uncontrolled.	

## Scope

This laboratory instruction covers the use of differential pressure probes for velocity measurements in FRL experiments.

## Instrument Description

### *GENERAL*

Velocity measurements can be separated into two categories: external and internal. External velocity measurements are generally point measurements conducted in the open or near a surface. Internal velocity measurements are conducted inside pipes or ducts where the total volumetric flow rate is an important parameter. Internal velocity measurements can be performed at individual points within a pipe or duct, in which case the flow rate can be determined if the velocity profile is known. Alternatively, the average internal velocity can be measured using a probe with an array of pressure taps spaced at precise locations throughout a cross section of the duct.

### Point Measurements

For point measurements in fire applications two common probe types are Pitot static tubes and bidirectional probes. Pitot static tubes are the standard probe used for many velocity measurements in clean flow environments where the direction of flow is known and consistent. Bi-directional probes, as the name suggests, can be used to measure flows in two directions and are relatively insensitive to alignment as long as the probe axis is oriented within  $\pm 50$  degrees of the direction of flow [1]. Bidirectional probes can also be used in dirty flow environments because the pressure measuring ports are larger than those in Pitot static tubes and as such are less prone to blockage from the accumulation of soot particles. These features make bidirectional probes well suited for measurements in fire environments. See TR009a for more detailed technical reference regarding point measurements.

### Averaging Measurements

Averaging pressure probes are used for internal measurements and are designed to span the cross section of a pipe or duct. This type of probe is characterized by multiple pressure taps spaced at precise intervals in order to deliver a measurement that represents the average differential pressure for flow in a duct. The advantage of this type of probe is that the average velocity, and hence the flow rate, can be calculated without requiring knowledge of the velocity profile. See TR009b for more detailed technical reference regarding averaging measurements.



ATF-LS-FRL-LI009 Velocity - Differential Pressure	ID: 1591 Revision: 3
Authority: Technical Leader	Page: 2 of 8
Original maintained by Quality Programs; copies are uncontrolled.	

### ***THEORY***

Differential pressure velocity measurements are based upon Bernoulli's Equation [2]:

$$P_1 + \frac{1}{2} \rho V_1^2 + \rho g Z_1 = P_2 + \frac{1}{2} \rho V_2^2 + \rho g Z_2 \quad (1)$$

where P is static pressure,  $\rho$  is density of the flowing fluid, V is velocity, g is acceleration due to gravity, and Z is the elevation. This equation can be applied to two points along a streamline as in Figure 1. If one point is taken upstream of a blunt body, where the velocity is equal to the free stream velocity, and the second point is taken as the stagnation point (where the velocity is reduced to zero), a velocity term in Eqn. (1) can be eliminated.

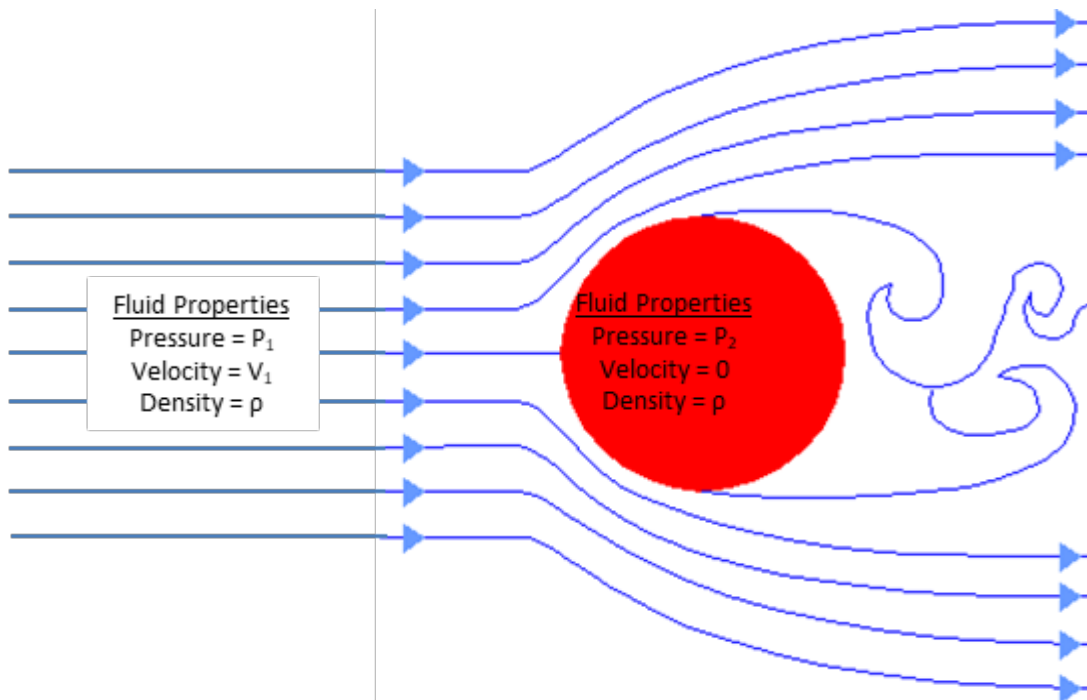

**Figure 1: Flow along a streamline to a stagnation point.**

Further, for a velocity probe, the assumption can be made that pressure induced by elevation difference is negligible. Under these conditions, Eqn. (1) can be reduced to:

$$\Delta P = \frac{1}{2} \rho V^2 \quad (2)$$



ATF-LS-FRL-LI009 Velocity - Differential Pressure	ID: 1591 Revision: 3
Authority: Technical Leader	Page: 3 of 8
Original maintained by Quality Programs; copies are uncontrolled.	

Solving for the velocity as a function of the pressure yields:

$$V = \sqrt{\frac{2\Delta P}{\rho}} \quad (3)$$

## FireTOSS Calculations

### *VELOCITY CALCULATION*

In practice, it is desirable to express velocity in terms of readily measurable quantities such as temperature. For fluids that conform with the ideal gas law, the density,  $\rho$ , at any temperature,  $T$ , can be calculated from the density at a reference temperature as follows:

$$\rho_0 T_0 = \rho T \quad (4)$$

or, rearranging terms:

$$\rho = \frac{\rho_0 T_0}{T} \quad (5)$$

Substituting Eqn. (5) into Eqn. (3) yields:

$$V = \sqrt{\frac{2\Delta P T}{\rho_0 T_0}} \quad (6)$$

or

$$V = C \sqrt{\Delta P T} \quad (7)$$

where  $\Delta P$  is the measured differential pressure,  $T$  is the measured temperature at the velocity probe, and  $C$  is calculated from  $\sqrt{2/\rho_0 T_0}$  where  $T_0$  is the reference temperature and  $\rho_0$  is the fluid density at the reference temperature. The differential pressure measured using a bidirectional probe is slightly greater than the dynamic pressure given in Eqn. (2) and a correction to  $C$  is required. Details associated with this correction can be found elsewhere [3].



ATF-LS-FRL-LI009 Velocity - Differential Pressure	ID: 1591 Revision: 3
Authority: Technical Leader	Page: 4 of 8
Original maintained by Quality Programs; copies are uncontrolled.	

### ***UNCERTAINTY AND ACCURACY***

The velocity uncertainty is a combination of the uncertainty of its components, including temperature, pressure and the correction factor, C, and is given by the following equation [4 - 6]:

$$u_c(V) = \sqrt{\sum s_i^2 u(x_i)^2} \quad (9)$$

where:

- $(V)$  = Combined standard uncertainty of the velocity
- $u(x_i)$  = Standard uncertainty of each velocity component
- $s_i$  = Sensitivity coefficient ( $\partial y / \partial x_i$ )

Applying Eqn. (9) to Eqn. (7) yields:

$$u_c(V) = \left[ \left( \frac{C}{2} \sqrt{\frac{T}{\Delta P}} \right)^2 (u(\Delta P))^2 + \left( \frac{C}{2} \sqrt{\frac{\Delta P}{T}} \right)^2 (u(T))^2 + (\sqrt{\Delta P T})^2 (u(C))^2 \right]^{1/2} \quad (10)$$

where:

- $u(\Delta P)$  = Standard uncertainty of differential pressure
- $u(T)$  = Standard uncertainty of temperature
- $u(C)$  = Standard uncertainty of correction factor

The velocity uncertainty calculated using Eqn. (10) is specific to a given type of probe, instrumentation and experimental configuration. Temperature uncertainty is primarily a function of the temperature sensor. For a thermocouple with special limits of error the accuracy is 1.1°C or 0.4 % [7]. For a bidirectional probe, uncertainty in the value of C is  $\pm 5$  % [1]. Uncertainty in the pressure measurement is a function of several factors, including transducer uncertainty and probe alignment. The stated error of a MKS Baratron pressure transducer is  $\pm 0.15$  % of the reading [8]. The accuracy of a Setra model 267 pressure transducer is  $\pm 0.4$  % of full scale [9]. Probe alignment has a potential for introducing 10 % error in the velocity in extreme cases [1]. A more reasonable estimate of this error is  $\pm 3$  % for alignment within  $\pm 15^\circ$  of the flow direction.

Detailed uncertainty analyses specific to probe – transducer combinations are given in the Technical Reference documents [3,10].



ATF-LS-FRL-LI009 Velocity - Differential Pressure	ID: 1591 Revision: 3
Authority: Technical Leader	Page: 5 of 8
Original maintained by Quality Programs; copies are uncontrolled.	

## Operating Instructions

### ***REQUIREMENTS***

1. The assigned operator shall be qualified in accordance with laboratory proficiency requirements.
2. The data acquisition equipment shall be calibrated and be marked with the calibration status in accordance with FRL calibration procedures.
3. Pressure transducers shall be calibrated and be marked with the calibration status in accordance with FRL calibration procedures.
4. Thermocouples shall be constructed from thermocouple wire with a minimum accuracy of the greater of 1.1°C or 0.4% of the temperature reading over 0°C. If there is a specific experiment requirement for a different level of accuracy, then the actual measured thermocouple accuracy shall be documented in the “TC Type” input field of the data sheet.

### ***PROCEDURE***

#### **1. Set up**

- 1.1. The calibration marking on the pressure transducer shall be checked to confirm that the instrument is calibrated.
- 1.2. Pressure transducers shall be connected to the data acquisition hardware using the smallest voltage input range that will bound the output range of the transducer.
- 1.3. Pressure lines connected to the velocity probe shall be protected if it is anticipated that they will be exposed to excessive heat or pressure during the experiment.
- 1.4. Perform functional verification of:
  - 1.4.1. Thermocouple with ambient and heat source
  - 1.4.2. Pressure transducer with positive pressure source

#### **2. Prior to First Test of Series**

- 2.1. A zero pressure baseline shall be recorded with the pressure transducer prior to conducting experiments. During the baseline reading the high and low pressure ports of the pressure transducer shall be directly connected. The baseline value shall be the average pressure measured during a period with a minimum 2-minute duration.
- 2.2. Following the baseline test, the ports on the pressure transducer shall be opened to each of the two probe fittings.
- 2.3. Verify that the zero pressure baseline has been recorded on the FireTOSS data sheet.

#### **3. Prior to each Test**

- 3.1. Perform functional verification of the pressure transducer and thermocouple with ambient.
- 3.2. Update FireTOSS data sheet.



ATF-LS-FRL-LI009 Velocity - Differential Pressure	ID: 1591 Revision: 3
Authority: Technical Leader	Page: 6 of 8
Original maintained by Quality Programs; copies are uncontrolled.	

#### 4. Test

- 4.1. The output of the pressure transducer and the thermocouple shall be recorded for the duration of the experiment.
- 4.2. When the velocity probe must be removed prior to the end of the experiment due to experiment design or impending damage to the instrument. The elapsed time at which the probe was removed and the reason for instrument removal shall be recorded on the data sheet.

#### 5. Post Test

- 5.1. If an instrument was taken out of service during a test, update the out of service time and out of service reason fields on the FireTOSS data sheet and redo the calculations.
- 5.2. After the experiment, velocity probes located in areas where they may have been damaged shall be examined for visible damage or surface dirt.
- 5.3. If surface dirt is observed, the accumulated soot shall be removed and lines shall be blown out with compressed air. If the probe is physically damaged, it shall be taken out of service until it has been repaired.
- 5.4. If conditions occurred, either during the test or following the test, that could potentially affect the performance of the instrument, a functional verification shall be performed on the pressure transducer and thermocouple.

### Velocity Probe Documentation Requirements

Velocity probe usage shall be documented using the FireTOSS experiment design program. For velocity probes used with a Fire Product Collector (FPC), the required information is automatically entered when the FPC is selected in the FireTOSS experiment design program.

For

The information that the user shall document for external velocity measurements using a velocity probe is shown in Table 1, which is for the . The first column in Table 1 shows the description of input parameter that will appear in the column heading of the FireTOSS experiment design program. The second column in Table 1 shows whether the parameter is required in all cases, and column three provides a description of the information to be supplied for the parameter.



ATF-LS-FRL-LI009 Velocity - Differential Pressure	ID: 1591 Revision: 3
Authority: Technical Leader	Page: 7 of 8
Original maintained by Quality Programs; copies are uncontrolled.	

**Table 1: Data Acquisition Input Parameters**

Parameter	Parameter Description	Required	Input Method
Calibration Status	Automatically updated status of the pressure transducer calibration	True	Automatic
Description	Description of the location of the velocity probe.	True	User
Bar Code	FRL unique identifier for pressure transducer.	True	User
Baseline Experiment	This is the experiment ID number that contains baseline average data for this instrument. If this is specified, and a serial number is entered corresponding to a serial number in the Baseline test, the baseline pressure will be taken from that test.	False	User
Serial Number	The manufacturer provided pressure transducer serial number.	True	Automatic
Velocity Probe Description	Identifies the type of velocity probe. The coefficients used in the velocity calculations are determined by the probe type. Typical probe types are bidirectional and Pitot.	True	User Selectable
Velocity Probe Diameter	For a bidirectional probe this is inner diameter.	True	
Thermocouple Type	Identifies the type of thermocouple. Required information includes, Thermocouple type, diameter, Inconel or beaded, grounded or ungrounded.	True	
Location X	In conjunction with a diagram of the experiment set up, this parameter is used to identify the X location of the instrument.	False	User
Location Y	In conjunction with a diagram of the experiment set up, this parameter is used to identify the Y location of the instrument.	False	User
Location Z	The elevation of the probe in meters. This parameter is recommended for probes within compartments.	False	User
Orientation	Direction probe is facing.	True	User
Time Out of Service	Indicates the elapsed test time that the instrument was removed from the test. All calculations for the data on the instrument cease at this time.	False	User
Out of Service Reason	Specifies the reason that the instrument was removed from the experiment. Reasons typically include damage, impending damage, or test design	False	User
Tree ID	In conjunction with a diagram of the experiment set	False	User



ATF-LS-FRL-LI009 Velocity - Differential Pressure		ID: 1591 Revision: 3
Authority: Technical Leader		Page: 8 of 8
Original maintained by Quality Programs; copies are uncontrolled.		

Parameter	Parameter Description	Required	Input Method
	up this parameter is used to identify a horizontal or vertical traverse of instruments		
Chart	Integer, Allows the user to group instrument data onto different charts. If this parameters is left empty all the charts will contain data for all instruments. A value of -1 indicates that the data will not be shown on a chart.	False	User
Room Number	This is an integer number indicating the room number. It is used as a cross reference for instrument location.	False	User

## References

1. McCaffrey, B.J., and Heskestad, G., "A Robust Bidirectional Low-Velocity Probe for Flame and Fire Applications", *Combustion and Flame*, 26, 125 – 127, 1976.
2. Fox, R. W., and McDonald, A. T., *Introduction to Fluid Mechanics, 3<sup>rd</sup> Edition*, Wiley, 1985.
3. ATF FRL Technical Reference, "TR009a – Differential Pressure – Point Velocity Probes."
4. Taylor, B. N., & Kuyatt, C. E., "NIST Technical Note 1297: Guidelines for Evaluating and Expressing the Uncertainty of NIST Measurement Results," National Institute of Standards and Technology, Gaithersburg, MD 1993.
5. Bryant, A.R., Ohlemiller, T.J., Johnsson, E.L, Hamins, A., Grove, B.S., Guthrie, W.F., Maranghides, A., Mulholland, G.W., "Special Publication 1007," National Institute of Standards and Technology, 2003.
6. Guthrie, W. & Liu, H., "Hands-on Workshop on Estimating and Reporting Measurement Uncertainty," National Institute of Standards and Technology, Presentation given to CPSC, 2007.
7. *The Temperature Handbook*, 2nd edition, Omega Engineering, Stamford, CT, 2000.
8. MKS Baratron Technical Data Sheet.
9. Setra 267 Pressure Transducer, Technical Data Sheet.
10. ATF FRL Technical Reference, "TR009b – Differential Pressure – Averaging Velocity Probes."



ATF-LS-FRL-LI010 Calibration Burners	ID: 1566 Revision: 3
Authority: Technical Leader	Page: 1 of 8
Original maintained by Quality Programs; copies are uncontrolled.	

## Scope

This Laboratory Instruction covers the use of calibration burners used in FRL experiments.

## Instrument Description

### GENERAL

Burners are used in experiments to produce fires of known size and configurations. Burners consist of three main components as shown in Figure 1: a fuel supply, fuel flow monitoring and controlling instrumentation (sometimes referred to as the gas train), and a generic burner. All instrumentation must be calibrated according to manufacturer and ATF specifications.

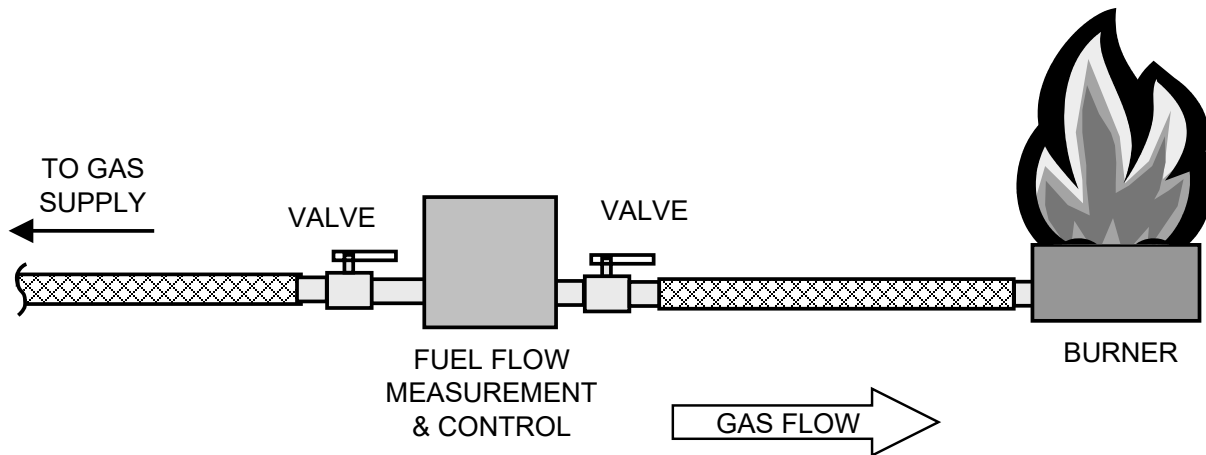

**Figure 1. General Burner Components**

### Fuel

The primary types of fuel used in the ATF FRL are heptane liquid and natural gas, which is composed primarily of methane. Other types of fuel are equally acceptable as long as the proper gas measurement equipment and burners are used. The properties of n-heptane can be taken from relevant literature. Alternatively, properties can be measured using appropriate test methods. The properties of natural gas are calculated by the ATF FRL using a combustion calorimeter [1].

### Gas Train

A gas train consists of a minimum of a flow controller and a flow rate measurement instrument. Gas trains may also contain instrumentation for measuring fluid temperature and pressure as well as various filters and valves.



ATF-LS-FRL-LI010 Calibration Burners	ID: 1566 Revision: 3
Authority: Technical Leader	Page: 2 of 8
Original maintained by Quality Programs; copies are uncontrolled.	

There are several types of flow measurement instruments used for burners. Flow measurement instruments are not universal and must be chosen based upon the type of fuel being used.

Flow rate measurement instruments output flow rates using several different methods.

- 1) The flow rate can be output as an electronic signal that can be monitored by a data acquisition system
- 2) The instrument can have a visual flow rate indicator so that the flow rate must be recorded manually, or
- 3) The flow measurement instrument may have a total flow counter from which the average flow rate can be calculated by dividing by the duration between recorded measurements.

Four basic types of flow meters are described as follows:

#### Variable Area Flow Meters (rotameter)

Variable area flow meters, also known as rotameters, are used for both liquid and gaseous fuels. A rotameter consists of a tapered tube with an indicator inside that is pushed up by flow and pulled down by gravity. At a higher flow rate more area (between the indicator and the tube) is needed to accommodate the flow, so the indicator rises. The location of the indicator is visually compared with graduations on the tube to measure the flow rate of the fluid.

The accuracy of rotameters depends on the specific model, and is typically in the range of 2% to 5%.

#### Diaphragm Meters

Diaphragm meters, also known as dry test meters, are used for gaseous fuels. Diaphragm meters are positive-displacement devices that have fixed-volume measurement compartments formed by a two-sided convoluted diaphragm. A small pressure drop across the meter causes it to cycle. The compartments then alternately fill with gas at the inlet and empty at the outlet. By counting the number of cycles, the meter provides a measure of gas volume [2].

The accuracy of these flow indicators depends on the specific model, and is typically on the order of 1% [2].

#### Laminar Flow Elements

Laminar flow elements are typically used for gas flow measurements. In these types of meters, the volumetric flow rate is determined by creating a pressure drop across a unique internal restriction, known as a Laminar Flow Element (LFE), and measuring differential pressure across it. The restriction is designed so that the gas molecules are forced to move in parallel paths along the entire length of the passage; hence laminar (streamline) flow is established for the entire range of operation of the device. Unlike other flow measuring devices, in laminar flow meters the relationship between pressure drop and flow is linear [3].



ATF-LS-FRL-LI010 Calibration Burners	ID: 1566 Revision: 3
Authority: Technical Leader	Page: 3 of 8
Original maintained by Quality Programs; copies are uncontrolled.	

The accuracy of these flow indicators depends on the specific model, and is typically on the order of 0.5% to 1%. [3].

#### Ultrasonic Flow Meters

Ultrasonic flow meters are used for liquids and gases. These types of meters measure transit times of ultrasonic pulses passing through a fluid. Transmitters and receivers are located in multiple locations, enabling measurement of both upstream and downstream transit times. The difference in transit times of the downstream-directed pulses and the upstream-directed pulses is directly proportional to the velocity of the fluid being measured.

The accuracy of these flow indicators depend on the specific model, and are typically on the order of 1% [4].

#### Flow Controllers

Manual and automated flow controllers are used at the FRL. Manual flow controllers are often simple gate valves placed in line with the gas train or they can be pressure regulating devices. Automated flow controllers consist of a remote controlled flow controller whose position is regulated based upon feedback from the flow rate measurement. Automated flow controllers can be integral to flow measurement device as in the case of mass flow controllers, or they can be separate devices that are controlled by a computer program that adjusts the flow controller based upon readings from the flow meter.

The accuracy of these controllers depends on the specific model, and is typically on the order of 0.5% to 1%. [3].

#### Burners

Burners are designed in a wide variety of shapes and sizes depending on the intended purpose. Burners consist of a minimum of a connection to a fuel supply and a means for distributing the fuel. The following provides a brief description of the three primary types of burners used at FRL.

#### Sand Burners

Sand burners are used for gaseous fuels. Sand burners are constructed from open top noncombustible containers filled with an aggregate such as sand, gravel, or ceramic chips. A gas supply is located within the aggregate in a location such that the gas flux at the open surface is uniform. See technical reference TR010A for further information regarding sand burners.

#### Tube Burners

Tube burners are used for gaseous fuels. They are constructed from metal tubing with a fuel supply attached to one end and one or more holes at the locations where flame is desired. See technical reference TR010B for further information regarding tube burners.



### Atomizing Spray Burners

Atomizing spray burners are used for liquid fuels. The function of the spray burner is to transform the liquid into a flammable mist composed of small droplets of flammable liquid that will burn efficiently. Each spray burner is typically rated for a narrow range of flow rates. Therefore, the number of burners used in a test will depend upon the desired fire size.

## FireTOSS Calculations

### **HEAT RELEASE RATE CALCULATION**

The heat release rate (HRR) of the fire is calculated using the flow rate of the fuel and the combustion properties of the fuel. Equation (1.1) expresses the HRR in terms of the mass flow rate of the fuel.

$$\dot{Q} = \eta \cdot \dot{m} \cdot \Delta H_{C,net} \quad (0.1)$$

Equation (1.2) expresses the HRR in terms of the volumetric flow rate of the fuel.

$$\dot{Q} = \eta \cdot \rho \cdot \dot{V} \cdot \Delta H_{C,net} \quad (0.2)$$

where

- $Q$  = heat release rate of the burner (kW)
- $\eta$  = combustion efficiency of the fuel (assumed to be 1 for gaseous fuels).
- $\dot{m}$  = mass flow rate of the fuel (kg/s)
- $\Delta H_{C,net}$  = net heat of combustion of the fuel (kJ/kg)
- $\rho$  = density of the fuel (kg/m<sup>3</sup>)
- $\dot{V}$  = volumetric flow rate of the fuel (m<sup>3</sup>/s)



ATF-LS-FRL-LI010 Calibration Burners	ID: 1566 Revision: 3
Authority: Technical Leader	Page: 5 of 8
Original maintained by Quality Programs; copies are uncontrolled.	

## Uncertainty and Accuracy

The heat release rate uncertainty is a combination of the uncertainty of its components, including flow, density and heat of combustion, among other factors, and is given by the following equation [5 - 7]:

$$u_c(\dot{Q}) = \sqrt{\sum s_i^2 u(x_i)^2} \quad (0.3)$$

where:

- $u_c(\dot{Q})$  = Combined standard uncertainty of the burner heat release rate
- $u(x_i)$  = Standard uncertainty of each heat release rate component
- $s_i$  = Sensitivity coefficient ( $\partial y / \partial x_i$ )

Applying Eq. 1.3 to Eq. 1.2 yields:

$$u_c(\dot{Q}) = \left[ \begin{aligned} &(\eta \rho_{NG} \Delta H_{c,net})^2 (u(\dot{V}_{NG}))^2 + (\eta \dot{V} \Delta H_{c,net})^2 (u(\rho_{NG}))^2 \\ &+ (\eta \rho_{NG} \dot{V})^2 (u(\Delta H_{c,net}))^2 + (\rho_{NG} \dot{V} \Delta H_{c,net})^2 (u(\eta))^2 \end{aligned} \right]^{1/2} \quad (0.4)$$

where:

- $u(\eta)$  = Standard uncertainty of Combustion Efficiency
- $u(\dot{V}_{NG})$  = Standard uncertainty of Natural Gas Volumetric Flow Rate
- $u(\rho_{NG})$  = Standard uncertainty of Natural Gas Density
- $u(\Delta H_{c,net})$  = Standard uncertainty of Natural Gas Heat of Combustion

The heat release rate uncertainty calculated using Equation 1.4 is specific to a given burner configuration. The uncertainty in the fuel's net heat of combustion is dependent on the fuel type and the fuel source. The burning efficiency of the fuel is dependent on many factors including the burner configuration, the fuel type, and the fuel flow rate. To calculate a burner's burning efficiency an analysis must be done using as inputs the carbon monoxide and soot generation rates and a measure of the unburned hydrocarbons. The uncertainty of the flow rate measurement is dependent on the measuring instrument and is often not a constant but instead a function of several factors including the flow rate.



ATF-LS-FRL-LI010 Calibration Burners	ID: 1566 Revision: 3
Authority: Technical Leader	Page: 6 of 8
Original maintained by Quality Programs; copies are uncontrolled.	

## Operating Instructions

### **REQUIREMENTS**

1. The assigned operator shall be qualified in accordance with laboratory proficiency requirements.
2. Fuel flow rate instrument shall be calibrated and the calibration status shall be marked in accordance with FRL calibration procedures.
3. If data acquisition is used, the data acquisition equipment shall be calibrated and be marked with the calibration status in accordance with FRL calibration procedures.
4. If pressure transducers are used in the heat release rate calculation, the transducers shall be calibrated and be marked with the calibration status in accordance with FRL calibration procedures.
5. The fuel flow rate instrument shall be selected to represent the test conditions.

### **PROCEDURE**

The following is the general procedure that shall be followed for all burners regardless of type.

#### **1. Set up**

- 1.1 The calibration marking on the fuel flow measurement instrument shall be checked to confirm that the instrument is calibrated.
- 1.2 If data acquisition is used, the fuel flow measurement instrumentation shall be connected to the data acquisition hardware using the smallest input range that will bound the output range of the instrument.
- 1.3 Connect the flow controller to the fuel supply and outlet (i.e. burner, nozzle, etc.)
- 1.4 Verify that there are no leaks in the fuel supply lines.
- 1.5 Ensure that adequate fuel is available.

#### **2. Pre-Test**

- 2.1 The functionality of the fuel igniter (pilot) shall be confirmed.

#### **3. Test**

- 3.1 The burner ignition status shall be monitored and a person shall be in a position to shut off the fuel flow if the burner does not ignite or if the burner is extinguished during the test.
- 3.2 The fuel flow rate shall be monitored.

#### **4. Post Test**

- 4.1 Shut off valves from the fuel supply shall be closed.



ATF-LS-FRL-LI010 Calibration Burners	ID: 1566 Revision: 3
Authority: Technical Leader	Page: 7 of 8
Original maintained by Quality Programs; copies are uncontrolled.	

## Burner Documentation Requirements

When using a calibration burner during an experiment, there are two instruments in FireTOSS that must be used: a Gas Train and a Burner. Selecting one instrument automatically selects the other. Each instrument has its own input parameters, which are listed below in Table 1 and Table 2.

**Table 1 – Gas Train Data Acquisition Input Parameters**

Parameter	Required	Input Method
Status - Calibration	TRUE	Automatically Updated
Description	TRUE	User Input from List
Heat release rate E factor description	TRUE	User Input from List
Time out of service (s)	FALSE	User Input
Out of service reason	FALSE	User Input
Baseline time	FALSE	Automatically Updated
Fuel Heat of Combustion	TRUE	Automatically Updated
Fuel Density	TRUE	Automatically Updated
Mezzanine Pressure Baseline value	FALSE	Automatically Updated
Mezzanine Temp Baseline value	FALSE	Automatically Updated
NG Specific Gravity Baseline value	FALSE	Automatically Updated
Mezzanine Pressure data (Pa)	FALSE	Automatically Updated
NG Pipe Pressure data (Pa)	FALSE	Automatically Updated
Mezzanine Temperature Data (C)	FALSE	Automatically Updated
NG Temperature Data (C)	FALSE	Automatically Updated
Specific Gravity Data	FALSE	Automatically Updated
Pipe Fuel Density Data (kg/m <sup>3</sup> )	FALSE	Automatically Updated
Average Pipe Fuel Density	FALSE	Automatically Updated
Volumetric Flow Rate Data (m <sup>3</sup> /s)	FALSE	Automatically Updated
Heat Release Rate Data (kW)	FALSE	Automatically Updated
Cumulative Heat Release (kJ)	FALSE	Automatically Updated
MFC Bar Code	TRUE	Automatically Updated
MFC Serial number	TRUE	Automatically Updated
WS Bar Code	TRUE	Automatically Updated
WS Serial number	TRUE	Automatically Updated
CC Bar Code	TRUE	Automatically Updated
CC Serial number	TRUE	Automatically Updated
PT Bar Code	FALSE	Automatically Updated
PT Serial Number	FALSE	Automatically Updated

**Table 2 – Burner Data Acquisition Input Parameters**

Parameter	Required	Input Method
Burner Type	TRUE	User Input from List
Burner Dimensions	TRUE	Automatically Updated



ATF-LS-FRL-LI010 Calibration Burners	ID: 1566 Revision: 3
Authority: Technical Leader	Page: 8 of 8
Original maintained by Quality Programs; copies are uncontrolled.	

## References

1. ATF FRL Instruction, "Laboratory Instruction LI018: Combustion Calorimeter."
2. American Meter Company, [http://www.elster-americanmeter.com/en/diaphragm\\_meters.html](http://www.elster-americanmeter.com/en/diaphragm_meters.html)
3. "16 Series Mass and Volumetric Flow Controllers, Operating Manual," Alicat Scientific, Tucson, Arizona.
4. "Field Manual: System 1010N NEMA 4X Clamp-On Multi-Function Flowmeter," Controlotron Corp., 2003.
5. Taylor, B. N., & Kuyatt, C. E., "NIST Technical Note 1297: Guidelines for Evaluating and Expressing the Uncertainty of NIST Measurement Results," National Institute of Standards and Technology, Gaithersburg, MD 1993.
6. Bryant, A.R., Ohlemiller, T.J., Johnsson, E.L, Hamins, A., Grove, B.S., Guthrie, W.F., Maranghides, A., Mulholland, G.W., "Special Publication 1007," National Institute of Standards and Technology, 2003.
7. Guthrie, W. & Liu, H., "Hands-on Workshop on Estimating and Reporting Measurement Uncertainty," National Institute of Standards and Technology, Presentation given to CPSC, 2007.



ATF-LS-FRL-LI011 Fire Products Collectors	ID: 2668 Revision: 4
Authority: Technical Leader	Page: 1 of 23
Original maintained by Quality Programs; copies are uncontrolled.	

## Scope

This Laboratory Instruction covers the use of the large-scale Fire Products Collectors (FPCs) used in experiments conducted at the Bureau of Alcohol, Tobacco, Firearms and Explosives (ATF) Fire Research Laboratory (FRL).

## Instrument Description

### **GENERAL**

A large-scale FPC collects smoke and other products of combustion generated during fire experiments. Generally, a FPC consists of a collection hood connected to an exhaust duct, with air drawn through the duct by one or more variable speed fans. A FPC serves two purposes:

- 1) To remove combustion products from a laboratory space, and
- 2) To optimize the flow field for measurement and quantitative analyses of the combustion products.

### **INSTRUMENTATION**

The FPCs in the ATF FRL are equipped with instrumentation to measure gas species concentrations, velocity, and smoke concentration. Additional instruments, not located in the FPCs exhaust ducts, are used to measure the mass of the burning item and the ambient conditions in the laboratory.

#### Gas Species Concentration Measurement

Gas species concentrations are measured by extracting a continuous sample from the exhaust duct, conditioning the sample by removing particulates and moisture, and delivering the sample at the required pressure and flow rate to a set of gas analyzers. Sample extraction is performed using a gas sampling probe located in the FPC exhaust duct; the sample conditioning equipment and gas analyzers are located in a remote instrument rack.

#### Gas Sampling Probe

The gas sampling probe is used to draw samples from across the full diameter of the exhaust duct. For large diameter ducts two probes, positioned at 90° spacing, may be used. The sampling probe is positioned downstream of an orifice where the gases and other product species are well mixed. The probe consists of a stainless steel tube with 2–4 mm diameter sampling holes positioned at regular intervals across the length of the duct. The sampling probe(s) is installed with the sampling holes facing downstream. The gas sample is drawn from both ends of the probe(s) and transported to the gas analysis rack through a single gas sampling line. Details on the layout of the gas sampling probes are provided in the Technical Reference for each FPC.

#### Gas Analysis Rack

The gas analysis rack contains instrumentation to draw a continuous sample from the duct, condition the sample, and measure the concentrations of oxygen (O<sub>2</sub>), carbon dioxide (CO<sub>2</sub>) and carbon monoxide (CO) in the gas sample. The gas sample is pre-treated prior to reaching the



ATF-LS-FRL-LI011 Fire Products Collectors	ID: 2668 Revision: 4
Authority: Technical Leader	Page: 2 of 23
Original maintained by Quality Programs; copies are uncontrolled.	

analyzers to remove particulate materials and moisture that can damage the analyzers. This pre-treatment is accomplished through a series of particulate filters and sample driers (including cold traps, desiccant columns and / or membrane dryers). The concentrations of O<sub>2</sub>, CO<sub>2</sub>, and CO are measured by the gas analyzer [1, 2].

### Velocity Measurement

Gas velocity measurements in the FPCs are performed with differential pressure probes [3] because of their ruggedness and simplicity. Differential pressure probes are based on the Bernoulli Principle, which relates velocity to the difference between the total and static pressure in a flow field [4]. Velocity is calculated based on measured differential pressure and the temperature of the gases at the probe location. The ATF FRL uses both bi-directional probes [5] and averaging pressure probes [6].

#### *Bi-Directional Probe*

A bi-directional probe is used to make point velocity measurements in the exhaust duct [5]. The probe is positioned at a fixed radial location in the duct with the axis of the probe in line with the flow direction. Due to the fact that the velocity profile is generally not flat across the duct cross section, a correction factor is applied to determine the average velocity based on the value measured at a single location. The average velocity is then used to calculate both the volumetric flow rate and the mass flow rate of the gases in the exhaust duct.

#### *Averaging Pressure Probe*

Averaging pressure probes are designed to span the cross section of a pipe or duct [6]. This type of probe is characterized by multiple pressure taps spaced at precise intervals in order to deliver a measurement that represents the average differential pressure for flow in a duct. The advantage of this type of probe is that the average velocity, and hence the flow rate, can be calculated without requiring knowledge of the velocity profile.

#### *Differential Pressure Transducers*

Differential pressure transducers are used to measure the differential pressure between the high and low pressure sides of the velocity probes. The pressure measurement is corrected for the zero pressure differential offset, which is measured by cross porting the high and low pressure ports and measuring the transducer output.

#### *Thermocouple*

In addition to differential pressure, temperature measurements are required to calculate velocity. The FPCs use Inconel-sheathed, K-type thermocouples to measure temperature at the differential pressure probe locations [7].

### Smoke Measurement

Smoke is measured in the FPCs using optical density meters (ODMs) [8, 9]. An ODM uses an optical technique in which a beam of light is passed across the exhaust duct and attenuated by smoke particles in the flow field. The smoke concentration is calculated based on the reduced



ATF-LS-FRL-LI011 Fire Products Collectors	ID: 2668 Revision: 4
Authority: Technical Leader	Page: 3 of 23
Original maintained by Quality Programs; copies are uncontrolled.	

light intensity across the fixed path. Smoke is measured with both laser and white-light ODMs in the FPCs. The ODM access port is located downstream of the velocity and gas sampling probes. The laser ODMs for the FPCs use low-power Helium-Neon (HeNe) lasers that emit continuous light at 632 nm. The white-light ODMs for the FPCs use broad-band visible (white) light source.

### Mass Measurement

Additional quantitative data, such as the effective heat of combustion, the species yields (CO and CO<sub>2</sub>), and smoke yield, can be obtained from a FPC by measuring the mass of an object as it burns. A range of weighing devices may be used with a FPC depending on the mass of the object and the desired measurement sensitivity [10].

### Ambient Conditions Measurement

Ambient conditions within the laboratory space are monitored so that the moisture content of the ambient air can be calculated. The mole fraction of water in the ambient air is an input used for the calculation of heat release rate (HRR). Weather stations located throughout the ATF FRL monitor and record ambient conditions of temperature, barometric pressure and relative humidity [11].

## **REPORTED QUANTITIES**

Fire Products Collectors are designed to provide four primary quantities: heat release rate (HRR), convective heat release rate (CHRR), gas species production and smoke production. When used in conjunction with a weighing device, such as a load cell, the mass loss rate (MLR) of the burning object can be calculated. Gas species yields, smoke yield, and the effective heat of combustion of a burning item can then be calculated based on the MLR.

### Heat Release Rate

The heat release rate (HRR) is a measure of the amount of heat evolved from an item per unit of time. HRR measurements are based on the principle of oxygen consumption calorimetry [12]. The principle is based on the fact that the chemical energy released in a fire, per unit mass of oxygen consumed for complete combustion, is relatively constant for many organic fuels [13, 14]. The ATF FRL calculates HRR based on the oxygen consumption principle using measurements of oxygen, carbon monoxide, and carbon dioxide [12].

### Convective Heat Release Rate

The convective heat release rate (CHRR) of a fire is the rate at which energy is transferred to the gases that flow through the FPC. The CHRR is an important parameter in correlations for fire plumes and sprinkler / detector activation. It can also be used to determine the radiative fraction of a fire. The CHRR is calculated as the enthalpy rise of gases flowing through the FPC and is based on the temperature and velocity measurements in the exhaust duct.



ATF-LS-FRL-LI011 Fire Products Collectors	ID: 2668 Revision: 4
Authority: Technical Leader	Page: 4 of 23
Original maintained by Quality Programs; copies are uncontrolled.	

### Mass Loss Rate

The mass loss rate (MLR) is a measure of the decrease in mass of an object as it burns. The MLR is used in conjunction with other measurements to calculate gas species yields, smoke yield, and the effective heat of combustion of a burning item.

### Gas Species Production

The gas species released during a fire can be expressed in various ways, including total mass production (kg), mass production rate (kg/s), or in terms of a yield (kg/kg specimen burned). These metrics are calculated based on the measured concentrations of the combustion gas species and the mass flow rate in the FPC exhaust stream. The yield for a particular combustion gas is the ratio of the mass of the gas species produced to the mass lost by the burning object [12]. The total mass of combustion gas released, and the rate of gas release, are important parameters for fire hazard analyses. Gas species yields are important parameters for fire modeling applications.

### Smoke Production

Similar to gas species production, smoke production can be expressed in various ways, including the total smoke released (TSR, m<sup>2</sup>), rate of smoke release (RSR, m<sup>2</sup>/s), or in terms of a yield (kg/kg specimen burned). RSR is calculated as the product of the light extinction coefficient,  $k$  (m<sup>-1</sup>), and the FPC volumetric flow rate,  $\dot{V}$  (m<sup>3</sup>/s). TSR is an integration of the RSR over the test duration. RSR and TSR are used to compare the smoke production from burning items and determine the associated fire hazard. Smoke yield is the ratio of the mass of smoke produced to the mass lost by the burning object. Smoke yield is an important parameter for fire modeling applications. Optical density per meter ( $D$ , m<sup>-1</sup>) is proportional to the extinction coefficient.

### Effective Heat Of Combustion

The effective heat of combustion is the amount of heat generated by an object per unit mass lost during a fire [15]. It is calculated by dividing the HRR calculated by the FPC by the mass loss rate (MLR) of the burning object.

### **CALIBRATION**

Calculation of HRR relies on the use of a calibration factor, or C Factor [16]. The C Factor is determined by placing a calibration burner [17] beneath the FPC and controlling the fuel flow to the burner through a series of well-characterized steps. The type of calibration burner is selected based on the desired maximum HRR needed for the calibration. The C Factor is defined as the ratio of the burner HRR to the calculated HRR based on the FPC measurements.



## FireTOSS Calculations

### HEAT RELEASE RATE

The HRR is calculated using the oxygen consumption principle based on the measurement of oxygen, CO and CO<sub>2</sub> concentrations, in addition to velocity [12]:

$$HRR = C \left[ E\phi - (E_{CO} - E) \frac{1 - \phi}{2} \frac{X_{CO}}{X_{O_2}} \right] \left( \frac{\dot{m}}{1 + \phi(\alpha - 1)} \right) \left( \frac{MW_{O_2}}{MW_{air}} \right) (1 - X_{H_2O}^0) X_{O_2}^0 \quad (1)$$

where

$C$  = FPC calibration factor or “C Factor”

$HRR$  = measured heat release rate (kW)

$\phi$  = oxygen depletion factor; a measure of the amount of oxygen that has been removed from the ambient air by the combustion process; Eq. (2)

$E$  = net heat release per unit of O<sub>2</sub> consumed (a property of the fuel being burned); Values of  $E$  for various fuels are provided in Table 1; Appendix A explains how these values were determined.

$E_{CO}$  = net heat release per unit of mass of O<sub>2</sub> consumed for combustion of CO to CO<sub>2</sub>,  $E_{CO} = 17,600$  kJ/kg [12]

$\dot{m}$  = mass flow rate through the exhaust duct (kg/s); Eq. (5)

$\alpha$  = gas volumetric expansion factor (a property of the fuel being burned); Values of  $\alpha$  for various fuels are provided in Table 1; Appendix A explains how these values were determined.

$MW_{O_2}$  = molecular weight of oxygen;  $MW_{O_2} = 32.00$  kg/kmol [12]

$MW_{air}$  = molecular weight of air; Eq. (8)

$X_{O_2}$  = measured mole fraction of oxygen

$X_{CO}$  = measured mole fraction of carbon monoxide

$X_{O_2}^0$  = ambient mole fraction of oxygen

$X_{H_2O}^0$  = ambient mole fraction of water; Eq. (6)



ATF-LS-FRL-LI011 Fire Products Collectors	ID: 2668 Revision: 4
Authority: Technical Leader	Page: 6 of 23
Original maintained by Quality Programs; copies are uncontrolled.	

**Table 1. Properties of Fuel Gases**

Fuel	E (kJ/g O <sub>2</sub> )	α (—)
Default	13.10	1.105
Methane	12.54	1.105
Propane	12.77	1.040
Natural Gas	12.55	1.084

The oxygen depletion factor ( $\phi$ ) is calculated as:

$$\phi = \frac{X_{O_2}^0 (1 - X_{CO_2} - X_{CO}) - X_{O_2} (1 - X_{CO_2}^0)}{X_{O_2}^0 (1 - X_{O_2} - X_{CO_2} - X_{CO})} \quad (2)$$

where

$X_{CO_2}$  = measured mole fraction of CO<sub>2</sub>

$X_{CO_2}^0$  = ambient mole fraction of CO<sub>2</sub>

### Mass Flow Rate

The mass flow rate ( $\dot{m}$ ) in the exhaust duct is calculated based on the velocity of the gas through the duct [3]. The velocity of the exhaust gases is used to determine the volumetric flow of the gases ( $\dot{V}$ ) from

$$\dot{V} = k_f v A \quad (3)$$

where

$k_f$  = empirical velocity profile shape factor that relates the average velocity across the exhaust duct to the measured velocity; see the Technical Reference for each FPC for the appropriate value.

$A$  = area of the exhaust duct (m<sup>2</sup>)

$v$  = measured velocity in the exhaust duct (m/s)

The exhaust mass flow rate ( $\dot{m}$ ) is calculated as



$$\dot{m} = \dot{V} \rho \quad (4)$$

Using the Ideal Gas Law, assuming dry air at 1 atm, the mass flow rate equation becomes

$$\dot{m} = \dot{V} \frac{353.05}{T} \quad (5)$$

### Water Vapor

The ambient mole fraction of water in ambient air ( $X_{H_2O}^0$ ) is calculated from [12]:

$$X_{H_2O}^0 = \frac{RH P_s(T_0)}{100 P_0} \quad (6)$$

where

$RH$  = relative humidity (%)

$P_s$  = saturation pressure of water at  $T_0$  (Pa); Eq. (7)

$T_0$  = ambient temperature (K)

$P_0$  = atmospheric pressure (Pa)

The saturation pressure of water as a function of the ambient temperature is calculated from:

$$\ln(P_s) = 23.2 - \frac{3816}{(-46 + T_0)} \quad \text{-or-} \quad P_s = e^{23.2 - \frac{3816}{(-46 + T_0)}} \quad (7)$$

The molecular weight of air is corrected for the moisture content according to:

$$MW_{air} = MW_{air,dry}(1 - X_{H_2O}^0) + MW_{H_2O}X_{H_2O}^0 \quad (8)$$

where

$MW_{air}$  = molecular weight of air; used in Eq. 1

$MW_{air,dry}$  = molecular weight of dry air (29 g mol<sup>-1</sup>) [12]

$MW_{H_2O}$  = molecular weight of water (18 g mol<sup>-1</sup>) [12]

$X_{H_2O}^0$  = ambient mole fraction of water; calculated from Eq. (6)

### **CONVECTIVE HEAT RELEASE RATE**

The CHRR of a fire is the rate at which energy is transferred to the gases that flow through a control volume surrounding the fire. This can be expressed mathematically by the First Law of Thermodynamics for a control volume. For a system with a single inlet and exit under steady



ATF-LS-FRL-LI011 Fire Products Collectors	ID: 2668 Revision: 4
Authority: Technical Leader	Page: 8 of 23
Original maintained by Quality Programs; copies are uncontrolled.	

state conditions, with no work and negligible changes in kinetic and potential energy, the CHRR can be expressed as [18]:

$$\dot{Q}_c = \dot{m}(h_2 - h_1) \quad (9)$$

where

- $\dot{Q}_c$  = convective heat release rate (kW)
- $\dot{m}$  = mass flow rate in the exhaust duct (kg/s); Eq. (5)
- $h_2$  = enthalpy at the exit of the control volume; Eq. (11)
- $h_1$  = enthalpy at the inlet of the control volume; Eq. (11)

The enthalpy of air is calculated from the measured temperature using a polynomial expression [19, 20]:

$$h(T) = \left( \alpha T + \beta \frac{T^2}{2} + \gamma \frac{T^3}{3} + \delta \frac{T^4}{4} + \varepsilon \frac{T^5}{5} \right) \quad (10)$$

where

- $h(T)$  = enthalpy of air (kJ/kg)
- $T$  = air temperature (K)
- $a$  = 1.0595
- $b$  = -4.8068E-4
- $g$  = 1.234E-6
- $d$  = -8.9161E-10
- $e$  = 2.1957E-13

The inlet enthalpy,  $h_1$ , is characterized by the average temperature measured prior to the start of the test. It is assumed that this is the condition of the air entering the control volume throughout the duration of experiment. The exit enthalpy,  $h_2$ , is computed using the FPC exhaust temperature measurement.

### **MASS LOSS RATE**

When a weighing device is used, the mass loss rate (MLR) of a burning object can be calculated as an average value for the entire test duration (or a portion thereof), or as a time-varying value. The average MLR for the test duration is computed as follows:

$$\dot{m}_{f,avg} = \frac{m_n - m_0}{t_d} \quad (11)$$

where



ATF-LS-FRL-LI011 Fire Products Collectors	ID: 2668 Revision: 4
Authority: Technical Leader	Page: 9 of 23
Original maintained by Quality Programs; copies are uncontrolled.	

- $\dot{m}_{f,avg}$  = average mass loss rate of burning object (kg/s)
- $m_n$  = final mass of burning object (kg)
- $m_0$  = initial mass of burning object (kg)
- $t_d$  = test duration (s)

Anomalies at the beginning or end of a test may cause the average mass loss rate for the test duration to be skewed. For example, if a test is allowed to continue for an extended time after mass loss of the burning object has ceased, the average mass loss rate calculated in Eq. (11) will be artificially low. To address this potential issue, an average mass loss rate is also computed during the period when 10 percent to 90 percent of the total mass loss has occurred. ASTM E1354 uses this approach to report the mass loss rate from small-scale oxygen consumption calorimeter experiments [21]. The average mass loss rate of a burning object during the period when 10 percent to 90 percent of the total mass loss occurred is calculated as follows:

$$\dot{m}_{f,avg,1090} = \frac{m_{10} - m_{90}}{t_{90} - t_{10}} \quad (12)$$

where

- $\dot{m}_{f,avg,1090}$  = average mass loss rate of burning object during the period when 10 percent to 90 percent of the total mass loss occurred (kg/s)
- $m_{10}$  = mass of burning object when 10 percent of total mass loss occurred (kg)
- $m_{90}$  = mass of burning object when 90 percent of total mass loss occurred (kg)
- $t_{10}$  = time at which 10 percent of total mass loss occurred (s)
- $t_{90}$  = time at which 90 percent of total mass loss occurred (s)

The time varying mass loss rate is calculated using a least-squares linear regression through the given point and a total of  $n$  surrounding points:

$$\dot{m}_f(t) = -\frac{(\sum t * \sum m) - (n * \sum m * t)}{(\sum t * \sum t) - (n * \sum t * t)} \quad (13)$$

where

- $\dot{m}_f(i)$  = mass loss rate of burning object at time  $t$  (kg/s)
- $m$  = mass of burning object (kg)
- $t$  = time (s)
- $n$  = number of data points used in the linear regression calculation



## **GAS SPECIES PRODUCTION**

The gas species mass production rate is calculated as [16 ,22]:

$$\dot{m}_x = \dot{m}(X - X_0) \left( \frac{M_x}{M_a} \right) \quad (14)$$

where

$\dot{m}_x$  = mass production rate of species  $x$  (kg/s)

$\dot{m}$  = mass flow rate through the exhaust duct (kg/s); Eq. (5)

$X$  = species mole fraction during an experiment

$X_0$  = species mole fraction pre-test baseline value.

$M_x$  = molecular weight of species  $x$  (kg/kmol)

$M_a$  = molecular weight of air (29 kg/kmol)

The total mass produced is calculated by integrating the mass production rate over the test duration:

$$m_x = \int \dot{m}_x dt$$

where

$m_x$  = total mass of species  $x$  produced (kg)

The gas yield can be calculated as an average value for the entire test duration, or as a time-varying value. The average gas yield is computed as follows:

$$f_{x,avg} = \frac{m_x}{m_0 - m_n} \quad (15)$$

where

$f_{x,avg}$  = average gas yield for species  $x$  (kg/kg)

$m_n$  = final mass of burning object (kg)

$m_0$  = initial mass of burning object (kg)

The time-varying gas yield ( $f_x(t)$ ) is calculated as the ratio of the gas species mass production rate and the time-varying MLR of the burning object:



ATF-LS-FRL-LI011 Fire Products Collectors	ID: 2668 Revision: 4
Authority: Technical Leader	Page: 11 of 23
Original maintained by Quality Programs; copies are uncontrolled.	

$$f_x(t) = \frac{\dot{m}_x(t)}{\dot{m}_f(t)} \quad (16)$$

where

- $f_x(t)$  = gas yield of species  $x$  at time  $t$  (kJ/kg)
- $\dot{m}_x(t)$  = mass production rate of species  $x$  at time  $t$  (kg/s);
- $\dot{m}_f(t)$  = mass loss rate of burning item at time  $t$  (kg/s); Eq. (13)

### SMOKE PRODUCTION

Smoke production is quantified based on optical smoke measurements, which measure the attenuation of light as it passes through a particulate and gaseous medium. Light absorption by gas molecules is characterized by an absorption coefficient; light scattering by particulates is characterized by a scattering coefficient. These combine to produce an extinction coefficient,  $k_\lambda$ . The extinction coefficient is a proportionality coefficient that relates the differential change in light intensity as it passes through a medium [23]:

$$dI_\lambda = -k_\lambda I_\lambda dL \quad (17)$$

where

- $I_\lambda$  = spectral light intensity
- $k_\lambda$  = extinction coefficient ( $m^{-1}$ )
- $L$  = path length that the light passes through a medium (m)

Equation (17) can be rearranged and integrated to produce:

$$\ln \frac{I_{\lambda,L}}{I_{\lambda,0}} = -\int_0^L k_\lambda dL \quad (18)$$

In a uniform medium, in which  $k_\lambda$  does not vary along the path, Eq. (18) simplifies to:

$$k_\lambda = \frac{1}{L} \ln \frac{I_{\lambda,0}}{I_{\lambda,L}} \quad (19)$$

In this expression  $I_{\lambda,0}$  is the intensity of the light at its source, and  $I_{\lambda,L}$  is the intensity of the light reaching a detector at the end of the path. Equation (19) applies strictly to monochromatic (laser) light, however it is often generalized for use with broadband light sources, such as white light, by removing the spectral dependence. Additionally, a correction factor,  $f$ , is applied to account for nonlinearities in the measurement system:



ATF-LS-FRL-LI011 Fire Products Collectors	ID: 2668 Revision: 4
Authority: Technical Leader	Page: 12 of 23
Original maintained by Quality Programs; copies are uncontrolled.	

$$k = f \frac{1}{L} \ln \frac{I_0}{I_L} \quad (20)$$

The correction factor  $f$  is calculated from the measured intensity  $I_L$  through a filter with known optical density [24]. The optical density per meter,  $D$ , (sometimes referred to as simply the optical density) is calculated as follows:

$$D = f \frac{1}{L} \log_{10} \frac{I_0}{I_L} \quad (21)$$

The optical density per meter is related to the extinction coefficient according to  $D = k/2.3$ .

Equation (20) is used to calculate the extinction coefficient for both laser and white light measurements. The rate of smoke release (RSR,  $m^2/s$ ) is then calculated as the product of the extinction coefficient and the air volumetric flow rate [16, 22]:

$$RSR = k\dot{V} \quad (22)$$

By integrating Eq. (21) over the entire test duration, the total smoke released (TSR) is obtained [16, 22]:

$$TSR = \int RSR \, dt \quad (23)$$

The average smoke yield ( $f_{s,avg}$ ) is used to quantify smoke production in terms of a mass ratio, similar to the gas species yields, when mass loss of the burning object is known [25]:

$$f_{s,avg} = \frac{m_s}{m_f} = \frac{\frac{1}{\sigma_s} TSR}{m_0 - m_n} \quad (24)$$

where the integral is taken over the entire test duration, and

$\sigma_s$  = specific extinction coefficient,  $8.7E3 \, m^2/kg$  [26]

$m_n$  = final mass of burning object (kg)

$m_0$  = initial mass of burning object (kg).

The time-varying smoke yield is calculated as follows:

$$f_s(t) = \frac{\frac{1}{\sigma_s} RSR}{\dot{m}_f(t)} \quad (25)$$



ATF-LS-FRL-LI011 Fire Products Collectors	ID: 2668 Revision: 4
Authority: Technical Leader	Page: 13 of 23
Original maintained by Quality Programs; copies are uncontrolled.	

where

$\dot{m}_f(t)$  = mass loss rate of burning item at time  $t$  (kg/s); Eq. (13).

### **EFFECTIVE HEAT OF COMBUSTION**

The effective heat of combustion is expressed by the following general relationship between the HRR and the MLR of a burning item [15]:

$$\Delta h_c = \frac{HRR}{MLR} \quad (26)$$

where

$\Delta h_c$  = effective heat of combustion (kJ/kg)

$HRR$  = measured heat release rate (kW)

$MLR$  = mass loss rate (kg/s)

The effective heat of combustion can be computed as an average value for the entire test duration, or as a time-varying value. The average effective heat of combustion is computed as follows:

$$\Delta h_{c,avg} = \frac{\int HRR dt}{m_0 - m_n} \quad (27)$$

where the integral is taken over the entire test duration, and

$\Delta h_{c,avg}$  = average effective heat of combustion for the test (kJ/kg)

$HRR$  = measured heat release rate (kW)

$m_n$  = final mass of burning object (kg)

$m_0$  = initial mass of burning object (kg)

The time-varying effective heat of combustion is computed as follows:

$$\Delta h_c(t) = \frac{HRR(t)}{\dot{m}_f(t)} \quad (28)$$

where

$\Delta h_c(t)$  = effective heat of combustion at time  $t$  (kJ/kg)

$HRR(t)$  = measured heat release rate at time  $t$  (kW); Eq. (1)



ATF-LS-FRL-LI011 Fire Products Collectors	ID: 2668 Revision: 4
Authority: Technical Leader	Page: 14 of 23
Original maintained by Quality Programs; copies are uncontrolled.	

$\dot{m}_f(t)$  = mass loss rate of burning item at time  $t$  (kg/s); Eq. (13)

### **CALIBRATION FACTOR**

The calibration factor, or C Factor, is determined by calculating the average HRR of the calibration burner and the FPC during each step. The HRR of the calibration burner is calculated according to its Laboratory Instruction [17] and the HRR of the FPC is calculated according to Equation (1).

A least squares linear regression analysis is performed on the average heat release rates of the burner and FPC. The burner data is plotted with respect to the measured FPC data; the C Factor is the slope of the linear regression line. Appendix B contains an example C Factor determination.

### **Uncertainty and Accuracy**

The uncertainty of the FPCs was estimated using the guidelines of the National Institute of Standards and Technology (NIST) Special Publication 1007 [27], NIST Technical Note 1297 [28], and the NIST Uncertainty Workshop [29]. The combined standard uncertainty of a FPC is a combination of the uncertainty of its components given by the following equation:

$$u_c = \sqrt{\sum s_i^2 u(x_i)^2} \quad (29)$$

where:

- $u_c$  = Combined standard uncertainty
- $u(x_i)$  = Standard uncertainty of each component
- $s_i$  = Sensitivity coefficient ( $\partial/\partial x_i$ )

Uncertainty is specific to the instrumentation used in each FPC, and is therefore documented in the Technical Reference for the FPC.

### **Operating Instructions**

A FPC is a system of instruments, and the requirements and procedures for the individual instruments apply to the FPC [1, 3, 7, 8, 10, 11, 17]. These requirements and procedures will not be repeated in this Laboratory Instruction.

### **REQUIREMENTS**

1. The assigned operator shall be qualified in accordance with laboratory proficiency requirements.
2. All FPC instruments used in the experiment shall be calibrated or functionally verified and marked with the calibration/verification status in accordance with FRL procedures.
3. The laboratory condition station selected for the experiment shall be in close proximity to the FPC.



ATF-LS-FRL-LI011 Fire Products Collectors	ID: 2668 Revision: 4
Authority: Technical Leader	Page: 15 of 23
Original maintained by Quality Programs; copies are uncontrolled.	

4. The FPC shall be selected based on the anticipated fire size and the desired accuracy of the measurement.
5. A HRR calibration experiment shall be conducted prior to each series of FPC experiments, and within 30 days of any test within the series.

## **PROCEDURE**

### **1. Setup**

- a. The calibration/functional verification marking on all FPC instruments used in the experiment shall be checked to confirm that the instrument is calibrated / verified.
- b. All FPC instruments shall be connected to the data acquisition hardware utilizing the smallest voltage input range that will bound the output range of the instrument.

### **2. Calibration**

- a. A calibration experiment shall include at least three (3) heat release rate steps.
- b. The first HRR step shall be 0 kW.
- c. The maximum HRR step shall be selected based on the anticipated fire size.
- d. The calibration factor (C Factor) shall be between the values of 0.95 and 1.05.
- e. The calibration factor (C Factor) shall not vary by more than  $\pm 5$  percent from the previous calibration.
- f. If the CFactor does not meet the requirements in (d) or (e), the system shall be checked for problems. Once the problems have been corrected, a new calibration experiment shall be conducted.

### **3. Prior to Each Test**

- a. Perform functional verification of any FPC instrument for which it is required.

### **4. During the Test**

- a. The output of each FPC instrument used in the experiment shall be recorded for the duration of the experiment.
- b. Exception – When any FPC instrument must be removed prior to the end of the experiment due to experiment design or impending damage, the elapsed time at which the instrument was removed and the reason for removal shall be recorded.

### **5. Post Test**

- a. If an instrument was taken out of service during an experiment, the out of service time and reason shall be recorded. Calculations shall be repeated with the updated out of service time.
- b. If conditions occurred during or following the experiment that could potentially affect the performance of a FPC instrument, a functional verification of that instrument shall be performed.



ATF-LS-FRL-LI011 Fire Products Collectors	ID: 2668 Revision: 4
Authority: Technical Leader	Page: 16 of 23
Original maintained by Quality Programs; copies are uncontrolled.	

## Documentation Requirements

Use of the FPCs shall be documented using the FireTOSS experiment design program. The information that the user shall document about the FPC is shown in Table 2. The first column in Table 2 shows the description of input parameter that will appear in the column heading of the FireTOSS experiment design program. The second column in Table 2 shows whether the parameter is required in all cases, and column three describes the method by which the field for each parameter is filled.

**Table 2: FPC Data Acquisition Input Parameters**

Parameter	Required	Input Method
Description	TRUE	User Input from List
Fuel Type	TRUE	User Input from List
HRR Calc	FALSE	User Input from Checkbox
CHRR Calc	FALSE	User Input from Checkbox
CFACTOR Calc	FALSE	User Input from Checkbox
Gas Calc	FALSE	User Input from Checkbox
SMOKE Calc	FALSE	User Input from Checkbox
YIELDS Calc	FALSE	User Input from Checkbox
Baseline Experiment	FALSE	User Input
C Factor Experiment ID	FALSE	User Input
Heat release rate - C Factor	TRUE	User Input
Calorimeter-Time out of service time	FALSE	User Input
Calorimeter- Out of service reason	FALSE	User Input
Expansion factor	TRUE	Automatically Updated
E factor	TRUE	Automatically Updated
Time baseline	FALSE	Automatically Updated
Duct diameter	TRUE	Automatically Updated
Flow shape factor	TRUE	Automatically Updated
Velocity Probe Diameter	TRUE	Automatically Updated
Velocity Probe Description	TRUE	Automatically Updated
Pressure Transducer 1 Bar Code	TRUE	Automatically Updated
Pressure Transducer 1 Serial Number	TRUE	Automatically Updated
Pressure Transducer 2 Bar Code	FALSE	Automatically Updated
Pressure Transducer 2 Serial Number	FALSE	Automatically Updated
Gas Analyzer Bar Code	TRUE	Automatically Updated
Gas Analyzer Serial number	TRUE	Automatically Updated
Delay Time Oxygen	TRUE	Automatically Updated
Delay Time CO/CO2	TRUE	Automatically Updated
Baseline Value Pressure Transducer 2	FALSE	User Input
Smoothing algorithm	FALSE	Automatically Updated



ATF-LS-FRL-LI011 Fire Products Collectors	ID: 2668 Revision: 4
Authority: Technical Leader	Page: 17 of 23
Original maintained by Quality Programs; copies are uncontrolled.	

Parameter	Required	Input Method
Smoothing algorithm parameter 1	FALSE	Automatically Updated
Baseline Value Pressure Transducer 1	FALSE	User Input
Delay Time Temperature	FALSE	Automatically Updated
Smoke - Main detector Span	FALSE	User Input
Smoke- Main Detector Zero	FALSE	User Input
Smoke - Comp Detector Span	FALSE	User Input
Smoke- Comp Detector Zero	FALSE	User Input
Smoke- White Detector Zero	FALSE	User Input
Smoke- White Detector Span	FALSE	User Input
Smoke- Laser OD Filter	FALSE	User Input
Smoke- White OD Filter	FALSE	User Input
Smoke- Main Laser Detector Filter Signal	FALSE	User Input
Smoke- White Detector Filter Signal	FALSE	User Input
Smoke- Laser Pathlength	FALSE	Automatically Updated
Smoke- White Pathlength	FALSE	Automatically Updated
Smoke- Delay Time	FALSE	Automatically Updated
Procedure for Out of Range Values Max	FALSE	User Input from List
Procedure for Out of Range Values Min	FALSE	User Input from List



ATF-LS-FRL-LI011 Fire Products Collectors	ID: 2668 Revision: 4
Authority: Technical Leader	Page: 18 of 23
Original maintained by Quality Programs; copies are uncontrolled.	

## List of Standards

The following table lists the applicable standards for the FPC.

**Table 3. List of Standards**

<b>Standard</b>	<b>Description</b>	<b>Ref</b>
NFPA 289	Standard Method of Fire Test for Individual Fuel Packages	16
ASTM E2067	Standard Practice for Full-Scale Oxygen Consumption Calorimetry Fire Tests	22



ATF-LS-FRL-LI011 Fire Products Collectors	ID: 2668 Revision: 4
Authority: Technical Leader	Page: 19 of 23
Original maintained by Quality Programs; copies are uncontrolled.	

## References

1. ATF FRL Laboratory Instruction, Point Source Gas Analysis, ATF-LS-FRL-LI016.
2. ATF FRL Technical Reference, Servomex 4100 Gas Purity Analyzers, ATF-LS-FRL-TR016a.
3. ATF FRL Laboratory Instruction, Velocity – Differential Pressure, ATF-LS-FRL-LI009.
4. Fox, R. W., and McDonald, A. T., *Introduction to Fluid Mechanics*, 3<sup>rd</sup> Edition, Wiley, 1985.
5. ATF FRL Technical Reference, Differential Pressure – Point Velocity Probes, ATF-LS-FRL-TR009a.
6. ATF FRL Technical Reference, Differential Pressure – Averaging Velocity Probes, ATF-LS-FRL-TR009b.
7. ATF FRL Laboratory Instruction, Thermocouple, ATF-LS-FRL-LI001.
8. ATF FRL Laboratory Instruction, Optical Density Meter, ATF-LS-FRL-LI014.
9. ATF FRL Technical Reference, Optical Density Meter Fire Products Collector, ATF-LS-FRL-TR014a.
10. ATF FRL Laboratory Instruction, Weighing Devices, ATF-LS-FRL-LI019.
11. ATF FRL Laboratory Instruction, Laboratory Condition, ATF-LS-FRL-LI017.
12. Babrauskas, V., Grayson, S. ed., *Heat Release in Fires*, E & FN Spon, London, 1992.
13. Thorton, W., “The Relation of Oxygen to the Heat of Combustion of Organic Compound,” *Philosophical Magazine and Journal Of Science*, Vol. 33, No. 196, 1917.
14. Huggett, C., Estimation of the Rate of Heat Release by Means of Oxygen Consumption, *Journal of Fire and Flammability*, Vol. 12, 1980.
15. Babrauskas, V., “Heat Release Rate,” *SFPE Handbook of Fire Protection Engineering*, 4<sup>th</sup> Ed., National Fire Protection Association, Quincy, Massachusetts, p 3-1, 2008.
16. NFPA 289, *Standard Method of Fire Test for Individual Fuel Packages*, 2023 Ed., National Fire Protection Association, Quincy, Massachusetts, 2013.
17. ATF FRL Laboratory Instruction, Calibration Burners, ATF-LS-FRL-LI010.
18. Janssens, M., “Calorimetry”, *SFPE Handbook of Fire Protection Engineering*, 3<sup>rd</sup> Ed., National Fire Protection Association, Quincy, Massachusetts, p 3-54, 2002.
19. “Tables of Thermal Properties of Gases”, NBS Circular 564, 1955.
20. Kyle, B. G., “Chemical and Process Thermodynamics”, Englewood Cliffs / Prentice Hall, 1984.



ATF-LS-FRL-LI011 Fire Products Collectors	ID: 2668 Revision: 4
Authority: Technical Leader	Page: 20 of 23
Original maintained by Quality Programs; copies are uncontrolled.	

21. ASTM E1354-23, *Standard Test Method for Heat and Visible Smoke Release Rates for Materials and Products Using an Oxygen Consumption Calorimeter*, ASTM International, West Conshohocken, Pennsylvania, 2023.
22. ASTM E2067-23, *Standard Practice for Full-Scale Oxygen Consumption Calorimetry Fire Tests*, ASTM International, West Conshohocken, Pennsylvania, 2023.
23. Incropera, F. P., and DeWitt, D. P., *Fundamentals of Heat and Mass Transfer, 3<sup>rd</sup> Ed.*, Wiley and Sons, New York, 1990.
24. User's Guide for the Laser Smoke Measurement Unit – For Use with Large Scale Heat Release Systems, Fire Testing Technology, Issue 2.1, 2001.
25. Putorti, Jr., A.D., “Design Parameters for Stack-Mounted Light Extinction Measurement Devices,” NISTIR 6215, National Institute of Standards and Technology, Gaithersburg, Maryland, July 1999.
26. Mulholland, G.W., and Croarkin, C., “Specific Extinction Coefficient of Flame Generated Smoke,” *Fire and Materials*, Vol. 24, 2000.
27. Bryant, A.R., Ohlemiller, T.J., Johnsson, E.L, Hamins, A., Grove, B.S., Guthrie, W.F., Maranghides, A., Mulholland, G.W., “Special Publication 1007,” National Institute of Standards and Technology, Gaithersburg, Maryland, 2003.
28. Taylor, B. N., & Kuyatt, C. E., “NIST Technical Note 1297: Guidelines for Evaluating and Expressing the Uncertainty of NIST Measurement Results,” National Institute of Standards and Technology, Gaithersburg, Maryland, 1993.
29. Guthrie, W. & Liu, H., “Hands-on Workshop on Estimating and Reporting Measurement Uncertainty,” National Institute of Standards and Technology, Gaithersburg, Maryland, Presentation given to the Consumer Product Safety Commission (CPSC), 2007.



## Appendix A – Fuel Property Determination

### ***VOLUMETRIC EXPANSION FACTOR ( $\alpha$ )***

The volumetric expansion factor accounts for the expansion of the incoming air molecules into combustion products based on a complete combustion reaction (all carbon is converted to carbon dioxide). To calculate the volumetric expansion factor, the ratio is taken between the total moles of combustion products and the total moles of air (oxygen and nitrogen). One mole of air is 21% oxygen and 79% nitrogen. Trace amounts of argon and other gases are neglected. This relates to 3.76 moles of nitrogen for every one mole of oxygen. Although nitrogen is inert and does not take part in the combustion reaction the volume of the nitrogen must be conserved through the reaction. An example of a volumetric expansion factor calculation is provided below.

In the following chemical equation for the combustion of propane ( $C_3H_8$ ), 5 moles of oxygen are needed to completely oxidize one mole of propane. The volume of air required to contain five moles of oxygen will also contain 18.8 moles of nitrogen, which will be conserved through the reaction. The volume of air will contain a total of 23.8 moles, which expands to 25.8 moles of combustion products. This results in a volumetric expansion factor of  $\alpha = 25.8 / 23.8$  or  $\alpha = 1.084$ .

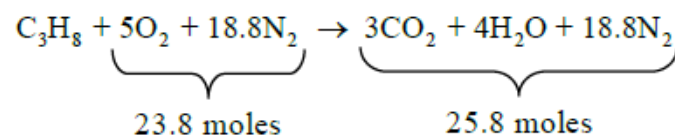

### ***NET HEAT RELEASED PER UNIT MASS OF OXYGEN CONSUMED (E)***

The basis of oxygen consumption heat release measurements is founded on the net heat released per unit mass of oxygen consumed during the combustion process. If the chemical formula of the fuel being burned is known, the value for E can be determined based on the chemical reaction, the molecular weight of the fuel and the net heat of combustion of the fuel ( $\Delta H_{C, net}$ ).

For the combustion reaction described, the net heat of combustion of propane is 46.34 kJ/g and the molecular weight is 44.094 g/mol. Therefore, for each mole of propane burned, 2,043.3 kJ of heat are released. Since this one mole of propane reacts with 5 moles of oxygen (total mass of 160 g), the net heat released per unit mass of oxygen is  $E = 204.3 \text{ kJ}/160 \text{ g}$  or  $E = 12.77 \text{ kJ}/\text{g } O_2$ . When the chemical reaction is unknown, a default value of 13.1 kJ/g  $O_2$  can be used and is accurate to within  $\pm 5 \%$  for most fuels [13, 14].



ATF-LS-FRL-LI011 Fire Products Collectors	ID: 2668 Revision: 4
Authority: Technical Leader	Page: 22 of 23
Original maintained by Quality Programs; copies are uncontrolled.	

## Appendix B – Calibration Factor Determination

This Appendix contains informative, non-mandatory information on how the calibration factor, or C Factor, is determined for a Fire Products Collector (FPC). Figure 1 shows an example of a calibration burner experiment using nine (9) heat release steps ranging from 0 to 1100 kW. The average heat release rate output of the gas burner and the average heat release rate measured by the FPC are determined at each step. The averages are calculated during the steady-state period of each step.

Once the average heat release rate is calculated for the burner and the FPC at each step, the data is plotted as shown in Figure 2. A least squares linear regression analysis is performed with the y-intercept forced through zero. The C Factor is the slope of the least squares linear regression line. When the measured heat release rate data is corrected with the calculated C-Factor, the data from Figure 1 is transformed into the data in Figure 3.

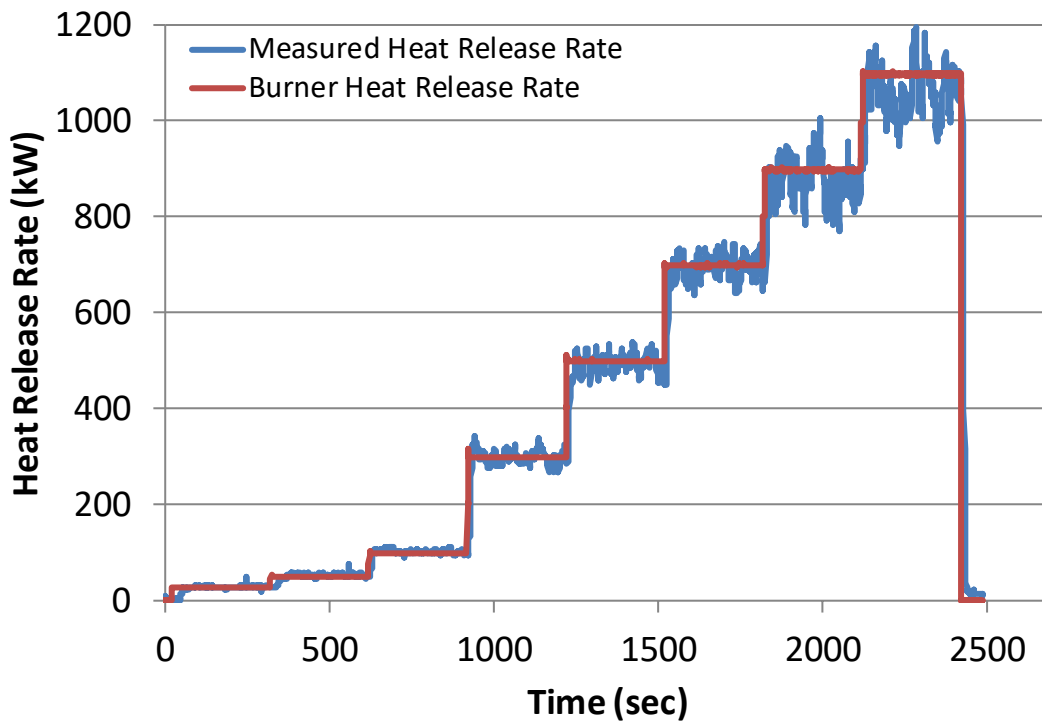

Figure 1. Example of a Nine-Point Burner Calibration Experiment



ATF-LS-FRL-LI011 Fire Products Collectors	ID: 2668 Revision: 4
Authority: Technical Leader	Page: 23 of 23
Original maintained by Quality Programs; copies are uncontrolled.	

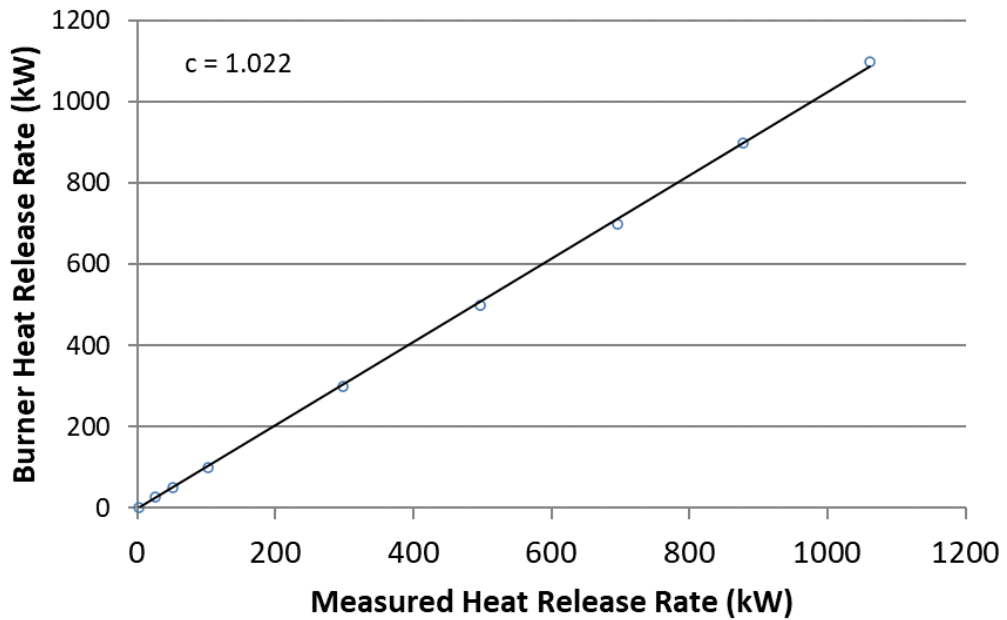

Figure 2. Example of a Nine-Point Burner C-Factor Determination

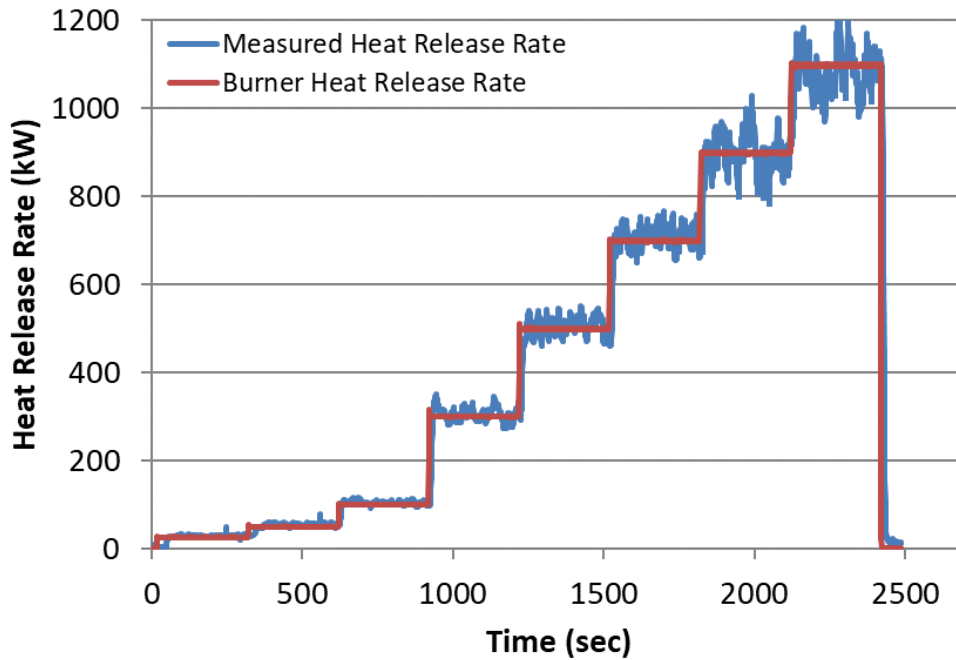

Figure 3. Measured Heat Release Rate Corrected with C-Factor



ATF-LS-FRL-LI014 - Optical Density Meter	ID: 2675 Revision: 3
Authority: Technical Leader	Page: 1 of 6
Original maintained by Quality Programs; copies are uncontrolled.	

## Scope

This Laboratory Instruction covers the use, design and specifications of optical density meters (ODMs) for smoke measurement in the Bureau of Alcohol, Tobacco, Firearms and Explosives (ATF) Fire Research Laboratory (FRL).

## Instrument Description

### **GENERAL**

Smoke measurements in fires are performed for a variety of reasons including toxicity assessment, visibility calculation, and model validation. Measurements are inherently difficult to perform in high temperature environments due to instrument limitations; however smoke data can be obtained downstream of a fire where reduced temperatures allow for use of sensitive instruments. The ATF FRL uses optical density meters to perform smoke measurements; these allow for good time resolution, they can be performed non-intrusively, and are not as labor intensive relative to other smoke measurement techniques.

### **OPERATING PRINCIPLE**

Fires generate a range of products including gaseous species, aerosols and particulates. Optical smoke measurements are based on the attenuation of light as it passes through a particulate and gaseous medium. Light attenuation can be measured using a two part instrument comprised of a light source and a photo-detecting transducer. The photo-detecting transducer is designed such that it responds when subjected to the intensity of the light source. The transducer produces an output that is linear with the amount of light it receives. When a light source and transducer are arranged across a fixed path length, quantitative information can be inferred from the measured output.

### **METER APPLICATION**

The operating principle for all optical density meters is generally the same, however the instrumentation used and the calculations performed depend on the application. The FRL uses ODMs for two primary applications: custom experiments and fixed location.

#### Custom Experiments

In custom experiments the instrument placement is scenario dependent. Often times ODMs are used in experiments involving a compartment or structure; the ODM can be placed in an area removed from the fire that is not expected to have high temperature exposure. This application provides a local smoke measurement where multiple ODMs can be used in a single experiment [1].

#### Fixed Location

Fixed location refers to applications where the ODM is mounted to a duct and measurements are performed on the sample passing through the duct. The FRL Fire Product Collectors and Cone Calorimeter are equipped with ODMs mounted to the duct several diameters downstream of the collection hood [2]. This application provides an integrated measurement of the smoke produced by the experiment.



## THEORY

Light absorption by gas molecules is characterized by an absorption coefficient; light scattering by particulates is characterized by a scattering coefficient. These combine to produce a spectral extinction coefficient,  $k_\lambda$ , that represents the total attenuation of light by a given medium. The extinction coefficient can be viewed as a proportionality coefficient in the expression that relates the differential change in light intensity as it passes through a differential medium [3]:

$$dI_\lambda = -k_\lambda I_\lambda dL \quad (1.1)$$

In this expression,  $I_\lambda$  is the spectral light intensity and  $L$  is the path length that the light passes through a medium. Equation 1.1 can be rearranged and integrated to produce:

$$\ln \frac{I_{\lambda,L}}{I_{\lambda,0}} = -\int_0^L k_\lambda dL \quad (1.2)$$

In a uniform medium, in which  $k_\lambda$  does not vary along the path, Equation 1.2 simplifies to:

$$k_\lambda = \frac{1}{L} \ln \frac{I_{\lambda,0}}{I_{\lambda,L}} \quad (1.3)$$

In this expression  $I_{\lambda,0}$  is the intensity of the light at its source, and  $I_{\lambda,L}$  is the intensity of the light reaching a detector at the end of the path. Equation 1.3 applies strictly to monochromatic (laser) light, however it is often generalized for use with broadband light sources, such as white light, by removing the spectral dependence ( $\lambda$ ). Additionally, a correction factor,  $f$ , is sometimes applied to account for nonlinearities in the measurement system:

$$k = f \frac{1}{L} \ln \frac{I_0}{I_L} \quad (1.4)$$

The correction factor  $f$  is calculated from the measured intensity  $I_L$  through a filter with known optical density [4]. The optical density per meter,  $D$ , (sometimes referred to as simply the optical density) is calculated as follows [5]:

$$D = f \frac{1}{L} \log_{10} \frac{I_0}{I_L} \quad (1.5)$$

The optical density per meter is related to the extinction coefficient according to  $D = k/2.3$ .



ATF-LS-FRL-LI014 - Optical Density Meter	ID: 2675 Revision: 3
Authority: Technical Leader	Page: 3 of 6
Original maintained by Quality Programs; copies are uncontrolled.	

## FireTOSS Calculations

### ***FIRE PRODUCT COLLECTOR***

The relation generalized in Equation 1.4 is used to calculate the extinction coefficient for both laser and white light measurements. The rate of smoke release (RSR) is then calculated as the product of the extinction coefficient and the product volumetric flow rate in the duct:

$$RSR = k\dot{V} \quad (1.6)$$

A third quantity that is of interest is the total smoke released (TSR). This is obtained by integrating the RSR rate over time [4].

### ***CUSTOM EXPERIMENTS***

Percent obscuration,  $O$ , is used in visibility calculations and is calculated as follows [6]:

$$O = 100\% \left[ 1 - \frac{I_L}{I_0} \right] \quad (1.7)$$

Percent obscuration per unit length is used in detector design and is compared against manufactures' specifications for the detectors. Percent obscuration per meter is calculated according to [6]:

$$O_{u,meters} = 100\% \left[ 1 - \left( \frac{I}{I_0} \right)^{\frac{1}{L_{meters}}} \right] \quad (1.8)$$

## Uncertainty and Accuracy

The uncertainty of the ODMs was estimated using the guidelines of the National Institute of Standards and Technology (NIST) Special Publication 1007 [7], NIST Technical Note 1297 [8], and the NIST Uncertainty Workshop [9]. The combined standard uncertainty of a ODM is a combination of the uncertainty of its components given by the following equation:

$$u_c = \sqrt{\sum s_i^2 u(x_i)^2} \quad (29)$$

where:

- $u_c$  = Combined standard uncertainty
- $u(x_i)$  = Standard uncertainty of each component
- $s_i$  = Sensitivity coefficient ( $\partial/\partial x_i$ )



ATF-LS-FRL-LI014 - Optical Density Meter	ID: 2675 Revision: 3
Authority: Technical Leader	Page: 4 of 6
Original maintained by Quality Programs; copies are uncontrolled.	

The FRL utilizes ODMs which have different light sources and photo detecting transducers. The uncertainty of each ODM varies depending on the instruments used and the path length measurement. Uncertainty calculations discussed in the appropriate Technical Reference.

## Operating Instructions

### **REQUIREMENTS**

1. The assigned operator shall be qualified in accordance with laboratory proficiency requirements.
2. The data acquisition instrumentation shall be calibrated and be marked with the calibration status in accordance with FRL calibration procedures.
3. Optical density meters shall be functionally verified in accordance with FRL procedures.

### **TEST PROCEDURE**

#### **1. Setup**

- 1.1. All ODM instruments shall be connected to the data acquisition hardware utilizing the smallest input range that will bound the output range of the instrument.

#### **2. Prior to the First Test in a Series**

- 2.1. Operation of the ODM shall be verified using the appropriate functional verification procedure.

#### **3. Prior to Each Test**

- 3.1. The output of the ODM shall be verified to be stable.

#### **4. During the Test**

- 4.1. The output of the ODM shall be recorded for the duration of the experiment.
- 4.2. Exception – When the ODM must be taken out of service prior to the end of an experiment due to experiment design or impending damage, the elapsed time at which the instrument was removed and the reason for instrument removal shall be recorded.

#### **5. Post Test**

- 5.1. If an instrument was taken out of service during an experiment, the out of service time and reason shall be recorded. Calculations shall be repeated with the updated out of service time.
- 5.2. If conditions occurred during or following the experiment that could potentially affect the performance of an ODM, a functional verification of that instrument shall be performed prior to its use in future experiments.

## Optical Density Meter Documentation Requirements

Optical density meter usage during experiments shall be documented using the FireTOSS experiment design program. The information that the user can document about the optical density meter is shown in Table 1 and Table 2, depending on the type of ODM used. The first column shows the description of input parameter that will appear in the column heading of the FireTOSS experiment design program. The second column shows whether the parameter is required in all cases, and column three describes the method by which the field for each parameter is filled.



ATF-LS-FRL-LI014 - Optical Density Meter	ID: 2675 Revision: 3
Authority: Technical Leader	Page: 5 of 6
Original maintained by Quality Programs; copies are uncontrolled.	

**Table 1.** Data Acquisition Input Parameters for Custom Experiment White Light ODM

Parameter	Required	Input Method
Description	TRUE	User Input
Bar Code	TRUE	User Input
X	FALSE	User Input
Y	FALSE	User Input
Z	FALSE	User Input
Light Source Type	FALSE	User Input from List
Extinction Beam Path Length	TRUE	User Input
C Factor	TRUE	User Input
Smoke Main Detector Zero	FALSE	User Input
Time Out of Service	FALSE	User Input
Out of Service Reason	FALSE	User Input
Chart Number	FALSE	User Input
Procedure for Out of Range Values Max	FALSE	User Input from List
Procedure for Out of Range Values Min	FALSE	User Input from List
Maximum Allowable measurement	FALSE	User Input
Minimum Allowable Measurement	FALSE	User Input

**Table 2.** Data Acquisition Input Parameters for Fire Product Collector ODM

Parameter	Required	Input Method
Smoke - Main detector Span	FALSE	User Input
Smoke- Main Detector Zero	FALSE	User Input
Smoke - Comp Detector Span	FALSE	User Input
Smoke- Comp Detector Zero	FALSE	User Input
Smoke- White Detector Zero	FALSE	User Input
Smoke- White Detector Span	FALSE	User Input
Smoke- Laser OD Filter	FALSE	User Input
Smoke- White OD Filter	FALSE	User Input
Smoke- Main Laser Detector Filter Signal	FALSE	User Input
Smoke- White Detector Filter Signal	FALSE	User Input
Smoke- Laser Pathlength	FALSE	Automatically Updated
Smoke- White Pathlength	FALSE	Automatically Updated
Smoke- Delay Time	FALSE	Automatically Updated
Smoke – Laser time out of service	FALSE	User Input
Smoke – Laser out of service reason	FALSE	User Input
Smoke – White light time out of service	FALSE	User Input
Smoke – White light out of service reason	FALSE	User Input



ATF-LS-FRL-LI014 - Optical Density Meter	ID: 2675 Revision: 3
Authority: Technical Leader	Page: 6 of 6
Original maintained by Quality Programs; copies are uncontrolled.	

## References

1. ATF FRL Technical Reference, Optical Density Meter Custom Experiments, ATF-LS-FRL-TR014b.
2. ATF FRL Technical Reference, Optical Density Meter Fire Products Collector, ATF-LS-FRL-TR014a.
3. Incropera, F. P., and DeWitt, D. P., *Fundamentals of Heat and Mass Transfer, 3<sup>rd</sup> Ed.*, Wiley and Sons, New York, 1990.
4. User's Guide for the Laser Smoke Measurement Unit – For Use with Large Scale Heat Release Systems, Fire Testing Technology, Issue 2.1, 2001.
5. Mulholland, G. W., “Smoke Production and Properties,” *SFPE Handbook of Fire Protection Engineering, 3<sup>rd</sup> Ed.*, National Fire Protection Association, Quincy, Massachusetts, p 2-263, 2002.
6. Schifiliti, R. P., Meacham, B. J., and Custer, R. L. P., “Design of Detection Systems,” *SFPE Handbook of Fire Protection Engineering, 3<sup>rd</sup> Ed.*, National Fire Protection Association, Quincy, Massachusetts, p 4-22, 2002.
7. Bryant, A.R., Ohlemiller, T.J., Johnsson, E.L, Hamins, A., Grove, B.S., Guthrie, W.F., Maranghides, A., Mulholland, G.W., “Special Publication 1007,” National Institute of Standards and Technology, Gaithersburg, MD, 2003.
8. Taylor, B. N., & Kuyatt, C. E., “NIST Technical Note 1297: Guidelines for Evaluating and Expressing the Uncertainty of NIST Measurement Results,” National Institute of Standards and Technology, Gaithersburg, MD, 1993.
9. Guthrie, W. & Liu, H., “Hands-on Workshop on Estimating and Reporting Measurement Uncertainty,” National Institute of Standards and Technology, Presentation given to CPSC, 2007.



ATF-LS-FRL-LI015 Velocity-Hot Wire Anemometers	ID: 1594 Revision: 4
Authority: Technical Leader	Page: 1 of 6
Original maintained by Quality Programs; copies are uncontrolled.	

## Scope

This instruction covers the use, design, and specifications of Hot Wire Anemometers (HWA) used at the Bureau of Alcohol, Tobacco, Firearms and Explosives (ATF) Fire Research Laboratory (FRL).

## Instrument Description

### GENERAL

Hot wire anemometers are used for a wide range of applications for both internal and external velocity measurements. HWA are commonly used to measure velocity inside of ducts or pipes to calculate volumetric or mass flow rate. HWA are also used for point velocity measurements of external flows and have better sensitivity to low speed flows than differential pressure probes. These characteristics make HWA well suited for use in convective flows associated with fires, however they are typically restricted to low temperature environments.

A HWA consists of one or more resistive thermal device (RTD) elements that each constitute one active leg of a Wheatstone bridge circuit. The RTD sensors are electrically heated wire elements which are controlled by one of two types of solid- state electronics: constant temperature or constant power. Constant- temperature anemometers are more prevalent because they have a quick response time and low electronic noise, are compatible with liquids and gases, and are immune from sensor burnout when there is a sudden drop in flow. The FRL uses HWA that operate in constant-temperature mode.

HWA use the principles of convective heat transfer to determine fluid velocity. In a constant-temperature anemometer the RTD sensor is heated to maintain a constant temperature above that of the surrounding fluid. As a fluid flows past, the sensor is cooled convectively. The amount of power required to maintain the constant temperature is measured and converted to an electrical signal proportional to the fluid velocity.

The electrical output varies depending on the model of HWA. Some models produce a DC voltage signal, while others produce a current output. A current output can be converted to a voltage by using a resistor in parallel with the signal. For example, a 250 Ohm resistor can be used to convert a 4 – 20 mA output to a 1 – 5 V signal based Ohm's Law:

$$V = R * I \quad (1.1)$$

where:

V = Voltage

R = Resistance

I = Current



ATF-LS-FRL-LI015 Velocity-Hot Wire Anemometers	ID: 1594 Revision: 4
Authority: Technical Leader	Page: 2 of 6
Original maintained by Quality Programs; copies are uncontrolled.	

## Uncertainty and Accuracy

The uncertainty and accuracy of HWA's are dependent on the manufacturer, model, operating temperature, range, and output type. The uncertainty analysis provided here is based on two models from the same manufacturer [1, 2]. The analysis is approached differently for each model because of the output types. Both are constant temperature anemometers, however one produces a current output and the other produces a voltage output. The current output model has an additional component, the resistor, which has an effect on the overall uncertainty of the velocity measurement. In both cases, it is reasonable to assume that the errors, stated by manufacturer literature, have a rectangular probability distribution, in which case the standard uncertainty of each component is computed by Equation 1.2 [3].

$$u(x) = \frac{e}{\sqrt{3}} \quad (1.2)$$

where:

$u(x)$  = Standard uncertainty  
 $e$  = Error/accuracy of the measurement

When more than one source of uncertainty is present for a measurement, the values can be combined in quadrature to achieve a combined standard uncertainty, using Equation 1.3 [3-5]:

$$u_c(X) = \sqrt{\sum s_i^2 u(x_i)^2} \quad (1.3)$$

where:

$u_c(X)$  = Combined standard uncertainty  
 $u(x_i)$  = Standard uncertainty component  
 $s_i^2$  = Sensitivity coefficient ( $\partial y / \partial x_i$ )

The specifications for each model are found in the User's Guides [1, 2].

For the current output model [1], the accuracy is listed as  $\pm 1.5\%$  of full scale at room temperature, plus  $\pm 0.5\%$  of reading from 0 to 50 °C (32 to 122 °F), plus 1% of full scale if the velocity measurement is below 5.1 meters per second (m/s) (1000 SFPM). For a 1 m/s (200 SFPM) anemometer operating under typical conditions in the FRL, the worst case accuracy (assuming full scale flow) is then  $\pm 3\%$ . The repeatability is listed as  $\pm 0.2\%$  of full scale.

Using Equation 1.2, the accuracy and repeatability at 1 m/s (200 SFPM) yield standard uncertainties of  $\pm 0.018$  m/s ( $\pm 3.46$  SFPM) and  $\pm 0.001$  m/s ( $\pm 0.23$  SFPM), respectively. These values combined in quadrature result in a combined standard uncertainty for the instrument of  $\pm 0.018$  m/s ( $\pm 3.47$  SFPM). In terms of raw current, the combined standard uncertainty correlates to  $\pm 0.2776$  mA.



ATF-LS-FRL-LI015 Velocity-Hot Wire Anemometers	ID: 1594 Revision: 4
Authority: Technical Leader	Page: 3 of 6
Original maintained by Quality Programs; copies are uncontrolled.	

An additional source of error is a resistor that converts the current output to a voltage. For a 250 Ohm resistor with an accuracy of  $\pm 0.1\%$  the standard uncertainty is  $\pm 0.144$  Ohms.

The total uncertainty in the final voltage signal can be calculated by applying Equation 1.3 to Equation 1.1 yielding Equation 1.4.

$$u_c(V) = \sqrt{(R)^2(u(I))^2 + (I)^2(u(R))^2} \quad (1.4)$$

$$u_c(V) = \sqrt{(250)^2(0.0002776)^2 + (0.02)^2(0.144)^2} = \pm 0.069 \text{ Volts}$$

This correlates to a combined standard uncertainty of  $\pm 0.018$  m/s (3.47 SFPM).

For the voltage output anemometers [2], the accuracy is listed as  $\pm 1.5\%$  of full scale which equates to  $\pm 0.08$  m/s ( $\pm 15$  SFPM) for HWA with a 5.1 m/s (1000 SFPM) range. Applying Equation 1.2, the standard uncertainty is  $\pm 0.044$  m/s ( $\pm 8.7$  SFPM).

## Operating Instructions

### REQUIREMENTS

1. The assigned operator shall be qualified in accordance with laboratory proficiency requirements.
2. The data acquisition equipment shall be calibrated and be marked with the calibration status in accordance with FRL calibration procedures.
3. Hot wire anemometers shall be calibrated and be marked with the calibration status in accordance with FRL calibration procedures.

### PROCEDURE

#### 1. Set up

- 1.1 The calibration marking on the HWA shall be checked to confirm that the instrument is calibrated.
- 1.2 HWA shall be connected to the data acquisition hardware using the smallest voltage input range that will bound the output range of the transducer.
- 1.3 HWA must be exposed to the environment for a period of at least five minutes prior to the start of the test.
- 1.4 Align sensor probe with the air flow. The air flow shall be perpendicular to the sensor window.
- 1.5 A type-K SLE thermocouple shall be installed near the HWA.



ATF-LS-FRL-LI015 Velocity-Hot Wire Anemometers	ID: 1594 Revision: 4
Authority: Technical Leader	Page: 4 of 6
Original maintained by Quality Programs; copies are uncontrolled.	

## 2. Pre-Test

- 2.1 The surfaces of the temperature and velocity sensor elements shall be inspected for soot and or debris. All soot and debris shall be removed according to manufacturer instructions.
- 2.2 The signal output of the HWA and thermocouple shall be verified using the DAQ.

## 3. Test

- 3.1 The output of the HWA shall be recorded for the duration of the experiment.
- 3.2 Exception I- When the HWA must be removed prior to the end of the experiment due to experiment design or impending damage to the instrument. The elapsed time at which the probe was removed and the reason for instrument removal shall be recorded.
- 3.3 Exception II- The gas temperature surrounding the HWA shall be measured. If the gas temperature exceeds the temperature limit as set by the HWA's manufacturer, the HWA shall be taken "Out of Service" for the duration of the experiment. The elapsed time at which the HWA was removed and the reason for the instrument removal shall be recorded.

## 4. Post Test

- 4.1 After the experiment, velocity probes in areas where they may have been damaged shall be examined for visible damage or surface dirt.
- 4.2 If damage or surface dirt is observed on the velocity/ temperature sensing probe, the instrument shall be taken out of service until it has been cleaned according to manufacturer's instructions.
- 4.3 If damage has occurred to the electronics casing, the instrument shall be taken out of service and sent in for recalibration.

## Hot wire Anemometer Documentation Requirements

HWA usage shall be documented using the FireTOSS experiment design program. The information that the user shall document about the HWA is shown in Table 1. The first column in Table 1 shows the description of input parameter that will appear in the column heading of the FireTOSS experiment design program. The second column in Table 1 shows whether the parameter is required in all cases, and column three provides a description of the information to be supplied for the parameter.

**Table 1: Data Acquisition Input Parameters**

Parameter	Required	Parameter Description
Conversion Factors	True	(m, b) Taken directly from the FRL calibration database.
Description	True	Description of the location of the HWA.
Type	True	Description of probe type.
Serial number	True	Manufacturer's serial number
Bar code	True	FRL Equipment identification number (asset number)
Over Range	True	The maximum temperature exposure range of the HWA



ATF-LS-FRL-LI015 Velocity-Hot Wire Anemometers	ID: 1594 Revision: 4
Authority: Technical Leader	Page: 5 of 6
Original maintained by Quality Programs; copies are uncontrolled.	

Parameter	Required	Parameter Description
Range	True	Input the maximum flow velocity
Manufacturer	True	Manufacturer of the HWA
Model	True	Manufacturer's model number
Chart	False	Allows the user to group instrument data onto different charts. If this parameter is left empty, data for similar instruments will be put on one chart.
Out of service time	False	Indicates the elapsed test time that the instrument was removed from the test. All calculations for the data on the instrument cease at this time.
Out of service reason	False	Specifies the reason that the instrument was removed from the experiment. Reasons typically include damage, impending damage, or test design



ATF-LS-FRL-LI015 Velocity-Hot Wire Anemometers	ID: 1594 Revision: 4
Authority: Technical Leader	Page: 6 of 6
Original maintained by Quality Programs; copies are uncontrolled.	

## References

1. “FPA-900 Series Air Velocity Transducers User’s Guide,” Omega Engineering Inc., Stamford, CT, 2005.
2. “FPA-1000 Series Air Velocity Transducers User’s Guide,” Omega Engineering Inc., Stamford, CT, 2010.
3. Guthrie, W. & Liu, H., “Hands-on Workshop on Estimating and Reporting Measurement Uncertainty,” National Institute of Standards and Technology, Presentation given to CPSC, 2007.
4. Taylor, B. N., & Kuyatt, C. E., “NIST Technical Note 1297: Guidelines for Evaluating and Expressing the Uncertainty of NIST Measurement Results,” National Institute of Standards and Technology, Gaithersburg, MD, 1993.
5. Bryant, A.R., Ohlemiller, T.J., Johnsson, E.L, Hamins, A., Grove, B.S., Guthrie, W.F., Maranghides, A., Mulholland, G.W., “Special Publication 1007,” National Institute of Standards and Technology, Gaithersburg, MD, 2003.



ATF-LS-FRL-LI016 Point Source Gas Analysis	ID: 1579 Revision: 4
Authority: Technical Leader	Page: 1 of 5
Original maintained by Quality Programs; copies are uncontrolled.	

## Scope

This instruction covers the use of gas concentration measurements using gas analyzers utilizing either a paramagnetic or infrared absorption principle. This laboratory instruction covers the use of gas analyzers as a standalone instrument or as part of a system with a collection of instruments such as the cone calorimeter or Fire Product Collectors (FPC).

## Instrument Description

### **GENERAL**

Gas analyzers determine the concentration of a gas species in a mixture of gases through the unique properties of that gas. For analyzers that utilize a paramagnetic principle, the response of the gas in a varying magnetic field is utilized to determine the presence and concentration of a paramagnetic species, like oxygen, in the mixture. For analyzers that utilize an infrared absorption principle, the absorption of infrared light over a wavelength range is utilized to determine the presence and concentration of species, like carbon dioxide or carbon monoxide, in a gas mixture.

Gas analyzers are utilized remotely from the measurement location with a continuous sample drawn from the measurement location and pumped through the analyzers via tubing. The sample is pre-treated prior to reaching the analyzers to remove particulate materials and moisture that can damage the analyzers. This pre-treatment is accomplished through a series of filters, cold traps and desiccant filters. To reduce the transit time between the sampling point and the analyzer, a by-pass flow is incorporated into the sampling apparatus.

Some types of gas analyzers require a reference gas to flow through the analyzer as well as the sample gas.

### **UNCERTAINTY AND ACCURACY**

The uncertainty and accuracy of the gas analyzer varies with make and model. Typical analyzer specifications consist of combined instrument accuracy, linearity of response and repeatability representing errors less than 3% of the full scale concentration range for which it is calibrated.

## Operating Instructions

### **REQUIREMENTS**

1. The assigned operator shall be qualified in accordance with laboratory proficiency requirements.
2. The data acquisition equipment shall be calibrated and be marked with the calibration status in accordance with FRL calibration procedures.



## PROCEDURE

### 1. Set-up

- a. Analyzer output signals shall be connected to the data acquisition hardware utilizing the smallest voltage input range that will bound the output range of the analyzer.
- b. Tubing through which the gas will flow to the analyzer will be of the appropriate size and construction for the environment and flows to be encountered.
- c. If deemed necessary, the exhaust flow from the analyzer will be returned to the test chamber.
- d. All required gasses will be connected to the analyzer. This may include but is not limited to a reference gas, a zero gas and a span calibration gas.
- e. Delay time in analyzer response will be measured and sample line checked for leaks.

### 2. Pre-Test

- a. Desiccant filter will be changed and particulate filters cleaned/replaced.
- b. Sample line blown down to remove any clogs.
- c. Reference gas flow initiated, if necessary.
- d. Analyzer turned on and allowed to warm up.
- e. Analyzer calibrated with both a zero and span.
- f. Sample gas flow initiated with flow rate set for the analyzer and by-pass flows.

### 3. Test

- a. The output of the analyzer shall be recorded for the duration of the experiment

### 4. Post-Test

- a. Analyzer shall be checked for any damage
- b. Flow rate to the analyzer shall be checked to determine whether sample lines became clogged during the test.
- c. Gas sample flow shall be secured

## Gas Analyzer Documentation Requirements

Gas analyzer usage shall be documented using the FireTOSS experiment design program. When using a gas analyzer, there are two instruments that need to be added to FireTOSS. For oxygen analysis, the "Oxygen Analyzer" instrument must be added. For carbon dioxide and carbon monoxide analysis, the "CO CO<sub>2</sub> Analyzer" instrument must be added. The FireTOSS input parameters for the Paramagnetic O<sub>2</sub> analyzer and NDIR CO CO<sub>2</sub> analyzers are shown in Table 1 and Table 2, respectively.



ATF-LS-FRL-LI016 Point Source Gas Analysis	ID: 1579 Revision: 4
Authority: Technical Leader	Page: 3 of 5
Original maintained by Quality Programs; copies are uncontrolled.	

**Table 1 – “Paramagnetic O<sub>2</sub>” Data Acquisition Parameters**

Parameter	Parameter Description	Required	Input Method
Calibration Status	Determines if the instrument was in calibration for the experiment.	True	Automatic
Bar Code	The FRL provided bar code for the instrument.	True	User
Serial number	The manufacturer provided serial number.	True	Automatic
Description	Description of the location of the sample probe.	True	User
Location X	In conjunction with a diagram of the experiment set up, this parameter is used to identify the X location in meters of the sample probe	False	User
Location Y	In conjunction with a diagram of the experiment set up, this parameter is used to identify the Y location in meters of the sample probe	False	User
Location Z	In conjunction with a diagram of the experiment set up, this parameter is used to identify the height in meters, of the sample probe	False	User
Manufacturer	Manufacturer	False	Automatic
Model number	The manufacturer provided model number	False	Automatic
Status-Gas Sample Exhaust Return Line	Description of where the exhaust line vents: To Ambient Laboratory or To Test Chamber.	True	User Selectable
Time out of service time	Indicates the elapsed test time that the instrument was removed from the test. All calculations for the data on the instrument cease at this time.	False	User
Out of service reason	Specifies the reason that the instrument was removed from the experiment. Reasons typically include damage, impending damage, or test design	False	User
O <sub>2</sub> Analyzer Full Scale Range	Full scale range that measurements were made on; default value = 0.25	True	User
O <sub>2</sub> Analyzer Span Value	Span gas concentration, usually taken as the oxygen in ambient air; default value = 0.2095	True	User
Delay Time Oxygen	The amount of time it takes for the analyzer to respond to a change in oxygen levels.	True	User



ATF-LS-FRL-LI016 Point Source Gas Analysis	ID: 1579 Revision: 4
Authority: Technical Leader	Page: 4 of 5
Original maintained by Quality Programs; copies are uncontrolled.	

**Table 2. “NDIR CO CO2” Data Acquisition Parameters**

Parameter	Parameter Description	Required	Input Method
Calibration Status	Determines if the instrument was in calibration for the experiment.	True	Automatic
Bar Code	The FRL provided bar code for the instrument.	True	User
Serial Number	The manufacturer provided serial number.	True	Automatic
Description	Description of where the exhaust line vents: To Ambient Laboratory or To Test Chamber.	True	User
Location X	In conjunction with a diagram of the experiment set up, this parameter is used to identify the X location in meters of the sample probe	False	User
Location Y	In conjunction with a diagram of the experiment set up, this parameter is used to identify the Y location in meters of the sample probe	False	User
Location Z	In conjunction with a diagram of the experiment set up, this parameter is used to identify the height, in meters, of the sample probe	False	User
Status-Gas Sample Exhaust Return Line	Description of where the exhaust line discharges.	True	User Selectable
Manufacturer	Manufacturer	False	Automatic
Model number	The manufacturer provided model number	False	Automatic
Delay Time CO/CO2	This value is calculated by the calculation program as the test time when the value changed by at least 'initial change amount' from the initial value.	True	User
CO- Time OOS	Indicates the elapsed test time that the instrument was removed. All calculations for the data on the instrument cease at this time.	False	User
CO- Reason OOS	Specifies the reason that the instrument was removed. Reasons typically include damage, impending damage, or test design.	False	User
CO2- Time OOS	Indicates the elapsed test time that the instrument was removed. All calculations for the data on the instrument cease at this time.	False	User
CO2- Reason OOS	Specifies the reason that the instrument was removed. Reasons typically include damage, impending damage, or test design.	False	User
CO Analyzer Full Scale Range	Full scale range that CO measurements were made on	True	User
CO Span Gas Value	CO span gas concentration value (mole/mole) obtained from calibration gas; Default Value = 0.045	True	User



ATF-LS-FRL-LI016 Point Source Gas Analysis	ID: 1579 Revision: 4
Authority: Technical Leader	Page: 5 of 5
Original maintained by Quality Programs; copies are uncontrolled.	

Parameter	Parameter Description	Required	Input Method
CO2 Analyzer Full Scale Range	Full scale range that CO2 measurements were made on	True	User
CO2 Span Gas Value	CO2 span gas concentration value (mole/mole) obtained from calibration gas; Default Value = 0.225	True	User



ATF-LS-FRL-LI017 Laboratory Conditions	ID: 1577 Revision: 4
Authority: Technical Leader	Page: 1 of 7
Original maintained by Quality Programs; copies are uncontrolled.	

## Scope

This Laboratory Instruction covers the use, design, and specifications of the Laboratory Conditions stations that utilize the Vaisala PTU300 Combined Pressure, Humidity and Temperature transmitter with a PTU303 probe. The Laboratory Conditions stations are used by the Bureau of Alcohol, Tobacco, Firearms and Explosives (ATF) Fire Research Laboratory (FRL).

## Instrument Description

### GENERAL

The Vaisala PTU300 transmitter and PTU303 probe measure the ambient pressure, temperature and humidity simultaneously. Figure 1 shows a Vaisala PTU300 transmitter with the PTU303 probe attached beneath the unit. Figure 2 shows an illustration of the interior of the transmitter. The transmitter communicates with the FireTOSS network using Modbus TCP/IP (Ethernet) communication.



**Figure 1. Vaisala PTU300 transmitter and PTU303 probe**

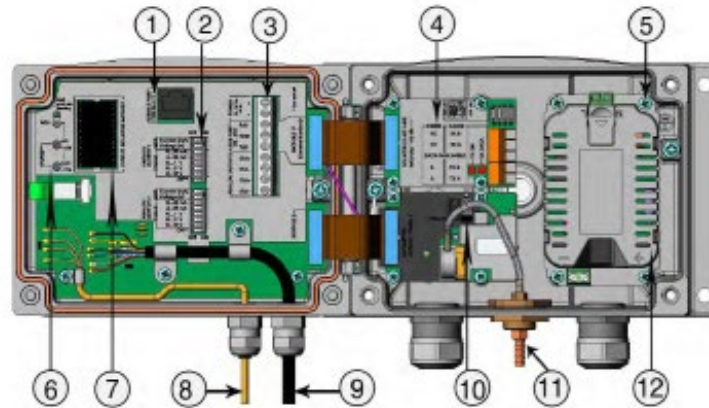

- 1 = Service port (RS-232)
- 2 = DIP switches for analog output settings
- 3 = Power supply and signal wiring screw terminals
- 4 = Relay, RS-422/485, data logger, LAN, WLAN, or analog output module (optional)
- 5 = Grounding connector for power supply module
- 6 = Adjustment buttons (chemical purge buttons) with indicator LED
- 7 = Galvanic isolation module (optional)
- 8 = Temperature probe cable
- 9 = Humidity probe cable
- 10 = BARO-1 module
- 11 = Pressure port
- 12 = Power supply module.

**Figure 2. Interior of the Vaisala PTU300 transmitter [1]**

The Laboratory Conditions station using the Vaisala hardware contains three sensors that measure pressure, humidity, and temperature simultaneously. Barometric pressure measurement is accomplished using a silicon capacitive absolute sensor developed by Vaisala (BAROCAP). The micromechanical sensor uses dimensional changes in its silicon membrane to measure pressure [2]. Humidity measurement is achieved using a capacitive humidity sensor developed by Vaisala (HUMICAP). The capacitance of the thin-film polymer sensor changes as the relative humidity changes [3]. Temperature measurement is attained using a platinum Resistance Temperature Detector (RTD) sensor. The RTD contains a resistor that changes resistance as the temperature changes [4]. The Laboratory Conditions station using the Vaisala hardware requires annual calibration.



ATF-LS-FRL-LI017 Laboratory Conditions	ID: 1577 Revision: 4
Authority: Technical Leader	Page: 3 of 7
Original maintained by Quality Programs; copies are uncontrolled.	

## Uncertainty and Accuracy

The uncertainty in the pressure, temperature, and relative humidity measured by the Laboratory Conditions stations are estimated using the guidelines of the National Institute of Standards and Technology (NIST) Technical Note 1297 [5] and the NIST Uncertainty Workshop [6]. Information about the errors and accuracy of each measurement is obtained from Vaisala, the manufacturer of the Laboratory Condition station hardware [1].

The error for each measurement is assumed to have a rectangular probability distribution, in which case the standard uncertainty is computed by the following equation [5]:

$$u(x) = \frac{e}{\sqrt{3}} \quad (1.1)$$

where,

$u(x)$  = Standard uncertainty  
 $e$  = Error/accuracy of the measurement

Where more than one type of uncertainty is present for a measurement, the values can be combined in quadrature to achieve a combined uncertainty, using the following equation [5-6]:

$$u_c(X) = \sqrt{\sum u(x_i)^2} \quad (1.2)$$

where,

$u_c(X)$  = Combined standard uncertainty  
 $u(x_i)$  = Standard uncertainty component

### **PRESSURE**

Vaisala [1] lists the following values for the error associated with the pressure measurement for a pressure sensor with a range of 500 hPa to 1100 hPa and Class B accuracy:

Linearity:	±0.10 hPa
Hysteresis:	±0.03 hPa
Repeatability:	±0.03 hPa
Calibration Uncertainty:	±0.15 hPa
Accuracy at +20°C:	±0.20 hPa
Temperature dependence:	±0.1 hPa



ATF-LS-FRL-LI017 Laboratory Conditions	ID: 1577 Revision: 4
Authority: Technical Leader	Page: 4 of 7
Original maintained by Quality Programs; copies are uncontrolled.	

Total accuracy (-40°C to +60°C) ±0.25 hPa

Long-term stability/year: ±0.1 hPa

Using Equation 1.1, these errors yield a standard uncertainty for each error/accuracy of measurement as 0.058 hPa, 0.017 hPa, 0.017 hPa, 0.087 hPa, 0.115 hPa, 0.058 hPa, 0.144 hPa, and 0.058 hPa, respectively. The standard uncertainties are combined in quadrature to calculate the combined standard uncertainty for the pressure measurement. The result is a combined standard uncertainty of 22.9 Pa.

$$u_c(P) = \sqrt{0.058^2 + 0.017^2 + 0.017^2 + 0.087^2 + 0.115^2 + 0.058^2 + 0.144^2 + 0.058^2}$$

$$u_c(P) = 0.229 \text{ hPa or } 22.9 \text{ Pa}$$

### **RELATIVE HUMIDITY**

Vaisala [1] lists the following values for the error of the relative humidity measurement:

- Accuracy: ±1% RH for 0-90% RH (+15°C to 25°C)  
±1.7% RH for 90-100% RH (+15°C to 25°C)  
±(1.0% + 0.008 x reading)% RH (-20°C to 40°C)  
±(1.5% + 0.015 x reading)% RH (-20°C to 40°C)
- Calibration Uncertainty: ±0.6% RH (0 to 40% RH)  
±1.0% RH (40 to 97% RH)

It is assumed that under normal operating conditions, the temperature inside the testing area will fall between -20°C to 40°C and that the maximum relative humidity will be 90%. Therefore, the error associated with the accuracy will be ±1.72% RH and the calibration uncertainty will be ±1.0% RH.

Using Equation 1.1, the standard uncertainty for the accuracy and calibration uncertainty are of 0.993% RH and 0.577%, respectively. These values are combined in quadrature to calculate the combined standard uncertainty of the relative humidity measurement. The result is a combined standard uncertainty of 1.1% RH.

$$u_c(\text{RH}) = \sqrt{0.993^2 + 0.577^2} = 1.1 \% \text{ RH} \quad (1.3)$$



ATF-LS-FRL-LI017 Laboratory Conditions	ID: 1577 Revision: 4
Authority: Technical Leader	Page: 5 of 7
Original maintained by Quality Programs; copies are uncontrolled.	

## TEMPERATURE

Vaisala [1] lists the following value for the error associated with the accuracy of the temperature measurement:

- Accuracy:  $\pm 0.2^{\circ}\text{C}$  at  $+ 20^{\circ}\text{C}$

For temperatures other than  $20^{\circ}\text{C}$ , Vaisala provides a chart for the accuracy, as shown in Figure 3. Therefore, assuming a maximum laboratory temperature of  $35^{\circ}\text{C}$  ( $95^{\circ}\text{F}$ ), the accuracy of the temperature measurement would be approximately  $\pm 0.25^{\circ}\text{C}$ .

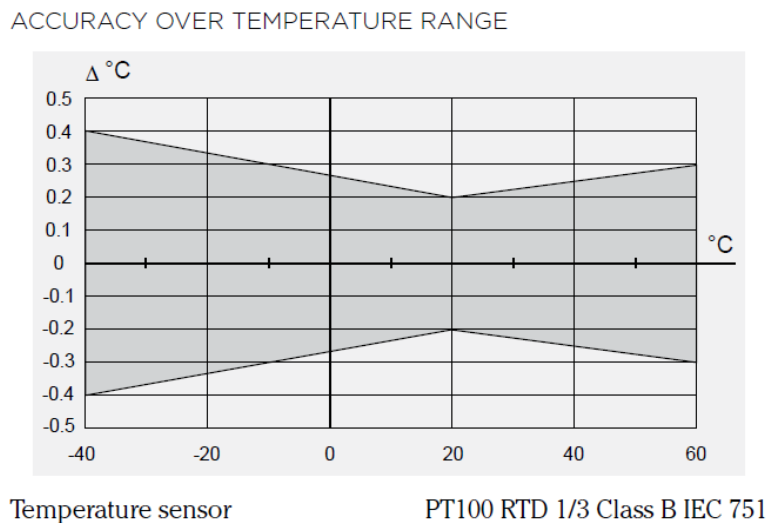

**Figure 3. Accuracy of temperature measurement [1]**

Using Equation 1.1, the standard uncertainty is calculated to be  $0.14^{\circ}\text{C}$ . Because there is only one value listed for the error in the temperature measurement, the combined standard uncertainty is equal to the standard uncertainty of  $0.14^{\circ}\text{C}$ .

$$u_c(T) = \sqrt{0.14^2} = 0.14^{\circ}\text{C} \quad (1.4)$$



ATF-LS-FRL-LI017 Laboratory Conditions	ID: 1577 Revision: 4
Authority: Technical Leader	Page: 6 of 7
Original maintained by Quality Programs; copies are uncontrolled.	

## Operating Instructions

### **REQUIREMENTS**

1. The assigned operator shall be qualified in accordance with laboratory proficiency requirements.
2. The Laboratory Conditions station shall be calibrated and marked with the calibration status in accordance with FRL calibration procedures.
3. The measuring probe shall be clean and free of debris.
4. The pressure port on the bottom of the unit shall be free of any obstructions.

### **PROCEDURE**

The following is the general procedure that shall be followed for using the Laboratory Conditions station.

#### **1. Set up**

- 1.1 The calibration status of the Laboratory Conditions station shall be checked to confirm that the instrument is calibrated.
- 1.2 The Laboratory Conditions station shall be connected to the FireTOSS network.

#### **2. Pre-Test**

- 2.1 Verify that the Laboratory Conditions station is free of debris or any obstacle that would prevent an accurate measurement of the surrounding conditions.

#### **3. Test**

- 3.1 The measurements of the Laboratory Conditions station shall be monitored.

#### **4. Post-Test**

- 4.1 Verify that the data has been collected and that there are no issues with the data collected.
- 4.2 The laboratory condition station shall remain powered and connected to the FireTOSS network.

## Laboratory Conditions Documentation Requirements

The use of a Laboratory Conditions station shall be documented using the FireTOSS experiment design program. Table 1 lists the FireTOSS input parameters for laboratory conditions. The first column provides the input parameter and the second column provides a brief description of that parameter. The third column lists whether the parameter is required in all cases. The fourth column lists how the parameter is entered into the FireTOSS design program.



ATF-LS-FRL-LI017 Laboratory Conditions	ID: 1577 Revision: 4
Authority: Technical Leader	Page: 7 of 7
Original maintained by Quality Programs; copies are uncontrolled.	

**Table 1. Data Acquisition Input Parameters**

Parameter	Description	Required	Input Method
Calibration Status	Determines if the instrument was in calibration for the experiment.	TRUE	Automatic
Description	Description of the location of the laboratory condition station	TRUE	User Input from List
Bar Code	FRL asset number for the laboratory condition station	TRUE	Automatic
Manufacturer	Manufacturer of hardware	TRUE	Automatic
Model	Manufacturer provided model number	TRUE	Automatic
Time Out of Service	Indicates the elapsed test time that the instrument was removed from the test. All calculations for the data on the instrument cease at this time.	FALSE	User
Out of Service Reason	Specifies the reason that the instrument was removed from the experiment. Reasons typically include damage, impending damage, or test design	FALSE	User

## References

1. “User Guide: Vaisala Combined Pressure, Humidity, and Temperature Transmitter PTU300”, M210796EN-H, Vaisala 2015
2. BAROCAP Technology Description, Ref. B210845EN-B, Vaisala 2012
3. HUMICAP Technology Description, Ref. B210781EN-C, Vaisala 2012
4. Morris, Alan, *Measurement & Instrumentation Principles*, Butterworth-Heinemann, Woburn, MA, 2001.
5. Taylor, B. N., & Kuyatt, C. E., “NIST Technical Note 1297: Guidelines for Evaluating and Expressing the Uncertainty of NIST Measurement Results,” National Institute of Standards and Technology, Gaithersburg, MD, 1993.
6. Guthrie, W. & Liu, H., “Hands-on Workshop on Estimating and Reporting Measurement Uncertainty,” National Institute of Standards and Technology, Presentation given to CPSC, 2007.



ATF-LS-FRL-LI018 Combustion Calorimeter	ID: 1572 Revision: 3
Authority: Technical Leader	Page: 1 of 10
Original maintained by Quality Programs; copies are uncontrolled.	

## Scope

This Laboratory Instruction covers the use, design, and specifications of the CWD 2000 Combustion Calorimeter from Union Instruments. The Combustion Calorimeter is used to measure the heat content and specific gravity of natural gas that is used in the Bureau of Alcohol, Tobacco, Firearms and Explosives (ATF) Fire Research Laboratory (FRL) experiments.

## Instrument Description

### *GENERAL*

The purpose of the Combustion Calorimeter is to measure the calorific value and specific gravity of the natural gas entering the building. Figure 1 shows a photograph of the instrument.



**Figure 1: Combustion Calorimeter Mounted to Wall in 1 Megawatt Shed**

The Combustion Calorimeter has a built in specific gravity measurement cell. Sample gas flows through the measuring chamber where a membrane vibrates at a constant frequency. Oscillations are transferred through the gas to a transducer. The amplitude of these oscillations is directly proportional to the density of the gas.

The calorific value is measured by way of a thermopile measuring system. Sample gas passes through a Wobbe range orifice and is burned at atmospheric pressure. The hot gases are mixed with a cooling airflow and the temperature of the mix is measured by thermopile hot junctions. The cold junction of the thermopile measures the temperature of the incoming cool air flow,



ATF-LS-FRL-LI018 Combustion Calorimeter	ID: 1572 Revision: 3
Authority: Technical Leader	Page: 2 of 10
Original maintained by Quality Programs; copies are uncontrolled.	

which results in a pressure difference that is proportional to the Wobbe Index of the gas. To calculate the calorific value, the following relation is used by the Combustion Calorimeter [1]:

$$\text{Calorific Value} = \text{Wobbe Index} \sqrt{\text{Specific Gravity}}$$

Additional technical information regarding the theory behind the use of the Combustion Calorimeter can be found in the “*Users Manual – CWD 2000 Combustion Calorimeter – For high speed measurement of fuel gases*”. [1]

### **SYSTEM COMPONENTS**

The major components of the Combustion Calorimeter are listed below and are indicated in Figure 2. Note that components with an asterisk (\*) are not shown in the figure. See the Combustion Calorimeter user’s manual for a diagram showing their location. [1]

- |  |  |
|--|--|
| 1. Differential pressure for density cell (positive) | 17 - Discharge (exhaust) pipe  |
| 2. Differential pressure for density cell (negative) | 18 - Solenoid valve for calibration gas                              |
| 3. Differential pressure for air (negative)          | 19 - Solenoid valve for process gas                                  |
| 4. Differential pressure for air (positive)          | 20 - Specific gravity cell   |
| 5. Gas pressure at range orifice (Wobbe jet)         | 21 - Pressure regulator for process gas                              |
| 6. Power supply*                                     | 22 - Precision pressure regulator                                    |
| 7. PC 104type processor circuit board*               | 23 - Pressure regulator, specific gravity cell differential pressure |
| 8. Disk drive  | 24 - Range orifice (Wobbe jet) location                              |
| 9. Filter element for air supply*                    | 25 - Primary air supply tube   |
| 10. Pt 100 temp correction                           | 26 - E/A internal  |
| 11. Pt 100 temp correction                           | 27 - Temperature sensor  |
| 12. Ignition electrode                               | 28 - Door switch   |
| 13. Burner   | 29 - Terminal block for line power supply                            |
| 14. Electrical noise filter                          | 30 - Output signal PG cord connector                                 |
| 15. Air fan  | 31 - Line power PG cord connector                                    |
| 16. Frequency controller for air fan                 | 32 - E/A Extern  |

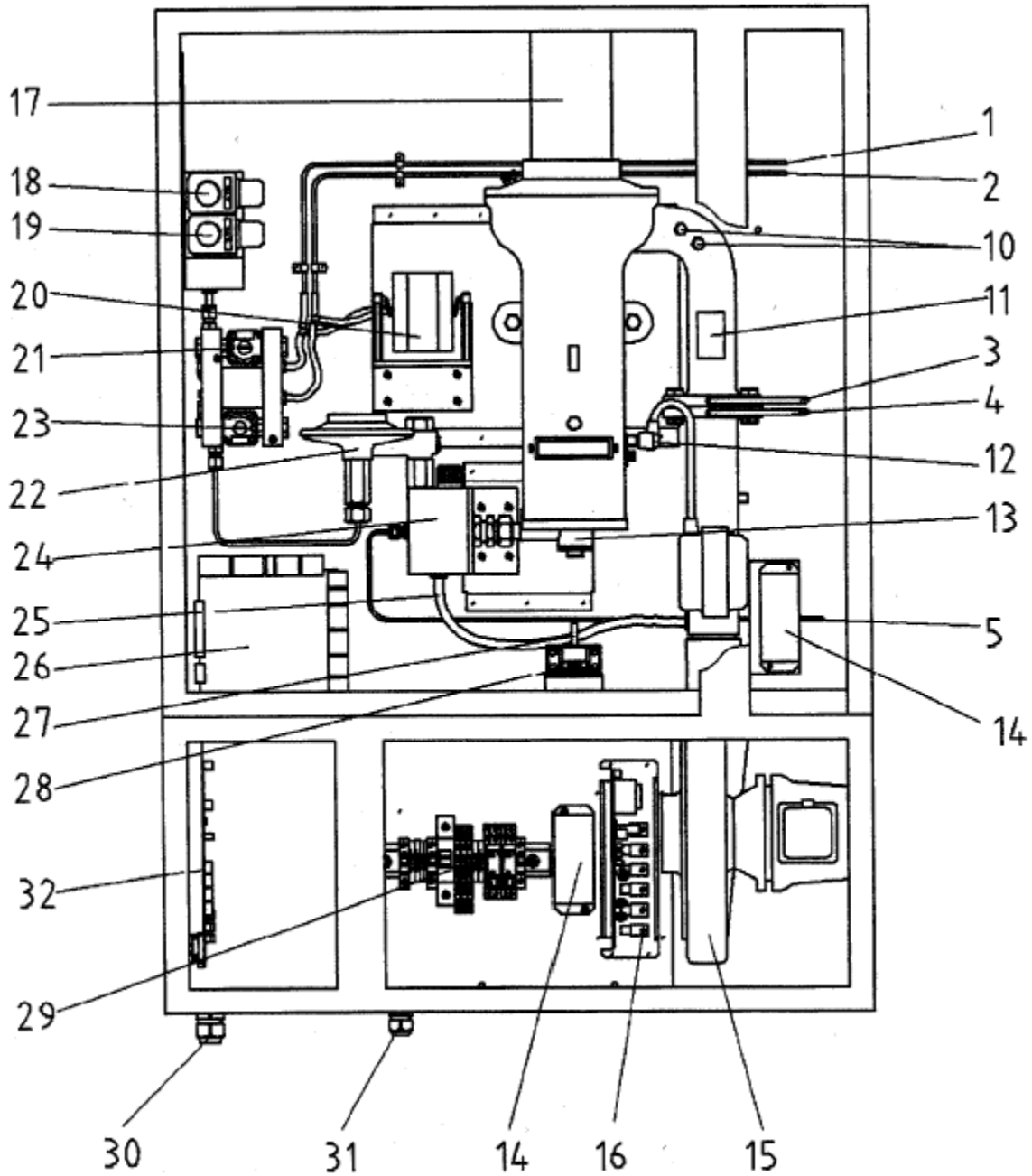

Figure 2: Inside View of CWD 2000 Combustion Calorimeter [1]



ATF-LS-FRL-LI018 Combustion Calorimeter	ID: 1572 Revision: 3
Authority: Technical Leader	Page: 4 of 10
Original maintained by Quality Programs; copies are uncontrolled.	

## FireTOSS Calculations

The Combustion Calorimeter instrument in FireTOSS provides a data output of calorific value ( $C.V_{dry}$ ) and specific gravity of natural gas ( $SG_{NG}$ ) relative to air.

The density of the natural gas is calculated from the specific gravity of natural gas using the following equation:

$$\rho_{NG} = \rho_{Air} * SG_{NG} \quad (1.1)$$

where,

- $\rho_{NG}$  = density of natural gas ( $\text{kg/m}^3$ )
- $\rho_{Air}$  = density of ambient air ( $\text{kg/m}^3$ )
- $SG_{NG}$  = specific gravity of natural gas relative to air

For Equation 1.1, the density of ambient air is calculated using the FRL Laboratory Conditions measurements of ambient pressure and temperature [2].

In addition, the heat of combustion for the natural gas is calculated using the following equation:

$$\Delta H_{c,gross} = \frac{C.V_{dry}}{\rho_{NG}} \quad (1.2)$$

where

- $\Delta H_{c,gross}$  = gross heat of combustion of the gas mixture in MJ/kg
- $C.V_{dry}$  = calorific value (dry) of natural gas in  $\text{MJ/m}^3$
- $\rho_{NG}$  = density of natural gas in  $\text{kg/m}^3$

Equation 1.2 yields a value in terms of the dry calorific value, which does not account for water vapor. To account for water vapor, a correlation from Bossel [3] was used to convert to the net heat of combustion. This correlation was empirically developed and is specific for natural gas.

$$\Delta H_{c,net} = \Delta H_{c,gross} * 0.896 \quad (1.3)$$

## Uncertainty

When operated within the guidelines specified in this document and within the User's Manual [1], the Combustion Calorimeter functions within the following limits:

- Accuracy: +/- 1.0% for CV or Wobbe Index  
+/- 0.8% for Specific Gravity
- Linearity: +/- 0.2%
- Repeatability: +/- 0.5%



ATF-LS-FRL-LI018 Combustion Calorimeter	ID: 1572 Revision: 3
Authority: Technical Leader	Page: 5 of 10
Original maintained by Quality Programs; copies are uncontrolled.	

In order to function within these limits, the Combustion Calorimeter must be kept in an ambient temperature of between 10°C and 38°C (50°F to 100°F) with a rate of change of no more than +/- 2°C (3.6°F) per hour. Further, the ambient temperature should be within +/-7°C (12.6°F) of the temperature at which calibration was performed. This data is tracked and recorded using a temperature sensor connected to data acquisition. The data recorded is analyzed and the operator is alerted if the temperature trend is outside of tolerance.

The Combustion Calorimeter is used to calculate the density and heat of combustion of the natural gas. A standard uncertainty for these two values can be determined by the accuracy given by the User's Manual and a set of data taken from the Combustion Calorimeter. The uncertainty of these measurements was calculated using the guidelines of the National Institute of Standards and Technology (NIST) Technical Note 1297 [4], Special Publication 1007 [5] and the NIST Uncertainty Workshop [6], using the following equation:

$$u_c(y) = \sqrt{\sum s_i^2 u(x_i)^2} \quad (1.4)$$

where:

$u_c(y)$  = Combined standard uncertainty of the quantity being calculated

$u(x_i)$  = Standard uncertainty of each component that is used in the calculation of  $y$

$s_i$  = Sensitivity coefficient  $(\partial y / \partial x_i)$

### **DENSITY**

The combustion calorimeter measures the specific gravity of the process gas (natural gas) relative to air at ambient conditions. The uncertainty in the specific gravity measurement can be calculated based on the specifications of the instrument and an analysis of scatter in the data. In order to evaluate the natural gas density, Equation 1.1 is used with  $\rho_{\text{air}}$  being calculated from the measured ambient conditions.

Applying Equation 1.4 to Equation 1.1 yields:

$$u_c(\rho_{\text{NG}}) = \sqrt{(SG_{\text{NG}})^2 (u(\rho_{\text{air}}))^2 + (\rho_{\text{air}})^2 (u(SG_{\text{NG}}))^2} \quad (1.5)$$

The uncertainty of the specific gravity has two parts: the uncertainty of the combustion calorimeter and the fluctuations over time. The uncertainty in the combustion calorimeter is a function of the accuracy, linearity, and repeatability of the instrument.

Union Instruments gives the accuracy of the combustion calorimeter specific gravity measurement as  $\pm 0.8$  % full scale [1], or 0.018 at the 0.2 -2.2 range setting. The linearity is listed as  $\pm 0.2$  % full scale and the repeatability is listed as  $\pm 0.5$  % full scale. It can be assumed that these errors have a rectangular probability distribution, in which case the standard



ATF-LS-FRL-LI018 Combustion Calorimeter	ID: 1572 Revision: 3
Authority: Technical Leader	Page: 6 of 10
Original maintained by Quality Programs; copies are uncontrolled.	

uncertainty is computed by dividing each component by  $\sqrt{3}$  [4]. The standard uncertainties of these components are then, 0.01, 0.0025, and 0.0064, respectively.

The uncertainty over time can be calculated using a 30 day average standard deviation. NIST [4] states that for a sample of data, the uncertainty of the samples is:

$$U_s = \sigma / \sqrt{n} \quad (1.6)$$

where:

- $U_s$  = Standard uncertainty of the samples
- $\sigma$  = Standard deviation of the samples
- $n$  = Number of samples

Using this formula, the uncertainty of the specific gravity samples can be determined. Over a sample of 30 data points, the standard deviation was 0.002, which yields 0.0004 as the standard uncertainty.

The uncertainty components can be combined in quadrature to estimate the combined uncertainty of the specific gravity measurement. The result is  $u(SG_{NG}) = \underline{0.012}$ .

Air can be treated as an ideal gas, in which case the density is expressed as:

$$\rho = \frac{P}{RT} \quad (1.7)$$

where:

- $\rho$  = gas density ( $\text{kg/m}^3$ )
- $P$  = gas pressure (kPa)
- $R$  = gas constant (0.287 kJ/kg/K for air)
- $T$  = gas temperature (K)

Uncertainty in the air density is a function of the Laboratory Conditions temperature and pressure measurements. Standard uncertainties for the temperature (0.14°C) and pressure (0.023 kPa) were computed based on an evaluation of the Lab Conditions measurements [2].

Uncertainty in the air density is calculated by applying Equation 1.4 to Equations 1.7.

$$u_c(\rho_{\text{air}}) = \sqrt{\left(\frac{1}{RT}\right)^2 (u(P))^2 + \left(\frac{P}{RT^2}\right)^2 (u(T))^2} \quad (1.8)$$

From Equation 1.8, the uncertainty in the density of air is 0.001  $\text{kg/m}^3$ . Using Equation 1.5, the uncertainty in the natural gas density is then  $u(\rho_{NG}) = \underline{0.014 \text{ kg/m}^3}$ . This corresponds to a relative standard uncertainty of 2.5 % at the 30 day average specific gravity of 0.593.



ATF-LS-FRL-LI018 Combustion Calorimeter	ID: 1572 Revision: 3
Authority: Technical Leader	Page: 7 of 10
Original maintained by Quality Programs; copies are uncontrolled.	

### ***HEAT OF COMBUSTION***

Substituting Equations 1.1 and 1.2 into Equation 1.3 and applying Equation 1.4 yields:

$$u_c(\Delta H_{c,net}) = \sqrt{\left(\frac{0.896}{\rho_{air} SG_{NG}}\right)^2 (u(C.V.))^2 + \left(\frac{-0.896 C.V.}{\rho_{air} SG_{NG}^2}\right)^2 (u(SG_{NG}))^2 + \left(\frac{-0.896 C.V.}{\rho_{air}^2 SG_{NG}}\right)^2 (u(\rho_{air}))^2} \quad (1.9)$$

The uncertainty of the heat of combustion is a function of the uncertainty of both the specific gravity and calorific value measurements from the combustion calorimeter. The specific gravity uncertainty was calculated above. The calorific value uncertainty is comprised of two parts: the uncertainty of the combustion calorimeter and the variance over time. The uncertainty in the combustion calorimeter is a function of the accuracy, linearity and repeatability of the instrument.

The combustion calorimeter manufacturer gives the accuracy of the combustion calorimeter heating value measurement as 1% of full scale [1]. The linearity is listed as  $\pm 0.2\%$  and the repeatability is listed as  $\pm 0.5\%$ . It can be assumed that these errors have a rectangular probability distribution, in which case the standard uncertainty is computed by dividing each component by  $\sqrt{3}$  [4]. At the 35-45 MJ/m<sup>3</sup> range, the standard error associated with the accuracy is 0.26 MJ/m<sup>3</sup>. The standard errors associated with the linearity and repeatability are calculated similarly to be 0.05 MJ/m<sup>3</sup> and 0.13 MJ/m<sup>3</sup>, respectively.

The uncertainty over time can be calculated from Equation 1.4, using the 30 day average standard deviation. This yields a standard error of 0.028 for the variation of the measurement.

The uncertainty components can be combined in quadrature to estimate the combined uncertainty of the calorific value measurement. The result is  $u(C.V.) = 0.295 \text{ MJ/m}^3$ . This corresponds to a standard relative uncertainty in the calorific value of 0.8% based on the 30 day average of 38.5 MJ/m<sup>3</sup>. From Equation 1.9, the combined standard uncertainty in the natural gas heat of combustion is then  $u_c(\Delta H_{c,net}) = 1.05 \text{ MJ/kg}$ .



ATF-LS-FRL-LI018 Combustion Calorimeter	ID: 1572 Revision: 3
Authority: Technical Leader	Page: 8 of 10
Original maintained by Quality Programs; copies are uncontrolled.	

## Operating Instructions

### *REQUIREMENTS*

1. The assigned operator shall be qualified in accordance with laboratory proficiency requirements.
2. The instrument shall be calibrated in accordance with FRL calibration procedures.
3. If data acquisition is used, the data acquisition equipment shall be calibrated and be marked with the calibration status in accordance with FRL calibration procedures.

### *PROCEDURE*

The following is the general procedure that shall be followed. The operator shall also be properly trained on all appropriate procedures.

#### **1. Set up**

- 1.1. The certification date on the calibration gas shall be checked to confirm that the gas certification has not expired.
  - 1.1.1. If the instrument is being powered up, a calibration shall be performed.
- 1.2. The instrumentation shall be connected to the data acquisition hardware using the smallest voltage input range that will bound the output range of the instrument.
- 1.3. Ensure that adequate fuel pressure is available.

#### **2. Pre-Test**

- 2.1. The pilot flame shall be verified to be lit.
- 2.2. All valves leading to the instrument shall be verified as “OPEN”.
- 2.3. It shall be verified that a calibration has been performed and the environmental temperature requirements have been met.

#### **3. Test**

- 3.1. The display on the instrument shall show a stability reading (“STAB”) of less than 0.15 to signify a stable reading.
- 3.2. The data shall be monitored to verify continuity.

#### **4. Post Test**

- 4.1. No action shall be taken other than to verify that the instrument is still yielding stable readings.
- 4.2. The instrument shall be left in the “ON” position.



ATF-LS-FRL-LI018 Combustion Calorimeter	ID: 1572 Revision: 3
Authority: Technical Leader	Page: 9 of 10
Original maintained by Quality Programs; copies are uncontrolled.	

## Combustion Calorimeter Documentation Requirements

The Combustion Calorimeter can be used as a stand-alone instrument in FireTOSS. The information that the user shall document about the FPC is shown in Table 1. The first column in Table 1 shows the description of input parameter that will appear in the column heading of the FireTOSS experiment design program. The second column in Table 1 shows whether the parameter is required in all cases, and the third column describes the method by which the field for each parameter is filled.

**Table 1: Combustion Calorimeter Data Acquisition Input Parameters**

Parameter	Required	Input Method
Calibration Status	True	Automatically updated
Description	False	User input
Bar Code	True	User input from list
Model Number	True	Automatically updated
Manufacturer	True	Automatically updated
Serial Number	True	Automatically updated
Time Out of Service	False	User input
Out of Service Reason	False	User input

Note that the Combustion Calorimeter is also included as part of the *Burner Gas Train* object in FireTOSS. However, all the information related to the instrument is added automatically.



ATF-LS-FRL-LI018 Combustion Calorimeter	ID: 1572 Revision: 3
Authority: Technical Leader	Page: 10 of 10
Original maintained by Quality Programs; copies are uncontrolled.	

## References

1. "Users Manual – CWD 2000 Combustion Calorimeter – For high speed measurement of fuel gases" Union, 2007.
2. ATF FRL Instruction, "Laboratory Instruction LI017: Laboratory Conditions.
3. Bossel, U., "Well-to-Wheel Studies, Heating Values, and the Energy Conservation Principle," Oberrohrdorf, Switzerland, 2003. <http://www.efcf.com/reports/E10.pdf>
4. Taylor, B. N., & Kuyatt, C. E., "NIST Technical Note 1297: Guidelines for Evaluating and Expressing the Uncertainty of NIST Measurement Results," National Institute of Standards and Technology, Gaithersburg, MD 1993.
5. Bryant, A.R., Ohlemiller, T.J., Johnsson, E.L, Hamins, A., Grove, B.S., Guthrie, W.F., Maranghides, A., Mulholland, G.W., "Special Publication 1007," National Institute of Standards and Technology, Gaithersburg, MD 2003.
6. Guthrie, W. & Liu, H., "Hands-on Workshop on Estimating and Reporting Measurement Uncertainty," National Institute of Standards and Technology, Presentation given to CPSC, 2007.



ATF-LS-FRL-LI019 Weighing Devices	ID: 2137 Revision: 5
Authority: Technical Leader	Page: 1 of 13
Original maintained by Quality Programs; copies are uncontrolled.	

## Scope

This laboratory instruction covers the use, design and specifications of Weighing Devices used in the Bureau of Alcohol, Tobacco, Firearms and Explosives (ATF) Fire Research Laboratory (FRL).

## Instrument Description

### GENERAL

Weighing devices are instruments primarily used to measure the instantaneous mass of an object or to observe changes in the mass over a period of time. Weighing devices can be classified as scales or balances. Scales measure the physical change in the shape and/or the position of the scale as a result of a weight being applied to the scale. Balances use a counteractive force, typically an electromagnetic force, to maintain the original shape and/or position of the balance when a weight is applied to the balance.

Weighing devices usually consist of three main components: the load cell(s), a weighing platform, and an indicator unit.

### Load Cells

A load cell is a device that produces an electrical response proportional the force induced by a mass positioned on a weighing device. Many weighing devices use load cells that utilize either strain gauge or magnetic force restoration (MFR) methods.

### Strain Gauge Load Cell

Strain gauge load cells use strain gauges that are positioned along a structural member of the load cell in a specific configuration for the application. Many scales contain strain gauge-based load cells. Most strain gauges are bonded to the load cell in the manner represented in Figure 1.

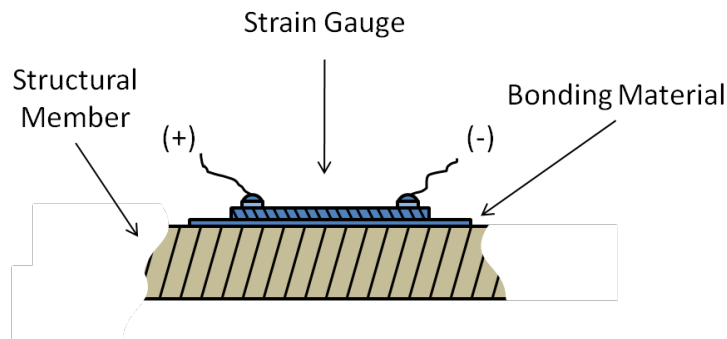

**Figure 1. Strain gauge bonded to the structural member of a load cell**

A common configuration is the use of a Wheatstone bridge containing four strain gauges, a full-bridge, to complete an electrical circuit as shown in Figure 2.

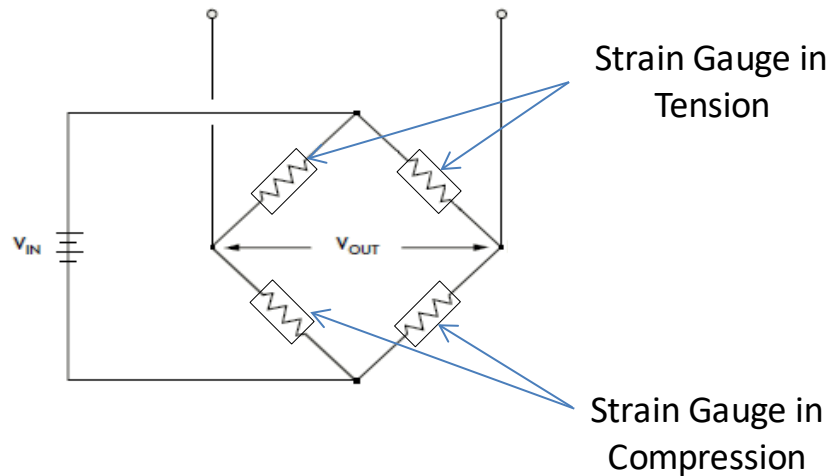

**Figure 2. Wheatstone bridge circuit with a full-bridge configuration**

A full-bridge configuration has many advantages including: a voltage output directly proportional to the applied load, a greater sensitivity than configurations with fewer strain gauges, and the ability to allow adverse temperature effects on the strain gauges to cancel out [1]. The strain gauges are positioned on the structural member allowing two gauges to each measure in tension and compression, shown in Figure 3.

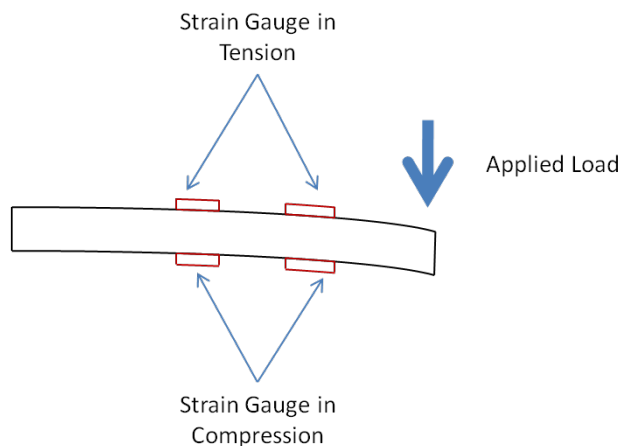

**Figure 3. Position of strain gauges on a load cell in full-bridge configuration**

Unstressed, the strain gauges are all of equal resistance and the output voltage of the circuit is zero. Tensioning and compressing a strain gauge increases and decreases the electrical resistance, respectively, of the strain gauge. When a load is applied to the load



ATF-LS-FRL-LI019 Weighing Devices	ID: 2137 Revision: 5
Authority: Technical Leader	Page: 3 of 13
Original maintained by Quality Programs; copies are uncontrolled.	

cell, the structural member deforms and tenses two of the strain gauges while compressing the other two. This causes an imbalance in the electrical circuit and generates an output voltage directly proportional to the load applied to the load cell. Voltage measurements are generally less precise, but greater integrity in the structural member of the load cell allows for weighing objects with larger masses.

### *Magnetic Force Restoration Load Cell*

MFR load cells use a force generated by an electromagnet to counteract the applied load. Many balances contain MFR-based load cells. When there is no applied load, the balance is in equilibrium and equal amounts of current pass through the negative and positive coils on the electromagnet. The weighing platform sinks under an applied load and unbalances the system. This imbalance activates a sensor that increases and decreases the current passing through the positive and negative coils, respectively. This current imbalance generates a magnetic field, creating magnetic force that repels the magnetically reactive weighing platform until the balance returns to equilibrium, as shown in Figure 4.

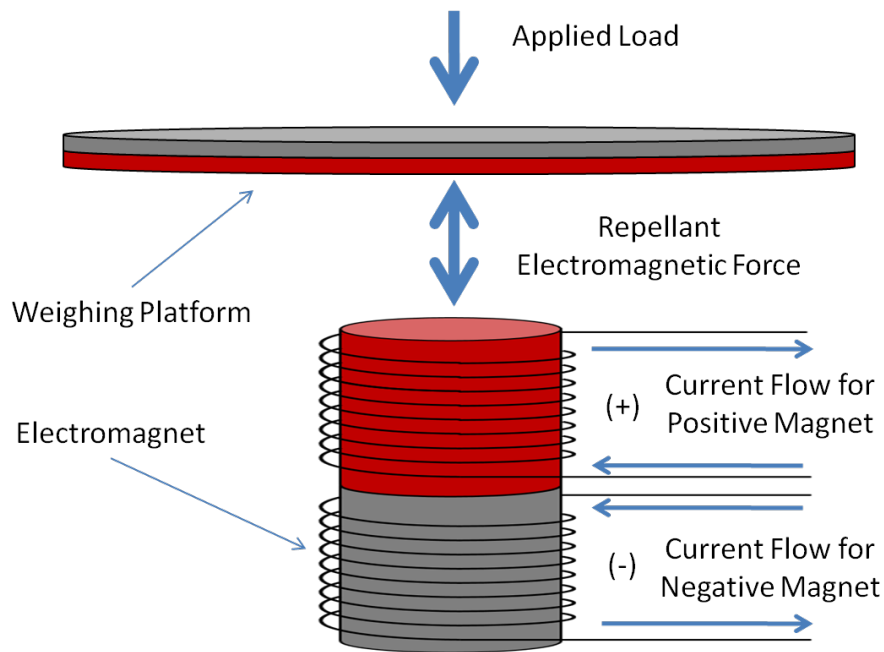

**Figure 4. Schematic of electromagnet maintaining equilibrium in an MFR**

The current differential between the two coils necessary for the electromagnet to maintain equilibrium is proportional to the applied load. Current measurements usually offer greater precision but limitations in the strength of the electromagnet confine MFR load cells to weighing objects with smaller masses.



ATF-LS-FRL-LI019 Weighing Devices	ID: 2137 Revision: 5
Authority: Technical Leader	Page: 4 of 13
Original maintained by Quality Programs; copies are uncontrolled.	

## Weighing Platforms

The weighing platform on a weighing device is used to support or contain an object during measurements and distribute the force caused by the objects mass to the load cell(s). Weighing platforms vary in size, shape, material, and load capabilities depending of the application of the weighing device. Some weighing platforms provide an additional apparatus to contain the object during mass measurements and reduce environmental interference. Objects are generally positioned on the weighing platform so that the center of mass of the object coincides with the center of the weighing platform.

## Indicator

Indicators are devices that provide a readable display of the electronic output of the load cell readings. The analog signal from the load cell(s) is amplified and transmitted to an A/D converter where the signal is converted to a discrete digital number proportional to the magnitude of the analog signal. The digital signal is transmitted to a processor which computes and outputs the measurement value to the display and peripheral interfaces.

Prior to taking measurements, the weighing device must be zeroed with no load present to ensure accurate measurements. This action compensates for any existing environmental conditions that offset the measurement readings. Most indicators provide functions to zero, tare, and offset the measurement readings, as well as configuration options to adjust the preferred units of the measurements, such as conversions between weight and mass measurements.

Many weighing devices have indicators with adjustable measurement capabilities defined by the capacity of the weighing device and the number of available discrete values, or divisions, provided by the indicator. Typical indicators have between 256 and 10,000 divisions. Adjusting the capacity on the indicator redefines the readability, the capacity divided by the number of divisions, of a weighing device. Adjusting the indicator to lower capacity settings allows for more precise measurements.

## **Data Acquisition**

Most indicators include output connections to connect peripheral devices such as the FRL Data Acquisition (DAQ) system. One connection type is an RS-232 communication interface which is used to transmit the weight and time to a recording device such as a computer or printer. RS-232 connections usually consist of DB9 serial (9-pin) or DB25 parallel (25-pin) communication ports. On some models, there is an option to install an analog output board, which converts the discrete digital number on the indicator display to an analog signal. Another option is an Ethernet output board. This allows direct connection to the FRL DAQ system through an Ethernet cable. This board's output will match the output on the indicator. The timestamp for the data is derived from the FRL DAQ system's time.



ATF-LS-FRL-LI019 Weighing Devices	ID: 2137 Revision: 5
Authority: Technical Leader	Page: 5 of 13
Original maintained by Quality Programs; copies are uncontrolled.	

## Uncertainty and Accuracy

In the United States, the field of weights and measures is generally governed by the National Institute of Standards and Technology (NIST) Handbook 44 document [2]. Handbook 44 divides weighing devices into accuracy classes I, II, III, III L, and IIII according to the number of scale divisions and the value of the verification scale divisions as shown in Figure 5. The verification scale division (e) should not be confused with the scale division (d). Although they are often times the same, a weighing device may have more scale divisions than the number of verification scale divisions. In Legal for Trade (LFT) applications, the accuracy or resolution of a weighing device must be set in accordance with the accuracy class for which it was certified. However, weighing devices often have flexible resolution modes to accommodate non-LFT or industrial applications. In standard or industrial mode, the resolution can be configured based on the sensitivity and measurement range of the load cell(s) and the quality of the indicator unit.



ATF-LS-FRL-LI019 Weighing Devices	ID: 2137 Revision: 5
Authority: Technical Leader	Page: 6 of 13
Original maintained by Quality Programs; copies are uncontrolled.	

<i>Table 3. Parameters for Accuracy Classes</i>			
<i>Class</i>	<i>Value of the Verification Scale Division (d or e<sup>1</sup>)</i>	<i>Number of Scale<sup>4</sup> Divisions (n)</i>	
		<i>Minimum</i>	<i>Maximum</i>
<i>SI Units</i>			
<i>I</i>	<i>equal to or greater than 1 mg</i>	<i>50 000</i>	<i>--</i>
<i>II</i>	<i>1 to 50 mg, inclusive</i>	<i>100</i>	<i>100 000</i>
	<i>equal to or greater than 100 mg</i>	<i>5 000</i>	<i>100 000</i>
<i>III<sup>2,5</sup></i>	<i>0.1 to 2 g, inclusive</i>	<i>100</i>	<i>10 000</i>
	<i>equal to or greater than 5 g</i>	<i>500</i>	<i>10 000</i>
<i>III L<sup>3</sup></i>	<i>equal to or greater than 2 kg</i>	<i>2 000</i>	<i>10 000</i>
<i>III</i>	<i>equal to or greater than 5 g</i>	<i>100</i>	<i>1 200</i>
<i>Inch-Pound Units</i>			
<i>III<sup>5</sup></i>	<i>0.0002 lb to 0.005 lb, inclusive</i>	<i>100</i>	<i>10 000</i>
	<i>0.005 oz to 0.125 oz, inclusive</i>	<i>100</i>	<i>10 000</i>
	<i>equal to or greater than 0.01 lb</i>	<i>500</i>	<i>10 000</i>
	<i>equal to or greater than 0.25 oz</i>	<i>500</i>	<i>10 000</i>
<i>III L<sup>3</sup></i>	<i>equal to or greater than 5 lb</i>	<i>2 000</i>	<i>10 000</i>
<i>III</i>	<i>greater than 0.01 lb</i>	<i>100</i>	<i>1 200</i>
	<i>greater than 0.25 oz</i>	<i>100</i>	<i>1 200</i>
<p><sup>1</sup> For Class I and II devices equipped with auxiliary reading means (i.e., a rider, a vernier, or a least significant decimal differentiated by size, shape, or color), the value of the verification scale division "e" is the value of the scale division immediately preceding the auxiliary means.</p> <p><sup>2</sup> A scale marked "For prescription weighing only" may have a verification scale division (e) not less than 0.01 g. (Added 1986) (Amended 2003)</p> <p><sup>3</sup> The value of a scale division for crane and hopper (other than grain hopper) scales shall be not less than 0.2 kg (0.5 lb). The minimum number of scale divisions shall be not less than 1000.</p> <p><sup>4</sup> On a multiple range or multi-interval scale, the number of divisions for each range independently shall not exceed the maximum specified for the accuracy class. The number of scale divisions, n, for each weighing range is determined by dividing the scale capacity for each range by the verification scale division, e, for each range. On a scale system with multiple load-receiving elements and multiple indications, each element considered shall not independently exceed the maximum specified for the accuracy class. If the system has a summing indicator, the n<sub>max</sub> for the summed indication shall not exceed the maximum specified for the accuracy class. (Added 1997)</p> <p><sup>5</sup> The minimum number of scale divisions for a Class III Hopper Scale used for weighing grain shall be 2000. (Added 2004)</p>			

**Figure 5. Excerpt of NIST Handbook 44 summarizing the parameters for different accuracy classes**

In more specific cases, some weighing devices adhere to custom specifications not presented by the general guidelines in NIST Handbook 44. These weighing devices adhere to the calibration procedures outlined in NIST Handbook 44 with adjusted accuracy standards according to the manufacturer's specifications. These specific accuracy standards are usually more stringent than the standards supplied in NIST



ATF-LS-FRL-LI019 Weighing Devices	ID: 2137 Revision: 5
Authority: Technical Leader	Page: 7 of 13
Original maintained by Quality Programs; copies are uncontrolled.	

Handbook 44 and generally apply to weighing devices that perform very precise measurements.

The following components of measurement error, as determined by tolerances outlined in the manufacturer's specifications or NIST Handbook 44, are considered in the uncertainty analysis of a weighing device:

- Tolerance
- Readability
- Linearity
- Hysteresis
- Repeatability
- Creep
- Sensitivity
- Temperature effects on minimum dead load output
- Temperature effects on sensitivity

The measurement uncertainty for a weighing device was determined using guidelines in the NIST Technical Note 1297 [3], Special Publication 1007 [4], and the NIST Uncertainty Workshop [5]. The uncertainty of mass measurements includes the allowable uncertainty, random uncertainty, and combined uncertainty.

### **ALLOWABLE UNCERTAINTY**

The allowable uncertainty is determined from allowable tolerances provided in the manufacturer's specifications and NIST Handbook 44. The allowable tolerances defined by the manufacturer are:

- Measurement tolerance
- Linearity
- Repeatability

Additional allowable tolerances mandated by NIST Handbook 44 are:

- Zero balance
- Sensitivity
- Temperature effect on the minimum dead load output over a temperature change of 5°C

The error associated with each tolerance,  $T$ , assumes a rectangular probably distribution and can be calculated by dividing the tolerance by  $\sqrt{3}$ . The allowable uncertainty,  $U_A$ , can be calculated by combining the error components in quadrature using Equation 1.1.



$$U_A = \sqrt{\sum \left(\frac{T}{\sqrt{3}}\right)^2} \quad (1.1)$$

### ***RANDOM UNCERTAINTY***

The random uncertainty,  $U_R$ , is determined from random errors that occur naturally during operation. The errors are determined using sample measurements taken during typical test conditions. The random uncertainty is calculated by applying the standard deviation,  $S$ , and the number of measurements,  $n$ , in a sample to Equation 1.2.

$$U_R = \frac{S}{\sqrt{n}} \quad (1.2)$$

### ***COMBINED UNCERTAINTY***

The combined uncertainty,  $U_C$ , is determined from the combining the allowable uncertainty and random uncertainty in quadrature. The combined uncertainty is calculated using Equation 1.3.

$$U_C = \sqrt{(U_A^2 + U_R^2)} \quad (1.3)$$

## **Operating Instructions**

### ***REQUIREMENTS***

1. The assigned operator shall be qualified in accordance with laboratory proficiency requirements.
2. The weighing device and data acquisition (if applicable) instrumentation shall be calibrated and marked with the calibration status in accordance with FRL calibration procedures.
3. The weighing device shall be installed in an area that minimizes excess air currents, vibration, and drastic temperature or humidity changes.
4. The weighing device shall be within manufacturer recommended operating temperature range.
5. The weighing device shall be acclimated to the environment.



ATF-LS-FRL-LI019 Weighing Devices	ID: 2137 Revision: 5
Authority: Technical Leader	Page: 9 of 13
Original maintained by Quality Programs; copies are uncontrolled.	

## **PROCEDURE**

### **1. Pre-Test**

- 1.1. Level the weighing device.
- 1.2. Connect power to the weighing device
  - 1.2.1. Manufacturer may require the power to be connected for an extended period of time before measurements. Consult manufacturer documentation.
- 1.3. Run all data acquisition cords perpendicular to the power cord to minimize signal interference.
- 1.4. Zero the weighing device
  - 1.4.1. If applicable, place weighting container onto the platform and tare the weighing device before applying load.
- 1.5. Center the object on the loading platform.

### **2. During the Test**

- 2.1. The output of the weighing device shall be recorded for the duration of the experiment.
  - 2.1.1. Exception – When the weighing device must be removed prior to the end of the experiment due to experiment design or damage. The elapsed time at which the instrument was removed and the reason for removal shall be recorded.
  - 2.1.2. Exception- If the weighing device is used for a single point measurement, the display reading shall be documented in the datasheet or with a photo of the digital display.
    - 2.1.2.1. In the case of single point measurements, wait for readings to stabilize before recording mass measurements.

### **3. Post Test**

- 3.1. After the experiment, the weighing device shall be examined for visible damage.
  - 3.1.1. If damage has occurred, the instrument shall be taken out of service at the time of the damage.
  - 3.1.2. The laboratory engineer shall review the data to determine if there is a noticeable event that marked the damage to the instrument. If not, the instrument shall be taken out of service for the entire test.
- 3.2. Clean the platform of debris or residue.



ATF-LS-FRL-LI019 Weighing Devices	ID: 2137 Revision: 5
Authority: Technical Leader	Page: 10 of 13
Original maintained by Quality Programs; copies are uncontrolled.	

## Weighing Device Documentation Requirements

A weighing device shall be documented using the FireTOSS experiment design program. The required information that the user must document when using the weighing device in an experiment is shown in Table 1. The first column provides the input parameter, and the second column provides a brief description of that parameter. The third column lists whether the parameter is required in all cases. The fourth column lists how the parameter is entered into the FireTOSS design program.

**Table 1. Data Acquisition Input Parameters**

Parameter	Parameter Description	Required	Input Method
Calibration Status	Determines if the instrument was in calibration for the experiment.	TRUE	Automatic
Bar Code	FRL asset number for the load cell	TRUE	User Selectable from List
Description	Description of the load cell	FALSE	Automatic
Manufacturer	Manufacturer	TRUE	Automatic
Serial Number	The manufacturer provided serial number	TRUE	Automatic
Model Number	The manufacturer provided model number	TRUE	Automatic
Range	Peak value to which the load cell was calibrated	FALSE	Automatic
Mass offset	Subtract this offset from the mass data <b>Default value is 0</b>	FALSE	User
Smoothing Algorithm	Algorithm used to smooth the mass data. <b>Default Value is Running Average</b>	FALSE	User
Smoothing Algorithm Value	Parameter for the smoothing algorithm <b>Default value is 11</b>	FALSE	User
MLR Algorithm	Algorithm used to calculate the mass loss rate (MLR) <b>Default is Linear Regression</b>	FALSE	User
MLR Algorithm Value	Parameter for the MLR algorithm. <b>Default value is 31</b>	FALSE	User
Initial	Mass measured at the start of the experiment	FALSE	Automatic
Final Value	Mass measured at the end of the experiment	FALSE	Automatic
Mass Loss	Total mass loss during experiment.	FALSE	Automatic
Mass Data	Mass data measured by the load cell	FALSE	Automatic
Mass Loss Rate Data	Mass loss rate data calculated from the mass data	FALSE	Automatic



ATF-LS-FRL-LI019 Weighing Devices	ID: 2137 Revision: 5
Authority: Technical Leader	Page: 11 of 13
Original maintained by Quality Programs; copies are uncontrolled.	

Parameter	Parameter Description	Required	Input Method
Average	Average mass loss rate for the entire experiment	FALSE	Automatic
Average 10-90	Average mass loss rate over the period where the 10 percent and 90 percent of the mass loss occurred	FALSE	Automatic
Corrected Mass Data	Mass data that has been corrected for the offset	FALSE	Automatic
Smoothed Mass Data	Mass data that has been corrected for the offset and smoothed	FALSE	Automatic
Time Out of Service	Indicates the elapsed test time that the instrument was removed from the test. All calculations for the data on the instrument cease at this time.	FALSE	User
Out of Service Reason	Specifies the reason that the instrument was removed from the experiment. Reasons typically include damage, impending damage, or test design	FALSE	User
Chart	Integer, Allows the user to group instrument data onto different charts. If this parameters is left empty all the charts will contain data for all instruments. A value of -1 indicates that the data will not be shown on a chart.	FALSE	User
Procedure for Out of Range Values Max	How to deal with data that went above the maximum allowable measurement reading.	FALSE	User
Procedure for Out of Range Values Min	How to deal with data that went below the minimum allowable measurement reading.	FALSE	User
Maximum Allowable measurement	The maximum measurement allowed to be used for the instrument	FALSE	Automatic
Minimum Allowable Measurement	The minimum measurement allowed to be used for the instrument	FALSE	Automatic
Readings Went out of Range	Indicates that the measurement went out of range.	FALSE	Automatic



ATF-LS-FRL-LI019 Weighing Devices	ID: 2137 Revision: 5
Authority: Technical Leader	Page: 12 of 13
Original maintained by Quality Programs; copies are uncontrolled.	

## **Appendix A – Definitions of Common Errors in Weighing Device Measurements**

Tolerance: The allowable difference between standard test loads and the measured load value calculated by the weighing device.

Readability: The readability of a weighing device is the smallest change in load which produces a signal that can be measured by the indicator. Readability is also referred to as the display resolution. Many error quantities are determined by the readability of the device.

Linearity: The deviation of the actual relationship between the load to signal output and a linear relationship throughout the entire capacity of the weighing device.

Hysteresis: The error associated with the direction and magnitude by which the load is applied. Hysteresis is calculated by applying loads ascending from zero to the rated output and then descending from the rated output to zero. The maximum difference obtained at each load step is considered the maximum hysteresis error.

Repeatability: The maximum difference between the load cell signal at repeated loads under identical loading and environmental conditions.

Creep: The change in signal output over time under constant load and environmental conditions.

Sensitivity: The sensitivity of the weighing device is equal to the smallest noticeable load applied to the device.

Temperature Effects: Errors associated with temperature change are more prevalent in weighing devices containing strain gauge load cells than MFR load cells due to their operating principles. Temperature can affect the material properties of the of the load cell, the electrical resistance of the strain gauge, and/or the bond of the strain gage to the beam.



ATF-LS-FRL-LI019 Weighing Devices	ID: 2137 Revision: 5
Authority: Technical Leader	Page: 13 of 13
Original maintained by Quality Programs; copies are uncontrolled.	

## References

---

1. Omega Engineering Inc. "Transactions in Measurement and Control: Force-Related Measurements (Vol. 3)." Stamford, CT, USA: Putman Publishing Company and Omega Press LLC, 1998.
2. NIST Weights and Measures Division. "Handbook 44: Specifications, Tolerances, and Other Technical Requirements for Weighing and Measuring Devices." Gaithersburg, MD: National Institute of Standards and Technology, 2010.
3. Taylor, B. N., & Kuyatt, C. E., "NIST Technical Note 1297: Guidelines for Evaluating and Expressing the Uncertainty of NIST Measurement Results." Gaithersburg, MD: National Institute of Standards and Technology, 1993.
4. Bryant, A.R., Ohlemiller, T.J., Johnsson, E.L, Hamins, A., Grove, B.S., Guthrie, W.F., Maranghides, A., Mulholland, G.W., "Special Publication 1007." Gaithersburg, MD: National Institute of Standards and Technology, 2003.
5. Guthrie, W. & Liu, H., "Hands-on Workshop on Estimating and Reporting Measurement Uncertainty." National Institute of Standards and Technology, Presentation given to CPSC, 2007.



ATF-LS-FRL-TR009a Differential Pressure - Point Velocity Probes	ID: 1592 Revision: 3
Authority: Technical Leader	Page: 1 of 10
Original maintained by Quality Programs; copies are uncontrolled.	

## Scope

This Technical Reference covers the use, design and specifications of Pitot-Static Probes and Bi-directional Probes used in the Bureau of Alcohol, Tobacco, Firearms and Explosives (ATF) Fire Research Laboratory (FRL).

## Instrument Description

### **GENERAL**

Pitot-static probes and bi-directional probes are used for point velocity calculations in a flow field based on measurements of the local differential pressure. They may be used for both internal and external flows. The probe designs are based on Bernoulli's principle which relates fluid velocity to the dynamic pressure. A typical configuration consists of the pressure probe inserted into a flow field with tubing connecting the probe to a differential pressure transducer. A thermocouple is placed near the probe location to monitor the local temperature. The thermocouple and pressure transducer are connected to the data acquisition system. All instrumentation must be calibrated according to the manufacturer and ATF specifications.

### **PITOT-STATIC PROBE**

Figure 1 shows a schematic of a typical Pitot-static probe [1]. The probe is designed to measure dynamic pressure directly. It has two pressure sensors: one on the tip that senses total, or stagnation, pressure; and one or more along the side that sense the static pressure. The difference between these is the dynamic pressure, which is measured using a differential pressure transducer.

Pitot-static probes are generally used in clean environments because the pressure ports are typically small and susceptible to blockage. Pitot-static probes are relatively insensitive to misalignment over a range of  $\pm 15^\circ$ , however can be used only for flow in one direction [1].



ATF-LS-FRL-TR009a Differential Pressure - Point Velocity Probes	ID: 1592 Revision: 3
Authority: Technical Leader	Page: 2 of 10
Original maintained by Quality Programs; copies are uncontrolled.	

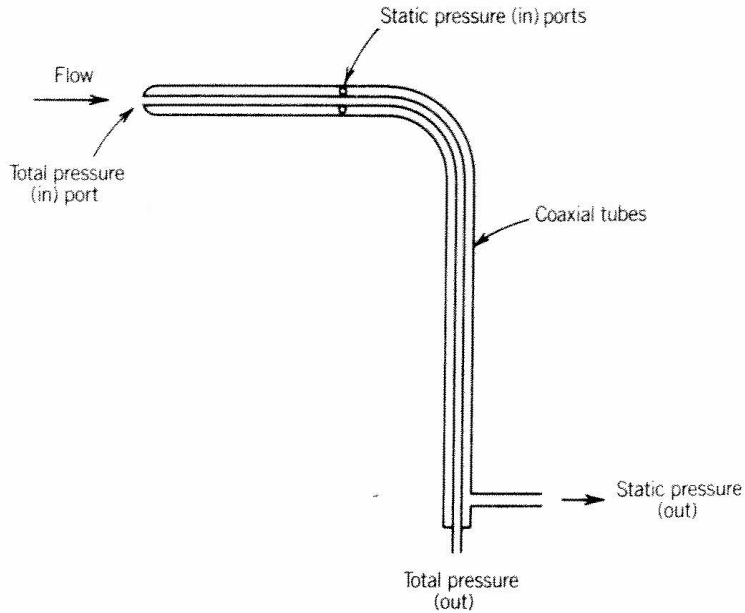

**Figure 1: Schematic of a Pitot-static probe [1]**

***BI-DIRECTIONAL PROBE***

A bi-directional probe is a device that contains two pressure ports facing opposite of each other to sense the static and total pressure of a point in the flow field. Figure 2 shows a schematic of a bi-directional probe. Bi-directional probes are frequently used in fire experiments because of their rugged design and their ability to sense pressure differentials in two directions. Additionally, bi-directional probes are relatively insensitive to alignment with the flow direction. Measured average velocities are accurate to within  $\pm 10\%$  with deviations as large as  $\pm 50^\circ$  between the probe axis and the flow direction [2].

While a Pitot-static probe measures dynamic pressure directly, a correction must be applied to bi-directional probe measurements in order to calculate velocity. This correction is discussed in the ‘Calculations’ section below.



ATF-LS-FRL-TR009a Differential Pressure - Point Velocity Probes	ID: 1592 Revision: 3
Authority: Technical Leader	Page: 3 of 10
Original maintained by Quality Programs; copies are uncontrolled.	

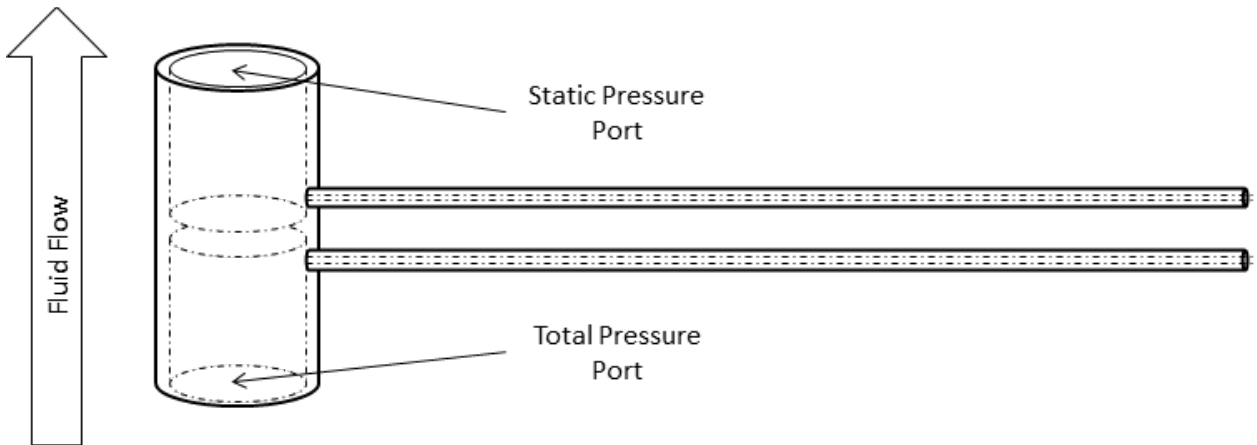

**Figure 2: Schematic of a bi-directional probe**

***TEMPERATURE MEASUREMENT***

In order to calculate velocity, temperature must be measured in addition to differential pressure. Typically this is accomplished by placing a thermocouple in the flow field, near the location of the probe. Figure 3 shows a photograph of a thermocouple mounted to a bi-directional probe. Further discussion on the use of thermocouples in the FRL can be found elsewhere [3].



**Figure 3: Shielded thermocouple mounted to a bi-directional probe**



ATF-LS-FRL-TR009a Differential Pressure - Point Velocity Probes	ID: 1592 Revision: 3
Authority: Technical Leader	Page: 4 of 10
Original maintained by Quality Programs; copies are uncontrolled.	

## ***PRESSURE TRANSDUCER***

Pitot-static probes and bi-directional probes are connected to differential pressure transducers using plastic or metal tubing. Velocities encountered in typical fire experiments correlate to small differential pressures, on the order of 0.62 kPa (2.5 inches of water) or less. The range of a selected transducer must be selected accordingly.

### MKS

The FRL uses MKS Type 220DD Baratron General Purpose Differential Pressure Manometers with a range of 0.13 kPa (0 – 1 Torr) [4]. Figure 4 shows a photograph of this instrument. The output of this device is 0 – 10 VDC.



**Figure 4: MKS Type 220DD Differential Pressure Manometer**

### Setra

The FRL uses Setra model 267 pressure transducers [5]. These instruments are available with a wide range of input and output settings. Figure 5 shows a photograph of this instrument.



ATF-LS-FRL-TR009a Differential Pressure - Point Velocity Probes	ID: 1592 Revision: 3
Authority: Technical Leader	Page: 5 of 10
Original maintained by Quality Programs; copies are uncontrolled.	



**Figure 5: Setra Model 267 Differential Pressure Transducer**

## Calculations

### VELOCITY CALCULATION

#### Pitot-Static Probe

The velocity is calculated according to the relation:

$$V = C\sqrt{\Delta PT} \quad (1.1)$$

where  $\Delta P$  is the measured differential pressure,  $T$  is the measured temperature at the velocity probe, and the flow factor  $C$  is calculated from  $\sqrt{2/\rho_0 T_0}$  where  $T_0$  is the reference temperature and  $\rho_0$  is the fluid density at the reference temperature [2].

#### Bi-Directional Probe

Eqn. (1.1) also applies to bi-directional probes, however the pressure difference is slightly greater than the dynamic pressure given in (1.1) and a correction to  $C$  is required. This correction varies with flow conditions and is well represented by a function of the Reynolds number ( $Re$ ) based on the probe diameter for  $40 < Re < 3800$  [2]:

$$\frac{\sqrt{\frac{2}{\rho_0 T_0}} \sqrt{\Delta PT}}{V} = 1.533 - 1.366 \cdot 10^{-3} Re + 1.688 \cdot 10^{-6} Re^2 - 9.706 \cdot 10^{-10} Re^3 + 2.555 \cdot 10^{-13} Re^4 - 2.484 \cdot 10^{-17} Re^5 \quad (1.2)$$



ATF-LS-FRL-TR009a Differential Pressure - Point Velocity Probes	ID: 1592 Revision: 3
Authority: Technical Leader	Page: 6 of 10
Original maintained by Quality Programs; copies are uncontrolled.	

Values of C for Pitot static and bidirectional probes are listed in Table 1 for a reference condition of  $T_0 = 300\text{K}$  and 1 atm ( $\rho_0 = 1.1774 \text{ kg/m}^3$ ) [6].

**Table 1 Flow factor (C in Eqn 1.1) for Pitot and Bidirectional probes**

Probe Type	Formula [2]	C Value at 300 K, 1 atm ( $\text{m}^{3/2}/\text{kg}^{1/2} \text{ K}^{1/2}$ ) [6]
Pitot-static	$\sqrt{2/\rho_0 T_0}$	0.075248
Bi-directional	$\sqrt{2/\rho_0 T_0} / f(\text{Re})$	0.075248 / f(Re)

Figure 6 shows a chart of Eqn. (1.2) plotted as a function of Reynolds number. Most flow conditions of interest in Fire Product Collectors (FPC) are characterized by Reynolds numbers higher than the upper limit of 3800 prescribed to Eqn. (1.2) in [2]. The Reynolds number for typical flows in FRL FPC's can range as high as 18,000 – 20,000. However, Eqn. (1.2) cannot be realistically extrapolated to Reynolds numbers higher than 3800. Because of this, a value of 1.08 is commonly applied to bidirectional probe FPC velocity measurements in place of a value calculated from Eqn. (1.2) [7]. The RHS of Eqn. (1.2) has a value of 1.081 at  $\text{Re} = 2000$ . For this reason, the approach adopted by the FRL is to apply Eqn (1.2) for  $40 < \text{Re} < 2000$  and use the constant 1.08 value for  $\text{Re} > 2000$ .



ATF-LS-FRL-TR009a Differential Pressure - Point Velocity Probes	ID: 1592 Revision: 3
Authority: Technical Leader	Page: 7 of 10
Original maintained by Quality Programs; copies are uncontrolled.	

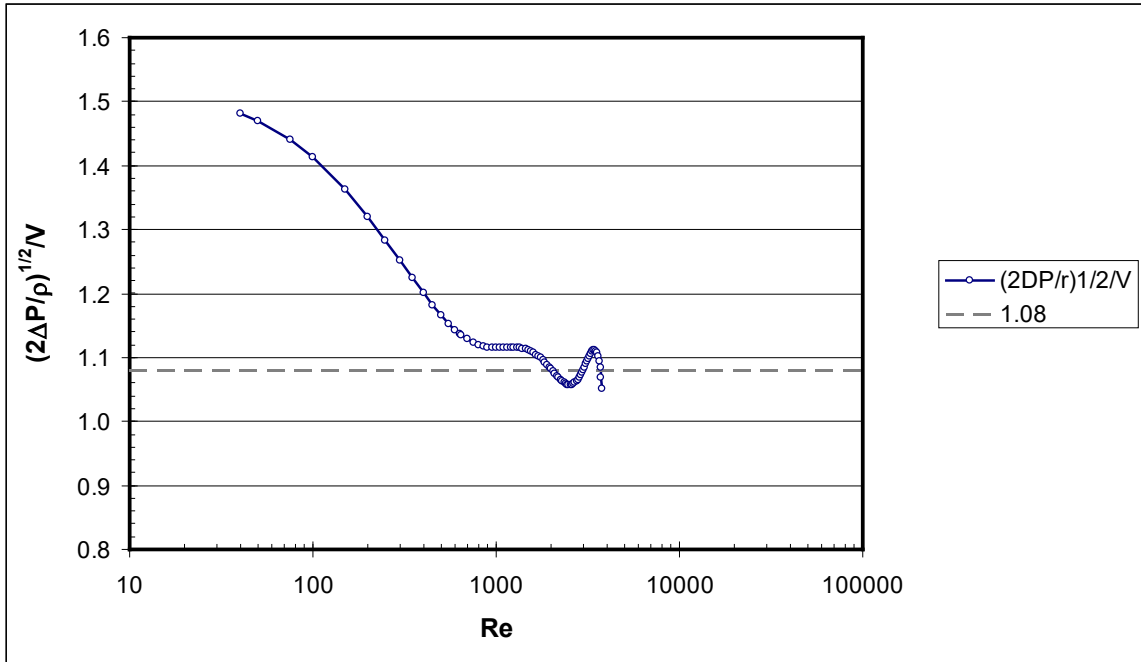

**Figure 6: Plot of Equation (1.2) showing bi-directional velocity correction factor as a function of Reynolds number.**

### **UNCERTAINTY CALCULATION**

The uncertainty of the FPC exhaust duct velocity measurements was estimated using the guidelines of the National Institute of Standards and Technology (NIST) Special Publication 1007 [7], Technical Note 1297 [8], and the NIST Uncertainty Workshop [9]. The combined standard uncertainty of the velocity is a combination of the uncertainty of its components given by the following equation:

$$u_c(V) = \sqrt{\sum s_i^2 u(x_i)^2} \quad (1.3)$$

where:

- $u_c(V)$  = Combined standard uncertainty of the velocity
- $u(x_i)$  = Standard uncertainty of each component
- $s_i$  = Sensitivity coefficient ( $\partial V / \partial x_i$ )

Using Eqn (1.1), the main sources of uncertainty are the differential pressure measurement, the temperature measurement, and the flow factor. Based on this, Eq. 1.3 can be applied to Eq. 1.1 to yield:

$$u_c(V) = \left[ (\sqrt{\Delta PT})^2 (u(C))^2 + \left( \frac{c}{2} \sqrt{\frac{T}{\Delta P}} \right)^2 (u(\Delta P))^2 + \left( \frac{c}{2} \sqrt{\frac{\Delta P}{T}} \right)^2 (u(T))^2 \right]^{1/2} \quad (1.4)$$



ATF-LS-FRL-TR009a Differential Pressure - Point Velocity Probes	ID: 1592 Revision: 3
Authority: Technical Leader	Page: 8 of 10
Original maintained by Quality Programs; copies are uncontrolled.	

where:

- $u(C)$  = Standard uncertainty of the flow factor C  
 $u(\Delta P)$  = Standard uncertainty of differential pressure measurement  
 $u(T)$  = Standard uncertainty of the temperature measurement

### Flow Factor

As shown in Table 1 the flow factor for a Pitot-static probe is a constant, based on the properties of air at the reference condition  $T = 300$  K and  $P = 1$  atm. The uncertainty of this value is taken as zero.

In the case of a bi-directional probe, the uncertainty stems from the error associated with the empirical fit of Eqn. (1.2). This error is taken as  $\pm 5\%$  [2].

### Differential Pressure

#### MKS 220DD

The MKS 220DD pressure transducer has a range of 0 to 0.13 kPa (0 - 1 Torr). MKS lists the accuracy as  $\pm 0.15\%$  of the reading. It can be assumed that the accuracy from the MKS 220DD has a rectangular probability distribution, in which case the standard uncertainty is calculated by dividing the accuracy by  $\sqrt{3}$  [8]. At the maximum pressure of 0.13 kPa, the accuracy of the MKS 220DD is  $\pm 0.2$  Pa. The corresponding standard uncertainty is  $\pm 0.12$  Pa.

The uncertainty of the differential pressure measurement also includes a statistical component based on random fluctuations in the measurements. The standard uncertainty of the random fluctuations is calculated using Eqn. (1.5),

$$u = \frac{s}{\sqrt{n}} \quad (1.5)$$

where:

- $S$  = Standard deviation of the measurements in a sample  
 $n$  = Number of measurements in the sample

The standard uncertainty for the MKS 220DD, based on a sample containing 600 measurements, is  $\pm 0.338$  Pa.

The standard uncertainties are combined in quadrature to calculate the combined standard uncertainty of the differential pressure readings. The result using the MKS 220DD is  $u(\Delta P) = 0.359$  Pa. This translates to a relative combined standard uncertainty of 0.269 %.



ATF-LS-FRL-TR009a Differential Pressure - Point Velocity Probes	ID: 1592 Revision: 3
Authority: Technical Leader	Page: 9 of 10
Original maintained by Quality Programs; copies are uncontrolled.	

### Setra 267

Setra lists the accuracy for a model 267 transducer as  $\pm 0.4\%$  F.S., the linearity as  $\pm 0.38\%$  F.S., the hysteresis as  $0.1\%$  F.S., and the repeatability as  $0.05\%$  F.S. [5]. It can be assumed that these each have a rectangular probability distribution, in which case the standard uncertainty is calculated by dividing each component by  $\sqrt{3}$  [8]. For a model with input range  $\Delta P = 0 - 0.62$  kPa ( $0 - 2.5$  inch H<sub>2</sub>O) the standard uncertainty of the differential pressure readings is  $\pm 2.04$  Pa.

The statistical component of the standard uncertainty, based on a sample containing 600 measurements, is  $\pm 0.453$  Pa.

The uncertainties are combined in quadrature to calculate the standard uncertainty of the differential pressure readings. The result for the Setra 267 is  $u(\Delta P) = 2.07$  Pa. This translates to a relative standard uncertainty of  $0.33\%$ .

### Temperature

The ATF FRL purchases Type-K thermocouples with a minimum accuracy of the greater of  $1.1^\circ\text{C}$  or  $0.4\%$  of the reading above  $0^\circ\text{C}$ . Temperature measurements in the FPC's are typically below  $275^\circ\text{C}$ , in which case the temperature accuracy is  $\pm 1.1^\circ\text{C}$ . It is assumed that the error from the thermocouple has a rectangular probability distribution, in which case the standard uncertainty is calculated by dividing the accuracy by  $\sqrt{3}$  [8]. The corresponding standard uncertainty for a temperature measurement is  $\pm 0.64^\circ\text{C}$ .

The standard uncertainty for the random fluctuations, based on a sample containing 600 measurements, is  $\pm 0.0021^\circ\text{C}$ .

The uncertainties are combined in quadrature to calculate the standard uncertainty of the temperature measurement. The result is  $u(T) = 0.64^\circ\text{C}$ .

### Summary

Table 2 summarizes the standard uncertainties of the velocity components as well as the combined standard uncertainty for velocity measurements for the conditions  $T = 275^\circ\text{C}$ ,  $\Delta P = 300$  Pa. Under these conditions, the nominal velocity (as measured using a bi-directional probe) is  $V = 28.3$  m/s.

**Table 2 Summary of uncertainty values for point pressure measurement setups**

Probe Type	Pressure Transducer	$u(C)$	$u(\Delta P)$ (Pa)	$u(T)$ ( $^\circ\text{C}$ )	$u_c(V)$ (m/s)	Relative Combined Standard Uncertainty (%)
Pitot-Static	MKS 220DD	0	0.359	0.64	0.0254	0.08
Pitot-Static	Setra 267	0	2.07	0.64	0.107	0.35
Bi-directional	MKS 220DD	$\pm 0.003$	0.359	0.64	1.35	4.76
Bi-directional	Setra 267	$\pm 0.003$	2.07	0.64	1.35	4.77



ATF-LS-FRL-TR009a Differential Pressure - Point Velocity Probes	ID: 1592 Revision: 3
Authority: Technical Leader	Page: 10 of 10
Original maintained by Quality Programs; copies are uncontrolled.	

## References

1. Figliola, R. S., and Beasley, D. E., *Theory and Design for Mechanical Measurements 2<sup>nd</sup> Edition*, John Wiley & Sons, New York, 1995.
2. McCaffrey, B. and Hekested, G., "A Robust Bidirectional Low-Velocity Probe for Flame and Fire Application," *Combustion and Flame*, Vol. 26, 1976, p.125 – p.127.
3. ATF FRL Instruction, "Laboratory Instruction LI001: Thermocouple."
4. "Type 220 Baratron General Purpose Differential Capacitance Manometer," MKS Technologies, Andover, MA, 2003.
5. "Installation Guide Model 267 and 267MR Differential Pressure Transducers," Setra, Boxborough, MA, 2002.
6. Holman, J. P., *Heat Transfer, 7<sup>th</sup> Edition*, McGraw-Hill, 1990.
7. Bryant, A.R., Ohlemiller, T.J., Johnsson, E.L, Hamins, A., Grove, B.S., Guthrie, W.F., Maranghides, A., Mulholland, G.W., "Special Publication 1007," National Institute of Standards and Technology, Gaithersburg, MD, 2003.
8. Taylor, B. N., & Kuyatt, C. E., "NIST Technical Note 1297: Guidelines for Evaluating and Expressing the Uncertainty of NIST Measurement Results," National Institute of Standards and Technology, Gaithersburg, MD, 1993.
9. Guthrie, W. & Liu, H., "Hands-on Workshop on Estimating and Reporting Measurement Uncertainty," National Institute of Standards and Technology, Presentation given to CPSC, 2007.



ATF-LS-FRL-TR009b Differential Pressure - Averaging Velocity Probes	ID: 1593 Revision: 3
Authority: Technical Leader	Page: 1 of 9
Original maintained by Quality Programs; copies are uncontrolled.	

## Scope

This Technical Reference covers the use, design and specifications of the Averaging Velocity Probes used in the Bureau of Alcohol, Tobacco, Firearms and Explosives (ATF) Fire Research Laboratory (FRL).

## Instrument Description

### **GENERAL**

Calculations related to large scale Fire Product Collectors (FPC) rely on knowledge of the flow rate of air and products of combustion through the exhaust duct. Because velocity profiles in the ducts are generally non-uniform, there are two approaches to measuring the flow rate. The first is to rely on point velocity measurements and the application of a flow shape factor. The second approach is to measure the average velocity directly. Instrumentation used for point velocity measurements are covered in a separate document [1]. Averaging velocity probes are used to measure the average dynamic pressure across a section of pipe or duct, from which the velocity is calculated without requiring a flow shape factor. Components consist of the probe itself, plus a mounting bracket to attach the probe to the duct. A typical configuration consists of two or more probes mounted inside a section of FPC duct with tubing connecting the probes to a differential pressure transducer. A thermocouple is placed near the probe location to monitor the local temperature. The thermocouple and pressure transducer are connected to the data acquisition system. All instrumentation must be calibrated according to the manufacturer and ATF specifications.

### Velocity Profiles

Flow in the FRL FPC exhaust ducts is turbulent, which generally causes velocity profiles to be flatter and more uniform. Additionally, each duct contains an orifice that is designed to enhance mixing. Despite this, velocity profiles in the FPC exhaust ducts are not uniform [2]. Figure 1 shows a chart of the velocity profile measured in the 14 MW FPC duct [2].



ATF-LS-FRL-TR009b Differential Pressure - Averaging Velocity Probes	ID: 1593 Revision: 3
Authority: Technical Leader	Page: 2 of 9
Original maintained by Quality Programs; copies are uncontrolled.	

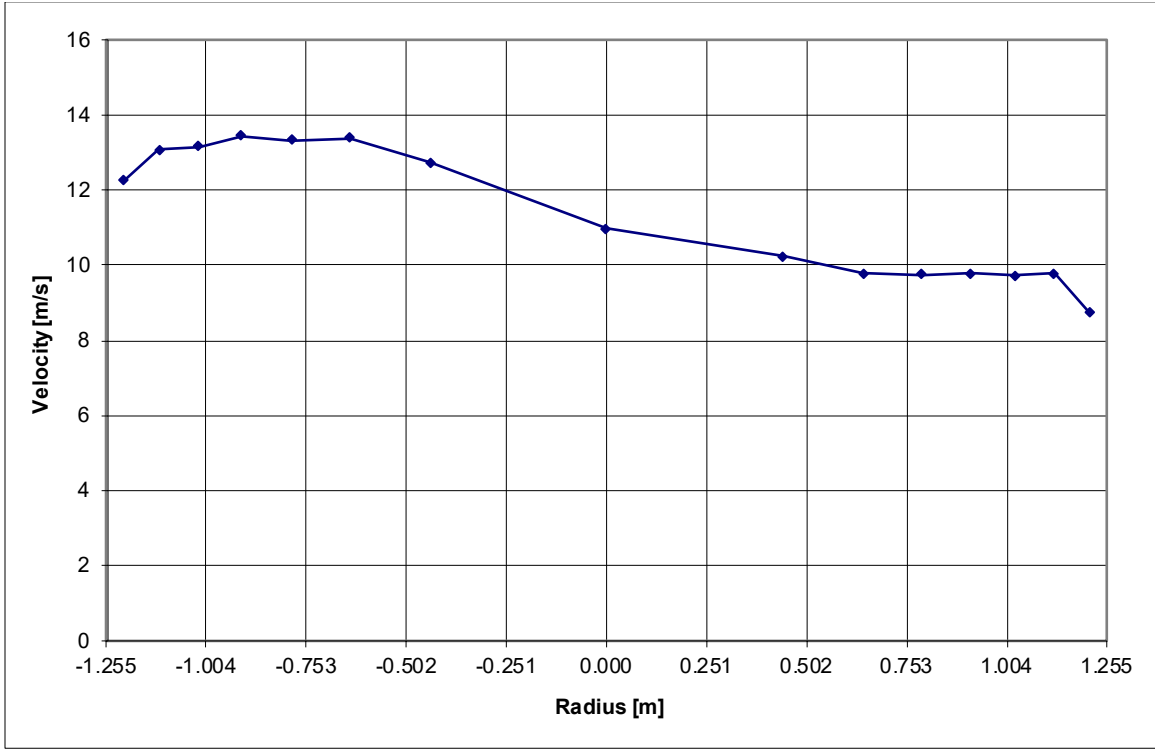

**Figure 1: Velocity profile measured in the 14 MW FPC duct.**

***PROBE DESCRIPTION***

Volu-Probe

The FRL uses externally mounted Volu-Probe Airflow Traverse Probes in the FPC exhaust ducts [3]. Figure 2 shows a schematic of the probe. The probe consists of two manifolds; one each for static and total pressure measurement. Each manifold has pressure ports spaced at equal area intervals as shown in Figure 3, producing a pressure representing the instantaneous average across the duct. Each manifold feeds to a 1.3 cm (0.5 inch) female NPT connection that is connected to a differential pressure transducer. The probes are mounted on one end with a 15.2 cm x 15.2 cm (6 inch x 6 inch) mounting plate, with the opposite end secured by a pin support. All components are constructed of stainless steel.



ATF-LS-FRL-TR009b Differential Pressure - Averaging Velocity Probes	ID: 1593 Revision: 3
Authority: Technical Leader	Page: 3 of 9
Original maintained by Quality Programs; copies are uncontrolled.	

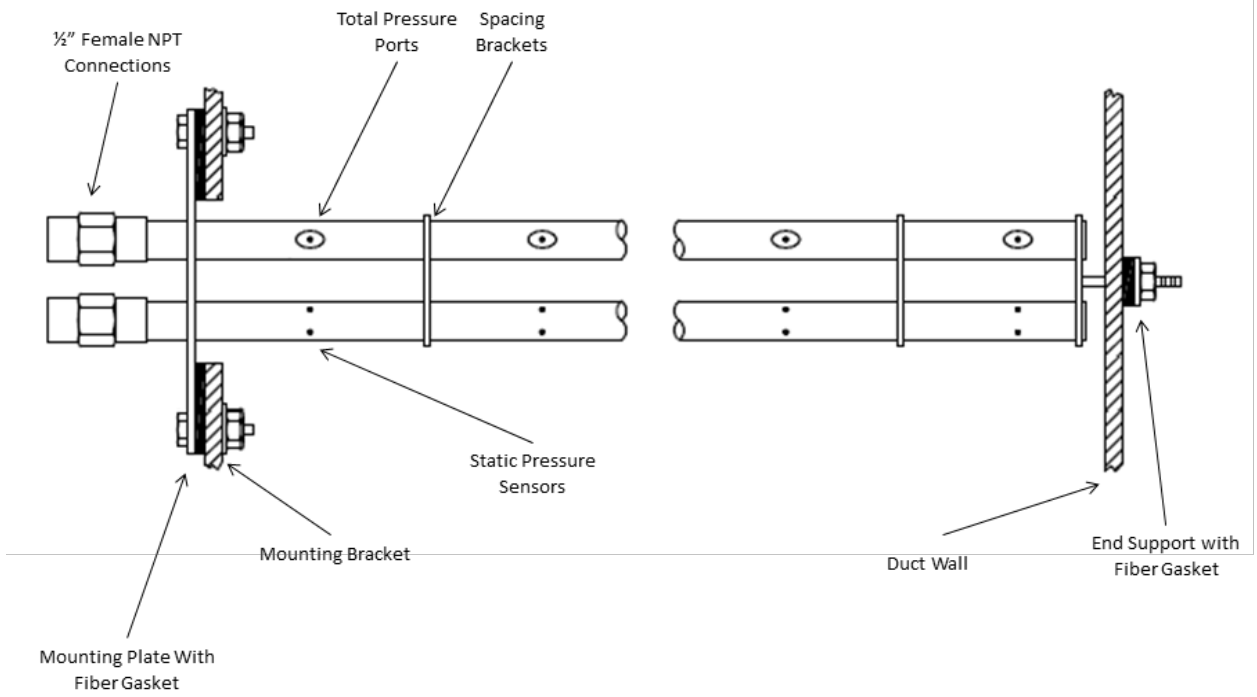

**Figure 2: Schematic of the velocity traverse probes [2].**



ATF-LS-FRL-TR009b Differential Pressure - Averaging Velocity Probes	ID: 1593 Revision: 3
Authority: Technical Leader	Page: 4 of 9
Original maintained by Quality Programs; copies are uncontrolled.	

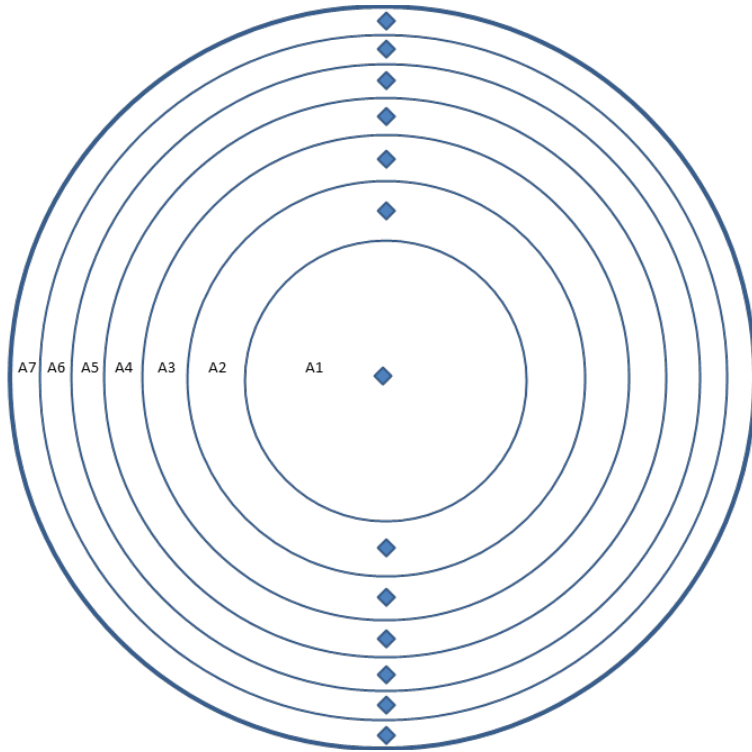

**Figure 3: The surface area of the duct divided into sections of equal area.**

Mounting Bracket

The probes are externally mounted to the duct using a 15.2 cm x 15.2 cm (6 inch x 6 inch) mounting bracket that is customized to fit the curvature of the exhaust duct (Figure 4). The mounting bracket is welded around a 10 cm (4 inch) hole in the exhaust duct. The probes are then inserted into the hole and the mounting plate is secured to the mounting bracket. High temperature fiber gasket is used to seal the space between the mounting plate and the mounting bracket as well as the duct wall at the end support.



ATF-LS-FRL-TR009b Differential Pressure - Averaging Velocity Probes	ID: 1593 Revision: 3
Authority: Technical Leader	Page: 5 of 9
Original maintained by Quality Programs; copies are uncontrolled.	

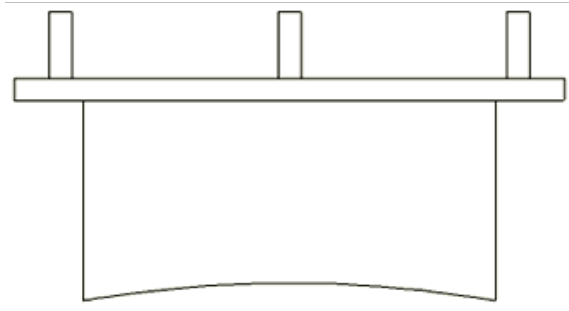

Side View

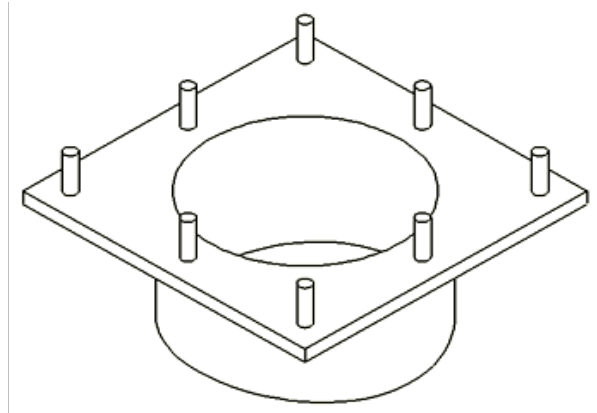

Isometric View

**Figure 4: The mounting bracket used to mount the probes to the exhaust duct.**

Probe Installation

The probes are installed in the exhaust duct based on manufacturer’s specifications [3]. Specifications require that multiple probes are used to achieve the stated accuracy of  $\pm 2 - 3 \%$ , with the number of probes depending on duct diameter. The probes are installed at an angle from each other with an axial spacing of 3.8 cm (1.5 inch) between the centers of the manifolds on each probe (Figure 5). The static and total pressure manifolds from each probe are combined into a single static pressure line and a single total pressure line via 1.3 cm (0.5 inch) tubing and Swagelok tee unions. The tubing is connected to a single differential pressure transducer.

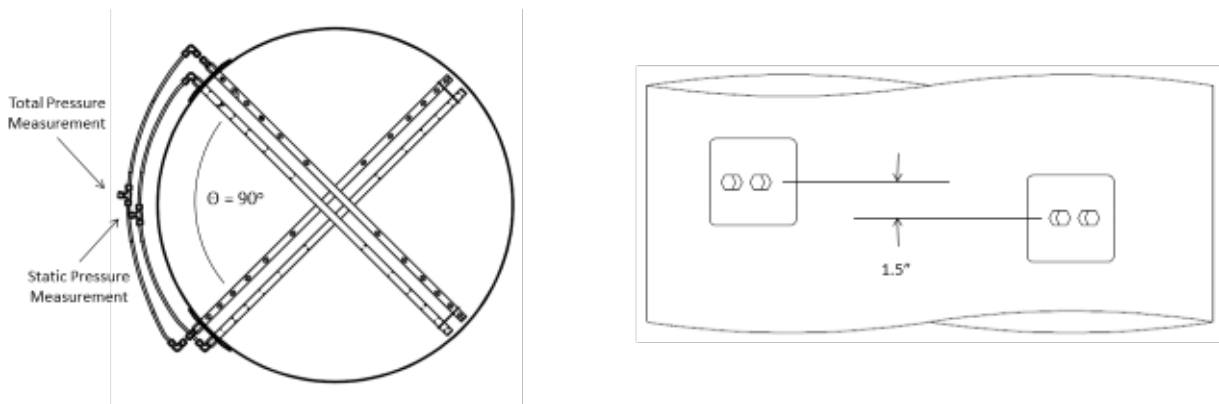

**Figure 5: The layout of the velocity traverse probes in the exhaust hoods for two probes [3].**



ATF-LS-FRL-TR009b Differential Pressure - Averaging Velocity Probes	ID: 1593 Revision: 3
Authority: Technical Leader	Page: 6 of 9
Original maintained by Quality Programs; copies are uncontrolled.	

## TEMPERATURE MEASUREMENT

In order to calculate velocity, temperature must be measured in addition to differential pressure. Typically this is accomplished by placing a thermocouple in the flow field, near the location of the probe. Further discussion on the use of thermocouples in the FRL can be found elsewhere [4].

## PRESSURE TRANSDUCER

### Setra

The FRL uses Setra model 267 pressure transducers for FPC measurements [5]. These instruments are available with a wide range of input and output settings. Generally, a transducer with a range of 0 – 622.7 Pa (0 – 2.5 inches of water) and an output of 4 – 20 mA works well in FPC applications. Figure 6 shows a photograph of this instrument.



Figure 6: Setra Model 267 Differential Pressure Transducer

## Calculations

### VELOCITY CALCULATION

The velocity is calculated according to the relation:

$$V = C\sqrt{\Delta PT} \quad (1.1)$$

where  $\Delta P$  is the measured differential pressure,  $T$  is the measured temperature at the velocity probe, and the flow factor  $C$  is calculated from  $\sqrt{2/\rho_0 T_0}$  where  $T_0$  is the reference temperature and  $\rho_0$  is the fluid density at the reference temperature [6].



ATF-LS-FRL-TR009b Differential Pressure - Averaging Velocity Probes	ID: 1593 Revision: 3
Authority: Technical Leader	Page: 7 of 9
Original maintained by Quality Programs; copies are uncontrolled.	

## UNCERTAINTY CALCULATION

The uncertainty of the FPC exhaust duct velocity measurements was estimated using the guidelines of the National Institute of Standards and Technology (NIST) Special Publication 1007 [7], Technical Note 1297 [8], and the NIST Uncertainty Workshop [9]. The combined standard uncertainty of the velocity is a combination of the uncertainty of its components given by the following equation:

$$u_c(V) = \sqrt{\sum s_i^2 u(x_i)^2} \quad (1.2)$$

where:

- $u_c(V)$  = Combined standard uncertainty of the velocity
- $u(x_i)$  = Standard uncertainty of each component
- $s_i$  = Sensitivity coefficient ( $\partial V / \partial x_i$ )

Using Eq. (1.1), the main sources of uncertainty in the velocity are the differential pressure and temperature measurements. Based on this, Eq. 1.1 can be applied to Eq. 1.2 to yield:

$$u_c(V) = \left[ (\sqrt{\Delta PT})^2 (u(C))^2 + \left( \frac{C}{2} \sqrt{\frac{T}{\Delta P}} \right)^2 (u(\Delta P))^2 + \left( \frac{C}{2} \sqrt{\frac{\Delta P}{T}} \right)^2 (u(T))^2 \right]^{1/2} \quad (1.3)$$

where:

- $u(C)$  = Standard uncertainty of the flow factor C
- $u(\Delta P)$  = Standard uncertainty of differential pressure measurement
- $u(T)$  = Standard uncertainty of the temperature measurement

### Flow Factor

The flow factor is a constant, based on the properties of air at the reference condition  $T = 300$  K and  $P = 1$  atm. The uncertainty of this value ( $u(C)$ ) is taken as zero.

### Differential Pressure

The uncertainty of the differential pressure measurement is comprised of two components. The first component is associated with the probe, and the second is associated with the pressure transducer. Errors associated with the data acquisition system are negligible.

### Probe Uncertainty

Volu-probe specifications indicate an accuracy of 2 – 3 %. For typical cold flow conditions in the 1 MW FPC ( $T = 300$  K,  $V = 17.3$  m/s,  $\dot{m} = 6.8$  kg/s), the average differential pressure is  $\Delta P = 175.3$  Pa.



ATF-LS-FRL-TR009b Differential Pressure - Averaging Velocity Probes	ID: 1593 Revision: 3
Authority: Technical Leader	Page: 8 of 9
Original maintained by Quality Programs; copies are uncontrolled.	

The corresponding error in the pressure measurement, assuming 3% accuracy, is 10.52 Pa. Assuming a square distribution, the standard uncertainty is  $u(\Delta P)_{probe} = \underline{6.07 \text{ Pa}}$  [8].

### Pressure Transducer

The Setra 267 pressure transducer has a range of 0 to 622.8 Pa (0 to 2.5 inches of water). Setra lists the accuracy as  $\pm 0.4\%$  F.S., the linearity as  $\pm 0.38\%$  F.S., the hysteresis as 0.1% F.S., and the repeatability as 0.05% F.S [4]. It can be assumed that the errors from the pressure transducer each have a rectangular probability distribution, in which case the standard uncertainty is calculated by dividing each component by  $\sqrt{3}$  [8]. Since these are all based on the full scale range of the transducer, they are independent of the measured value.

The uncertainty of the differential pressure measurement also includes variations arising from random fluctuations that occur naturally in the measurements. The standard uncertainty of the random fluctuations is calculated using equation 1.4,

$$u = \frac{S}{\sqrt{n}} \quad (1.4)$$

where:

S = Standard deviation of the measurements in a sample  
n = Number of measurements in the sample

The standard uncertainty for the pressure readings, based on a sample containing 600 measurements, is  $\pm 0.453 \text{ Pa}$ .

The standard uncertainties are combined in quadrature to calculate the combined standard uncertainty of the differential pressure readings. The result is  $u(\Delta P)_{transducer} = 2.07 \text{ Pa}$ .

The uncertainty associated with the probe and the pressure transducer are combined in quadrature to yield a combined standard uncertainty in the pressure measurement of  $\underline{u(\Delta P) = 6.42 \text{ Pa}}$ .

### Temperature

The temperature in the exhaust duct,  $T$ , is measured by a Type K thermocouple positioned at the center of the duct. The ATF FRL only purchases Type K thermocouples with a minimum accuracy of the greater of  $1.1^\circ\text{C}$  or 0.4% of the reading above  $0^\circ\text{C}$ . Assuming a reference temperature of  $25^\circ\text{C}$ , the error is  $\pm 1.1^\circ\text{C}$ . It is assumed that the error from the thermocouple has a rectangular probability distribution, in which case the standard uncertainty is calculated by dividing each component by  $\sqrt{3}$  [8]. The standard uncertainty for a temperature measurement at  $25^\circ\text{C}$  is therefore  $\pm 0.635^\circ\text{C}$ .

The standard uncertainty for the random fluctuations, based on a sample containing 600 measurements, is  $\pm 0.0021^\circ\text{C}$ .



ATF-LS-FRL-TR009b Differential Pressure - Averaging Velocity Probes	ID: 1593 Revision: 3
Authority: Technical Leader	Page: 9 of 9
Original maintained by Quality Programs; copies are uncontrolled.	

The standard uncertainties are combined in quadrature to calculate the combined standard uncertainty of the temperature readings. The result is  $u(T) = 0.635\text{ }^{\circ}\text{C}$ . This translates to a relative combined standard uncertainty of 2.54 %.

### Summary

Equation 1.2 is used to calculate the combined standard uncertainty in the velocity for the conditions  $\Delta P = 175.3\text{ Pa}$ ,  $T = 300\text{ K}$  and  $V = 17.3\text{ m/s}$ . The resulting uncertainty is  $u_c(V) = \pm 0.31\text{ m/s}$ .

### **References**

1. FRL Technical Reference, "TR009a – Differential Pressure – Point Velocity Probes."
2. "Fire Research Laboratory – Large Scale Calorimeter Velocity Traverses," ATF FRL, 2007.
3. "VOLU-Probe/SS Stainless Steel Pitot Airflow Traverse Probes" AMC Power, Santa Rosa, CA 2007.
4. ATF FRL Instruction, "Laboratory Instruction LI001 – Thermocouple."
5. "Installation Guide Model 267 and 267MR Differential Pressure Transducers," Setra, Boxborough, MA, 2002.
6. ATF FRL Instruction, "Laboratory Instruction LI009 – Velocity – Differential Pressure."
7. Bryant, A.R., Ohlemiller, T.J., Johnsson, E.L, Hamins, A., Grove, B.S., Guthrie, W.F., Maranghides, A., Mulholland, G.W., "Special Publication 1007," National Institute of Standards and Technology, Gaithersburg, MD, 2003.
8. Taylor, B. N., & Kuyatt, C. E., "NIST Technical Note 1297: Guidelines for Evaluating and Expressing the Uncertainty of NIST Measurement Results," National Institute of Standards and Technology, Gaithersburg, MD, 1993.
9. Guthrie, W. & Liu, H., "Hands-on Workshop on Estimating and Reporting Measurement Uncertainty," National Institute of Standards and Technology, Presentation given to CPSC, 2007.



ATF-LS-FRL-TR010A Sand Burners and Gas Carts	ID: 1567 Revision: 4
Authority: Technical Leader	Page: 1 of 16
Original maintained by Quality Programs; copies are uncontrolled.	

## Scope

This Technical Reference covers the use, design and specifications of sand burners and gas carts used in the Bureau of Alcohol, Tobacco, Firearms and Explosives (ATF) Fire Research Laboratory (FRL).

## Instrument Description

### GENERAL

Sand burners are used in experiments to produce fires of known size and configurations. They are generally used for calibration of oxygen consumption calorimeters, but can be used whenever a known, fire size is needed. Sand burner and gas cart setups consist of a gaseous fuel supply, a gas cart consisting of fuel flow monitoring instrumentation and fuel flow control, and a square sand burner as shown in Figure 1. All instrumentation must be calibrated according to manufacturer and ATF specifications.

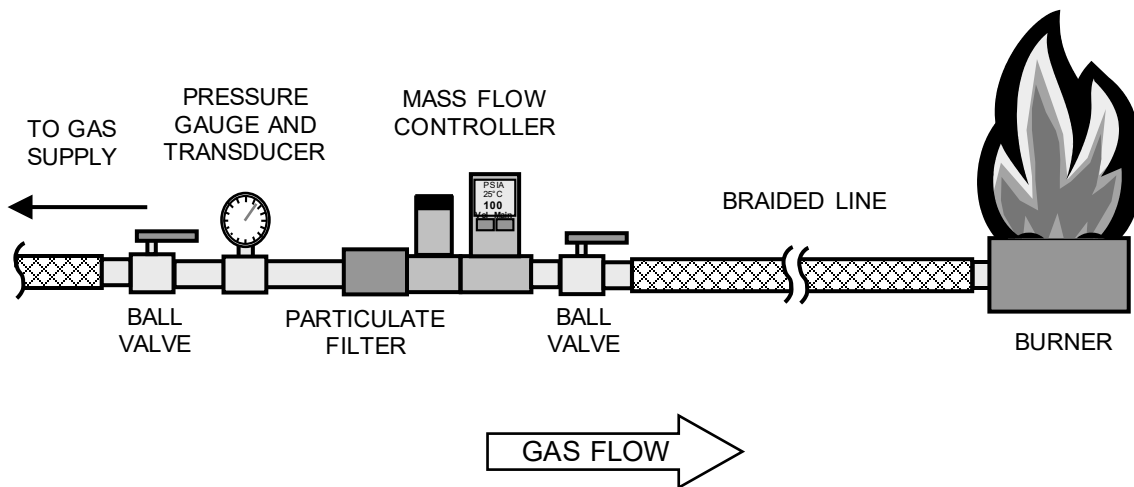

Figure 1. Sand burner and gas cart setup

### GAS CART DESCRIPTION

The gas carts used by the FRL consist of fuel flow monitoring and control instrumentation mounted on a mobile cart. The cart also contains data acquisition hardware.

Gas Carts A, B, C & D are McMaster model 4731T72 instrument cart. The cart has two shelves. The bottom shelf is enclosed and has a lockable door. The flow control and monitoring instrumentation is mounted on the top shelf. A gas cart is shown in Figure 2.



ATF-LS-FRL-TR010A Sand Burners and Gas Carts	ID: 1567 Revision: 4
Authority: Technical Leader	Page: 2 of 16
Original maintained by Quality Programs; copies are uncontrolled.	



**Figure 2. Gas Cart A**

Gas Cart E is a bi-level, mobile metal cart. The bottom shelf contains a sealable, waterproof box which houses the data acquisition components. The flow control and monitoring instrumentation is mounted on the top shelf. Gas Cart E is shown in Figure 3.

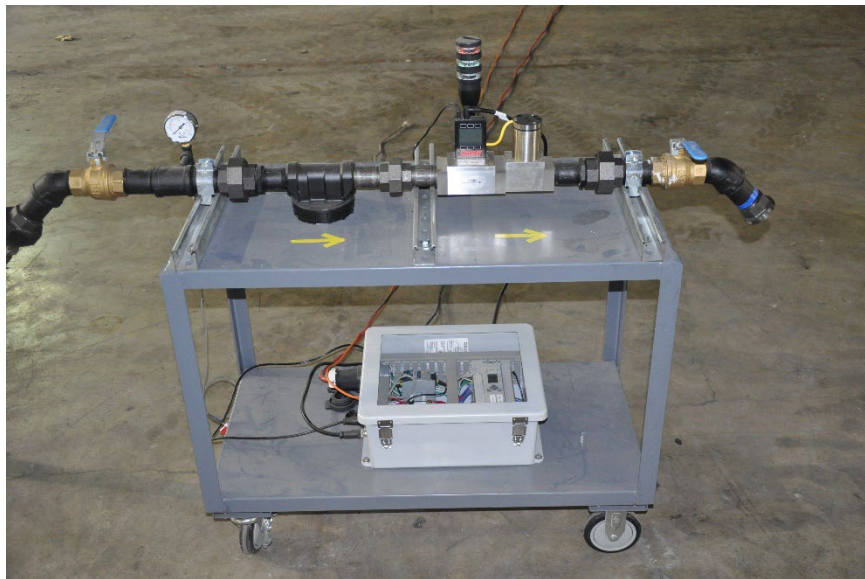

**Figure 3. Gas Cart E**

The flow control and monitoring instrumentation consists of components for pressure monitoring, flow control, and flow monitoring. Pressure monitoring is performed visually using a dial gauge and through data acquisition. A pressure gauge (0-206.8 kPa / 0-30 psig) is used to



ATF-LS-FRL-TR010A Sand Burners and Gas Carts	ID: 1567 Revision: 4
Authority: Technical Leader	Page: 3 of 16
Original maintained by Quality Programs; copies are uncontrolled.	

visually monitor the gas pressure in the train. A pressure transducer (Omegadyne PX209) transmits data to FireTOSS, but that data is only used for monitoring and is not used for calculations. For Gas Carts A, B, C, and D, flow control and monitoring is performed with an Alicat Scientific 16 Series Mass Flow Controller (MFC). For Gas Cart E, flow control and monitoring is performed with an Alicat Scientific MCR High-Flow Series MFC. A specified flow can be written to the MFC to control the fire size. The MFC also transmits an actual flow value to FireTOSS for monitoring and data acquisition purposes. A particulate filter (Arrow Pneumatics model 9076M for Carts A, B, C, and D; Parker Pneumatic model F602-10WJR/M4) is used in line upstream of the MFC. As shown in Table 1 FRL has five gas carts in operation: three with 1000 SLPM MFCs (Trains A, B, and D), one with a 100 SLPM MFC (Train C) and one with a 3000 SLPM MFC (Train E).

Gas Carts A, B, C, and D are connected to the natural gas main via 2.5 cm (1 inch) stainless steel braided hose (McMaster Carr Type 316), with 2.5 cm (1 inch) quick connect couplings to connect to the main and gas train. For the 1000 SLPM carts, the burner is connected to the cart using 2.5 cm (1 inch) stainless steel braided hose. For the 100 SLPM cart, the burner is connected to the cart using 0.64 cm (1/4 inch) stainless steel braided hose. Gas Cart E is connected to the gas main and to the burner via 5 cm (2 inch) stainless steel braided hose (McMaster Carr product number 5676T78).

**Table 1. Gas Cart Properties**

Gas Cart Type	Gas Train Name	HRR range (kW)
1000 SLPM Cart	A	0-575
1000 SLPM Cart	B	0-575
100 SLPM Cart	C	0-57.5
1000 SLPM Cart	D	0-575
3000 SLPM Cart	E	0-1320



ATF-LS-FRL-TR010A Sand Burners and Gas Carts	ID: 1567 Revision: 4
Authority: Technical Leader	Page: 4 of 16
Original maintained by Quality Programs; copies are uncontrolled.	

### **SAND BURNER DESCRIPTION**

The sand burners used in the ATF FRL are constructed in general accordance with the recommended ignition sources of ISO 9705 [1], ASTM E 1537 [2], and NFPA 286 [3]. Figure 3 shows a diagram of a typical sand burner. Natural gas is supplied to the sand burner via the gas inlet located at the base of the sand burner. As shown in Figure 3, the bottom of the sand burner contains a void space. A metal mesh is placed on a steel lip 7.5 cm (3 inch) from the bottom of the burner. The burner is then filled with a 2.5 cm (1 inch) layer of Fiberfrax, and 7.5 cm (3 inch) of small gravel. The Fiberfrax and gravel are used to diffuse the natural gas evenly across the entire opening of the burner.

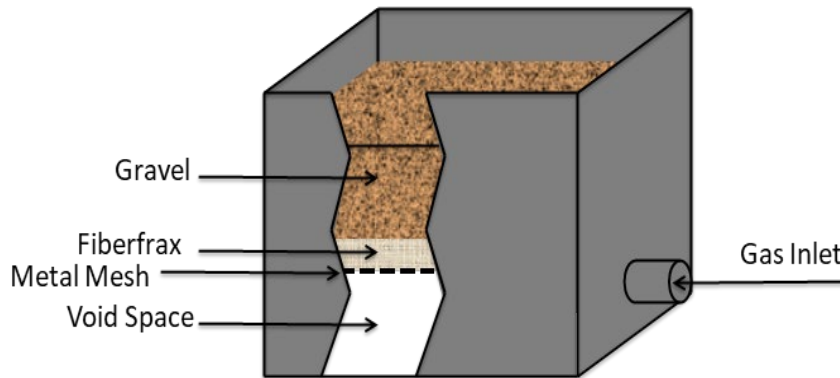

**Figure 4 – Diagram of a Typical Sand Burner**

There are three sizes of sand burners available for use in the FRL. The length and width of the burners are shown in Table 2. All sand burners available for use have the same height of 0.20 m.

**Table 2. Sand Burner Sizes**

Quantity Available	Sand Burner Size (m)
3	0.41 x 0.41
1	0.71 x 0.71
1	0.30 x 0.30
1	0.20 x 0.20



ATF-LS-FRL-TR010A Sand Burners and Gas Carts	ID: 1567 Revision: 4
Authority: Technical Leader	Page: 5 of 16
Original maintained by Quality Programs; copies are uncontrolled.	

## ***FUEL***

The primary type of fuel used in sand burners is natural gas, however other gaseous fuels may be used. Natural Gas is composed primarily of methane. See Appendix A for more information on the properties of natural gas.

## ***DATA ACQUISITION***

The instrumentation used on the gas carts is wired into an Allen Bradley Micrologix 1400 Programmable Logic Controller (PLC). Only the Analog I/O channels are used for data acquisition for the gas train. As seen in Figure 4, the PLC is located in an electrical box mounted inside of the enclosed lower shelf of the cart. A full list of channels assigned to instrumentation can be found in Appendix B. The PLC is an Ethernet based control module.



**Figure 5. Allen Bradley MicroLogix 1400 PLC inside Gas Cart**



ATF-LS-FRL-TR010A Sand Burners and Gas Carts	ID: 1567 Revision: 4
Authority: Technical Leader	Page: 6 of 16
Original maintained by Quality Programs; copies are uncontrolled.	

## **IGNITION SOURCE**

Ignition of the sand burners is achieved using a 6 mm (1/4 inch) diameter stainless steel “wand” fueled by a propane tank with a needle control valve, as seen in Figure 5.



**Figure 6. Propane “Wand” Ignition Source**

## **FireTOSS Calculations**

### **HEAT RELEASE RATE CALCULATION**

The heat release rate (HRR) of the fire is calculated using the flow rate of the fuel and the combustion properties of the fuel. Equation (1.1) expresses the HRR in terms of the mass flow rate of the fuel.

$$\dot{Q} = \eta \cdot \dot{m} \cdot \Delta H_{C,net} \quad (0.1)$$

Equation (1.2) expresses the HRR in terms of the volumetric flow rate of the fuel.

$$\dot{Q} = \eta \cdot \rho \cdot \dot{V} \cdot \Delta H_{C,net} \quad (0.2)$$

where

- $\dot{Q}$  = heat release rate of the burner (kW)
- $\eta$  = combustion efficiency of the fuel (assumed to be 1 for gaseous fuels).



ATF-LS-FRL-TR010A Sand Burners and Gas Carts	ID: 1567 Revision: 4
Authority: Technical Leader	Page: 7 of 16
Original maintained by Quality Programs; copies are uncontrolled.	

- $\dot{m}$  = mass flow rate of the fuel (kg/s)  
 $\Delta H_{C,net}$  = net heat of combustion of the fuel (kJ/kg)  
 $\rho$  = density of the fuel (kg/m<sup>3</sup>)  
 $\dot{V}$  = volumetric flow rate of the fuel (m<sup>3</sup>/s)

An example of heat release rate for natural gas calculated for a variety of flow rates is shown in Table 3.

**Table 3 - Heat Release Rate vs. Natural Gas Flow Rate**

HRR (kW)	Natural Gas Flow Rate (SLPM)
10	17.4
50	87.0
100	173.9
500	869.6
1000	1739.3
1500	2609
2000	3478.6
2500	4348.3
2800	4870

## Uncertainty and Accuracy

The uncertainty of the burners was estimated using the guidelines of the National Institute of Standards and Technology (NIST) Technical Note 1297 [4], Special Publication 1007 [5] and the NIST Uncertainty Workshop [6]. The combined standard uncertainty of the heat release rate is a combination of the uncertainty of its components, including flow, density and heat of combustion, among other factors, and is given by the following equation:

$$u_c(\dot{Q}) = \sqrt{\sum s_i^2 u(x_i)^2} \quad (0.3)$$

where:

- $u_c(\dot{Q})$  = Combined standard uncertainty of the burner heat release rate  
 $u(x_i)$  = Standard uncertainty of each heat release rate component  
 $s_i$  = Sensitivity coefficient ( $\partial y / \partial x_i$ )



ATF-LS-FRL-TR010A Sand Burners and Gas Carts	ID: 1567 Revision: 4
Authority: Technical Leader	Page: 8 of 16
Original maintained by Quality Programs; copies are uncontrolled.	

Using the volumetric formulation (Eq. 1.2), the main sources of uncertainty in the sand burner heat release rate are the volumetric flow rate (given by the mass flow controller), the density, and the heat of combustion, (both extracted from the combustion calorimeter, see Appendix A and [7]). Based on this, Eq. 1.3 can be applied to Eq. 1.2 to yield:

$$u_c(\dot{Q}) = \left[ \begin{aligned} &(\rho_{NG} \Delta H_{c,net})^2 (u(\dot{V}_{NG}))^2 + (\dot{V} \Delta H_{c,net})^2 (u(\rho_{NG}))^2 \\ &+ (\rho_{NG} \dot{V})^2 (u(\Delta H_{c,net}))^2 \end{aligned} \right]^{1/2} \quad (0.4)$$

where:

$u(\dot{V}_{NG})$  = Standard uncertainty of Natural Gas Volumetric Flow Rate

$u(\rho_{NG})$  = Standard uncertainty of Natural Gas Density

$u(\Delta H_{c,net})$  = Standard uncertainty of Natural Gas Heat of Combustion

Standard uncertainties for the natural gas density (0.015 kg/m<sup>3</sup>) and heat of combustion (1.05 MJ/kg) were computed based on an evaluation of the combustion calorimeter [7].

The uncertainty of the volumetric flow rate is evaluated by considering the operation of the MFC and the makeup of natural gas. The MFC reading is based on the pressure drop of a gas as it passes through a laminar flow element. The flow rate is based on the viscosity of the flowing gas. If the gas being used is not what has been selected on the controller a conversion factor must be used. The conversion has the form [8]:

$$\dot{V}_2 = \dot{V}_1 \left( \frac{\eta_1}{\eta_2} \right) \quad (0.5)$$

where:

$\dot{V}_2$  = Volumetric flow rate of gas in use (SLPM)

$\dot{V}_1$  = Flow reading produced by the MFC (SLPM)

$\eta_2$  = Viscosity of gas in use

$\eta_1$  = Viscosity of gas for which MFC is set

Since natural gas is a blend of species with methane having the largest concentration, the MFC is set up using the properties of methane ( $\eta_1$ ). The flow rate of natural gas ( $\dot{V}_2$ ) is proportional to the flow reported by the mass flow controller ( $\dot{V}_1$ ) based on Eq. 1.5:

$$\dot{V}_{NG} = \dot{V}_{CH_4} \left( \eta_{CH_4} / \eta_{NG} \right)$$

where

$\dot{V}_{NG}$  = Flow rate of natural gas (SLPM)



ATF-LS-FRL-TR010A Sand Burners and Gas Carts	ID: 1567 Revision: 4
Authority: Technical Leader	Page: 9 of 16
Original maintained by Quality Programs; copies are uncontrolled.	

$\dot{V}_{CH_4}$  = Flow rate of methane as measured by the MFC (SLPM)

$\eta_{CH_4}$  = Viscosity of methane at 25°C;  $\eta_{CH_4} = 111.296 \mu$  Poise [8]

$\eta_{NG}$  = Viscosity of natural gas at 25°C in  $\mu$ Poise

The uncertainty in the natural gas flow rate ( $\dot{V}_{NG}$ ) can be calculated by applying Eq. 1.3 to the expression above. Treating the viscosity ratio as a single term yields:

$$u(\dot{V}_{NG}) = \sqrt{\left(\frac{\eta_{CH_4}}{\eta_{NG}}\right)^2 (u(\dot{V}_{CH_4}))^2 + (\dot{V}_{CH_4})^2 \left(u\left(\frac{\eta_{CH_4}}{\eta_{NG}}\right)\right)^2} \quad (0.6)$$

The uncertainty in the methane flow rate ( $\dot{V}_{CH_4}$ ) can be divided into two components. The first component is the accuracy and repeatability of the MFC. The second component is the random fluctuations that occur in the flow measurement.

Alicat Scientific lists the MFC accuracy as  $\pm$  (0.8% of full scale + 0.2% of the reading) and the repeatability as  $\pm$  0.2 % of full scale [8]. It can be assumed that these errors have a rectangular probability distribution, in which case the standard uncertainty is computed by dividing each component by  $\sqrt{3}$  [4]. The error associated with accuracy in the mass flow controller increases as the flow increases; therefore, a high flow will yield the highest (absolute) uncertainty. The accuracy is calculated at 100 % capacity (1000 SLPM) as:

$$(0.008 \times 1000 \text{ SLPM}) + (0.002 \times 1000 \text{ SLPM}) = \pm 10 \text{ SLPM}$$

The corresponding standard uncertainty is 5.8 SLPM. Similarly, the repeatability is calculated as:

$$(0.002 \times 1000 \text{ SLPM}) = \pm 2 \text{ SLPM}$$

The corresponding standard uncertainty is 1.2 SLPM.

The contribution to the uncertainty based on random fluctuations in the measurement is evaluated using a statistical analysis. The standard uncertainty is calculated as:

$$u = \frac{S}{\sqrt{n}} \quad (0.7)$$

where:

S = Sample standard deviation



ATF-LS-FRL-TR010A Sand Burners and Gas Carts	ID: 1567 Revision: 4
Authority: Technical Leader	Page: 10 of 16
Original maintained by Quality Programs; copies are uncontrolled.	

n = Number of measurements used in the evaluation of S

The standard uncertainty at maximum flow, based on a sample of 236 data points, is 0.22 SLPM.

The standard uncertainties are combined in quadrature to calculate the combined standard uncertainty of the methane flow rate. The result is  $u(\dot{V}_{\text{CH}_4}) = \underline{5.9 \text{ SLPM}}$ .

In order to calculate the uncertainty in the natural gas flow rate, the uncertainty associated with the natural gas viscosity must be estimated. However, it is difficult to obtain an accurate viscosity of a gas mixture with over 10 components such as natural gas. The NIST predictive model SUPERTRAPP [9] was used to determine the viscosity of natural gas based on average gas concentrations provided by Washington Gas (see Table 4). According to the SUPERTRAPP developer, Marcia Huber of NIST, the accuracy of the model for natural gas is about 2% [10]. The SUPERTRAPP model provides a natural gas viscosity prediction of 113.25  $\mu\text{Poise}$  at 25°C and 14.695 psia, which is only 1.8% different from the viscosity of pure methane. However the SUPERTRAPP model predicts the viscosity of pure methane to be 113.42  $\mu\text{Poise}$ , which is 1.9% different from the actual viscosity of pure methane, but only 0.2 % different from the natural gas viscosity prediction. This indicates that the viscosity of natural gas is very close to that of pure methane.

Based on work performed by Neil Hartman of Alicat Scientific, the viscosity of natural gas was calculated using the semi-empirical formula of Wilke [11]. Hartman, found that the actual difference between the viscosity of natural gas as compared to pure methane is less than 0.6% [12].

Based on this, the combined standard uncertainty in the natural gas flow rate is calculated to be  $u(\dot{V}_{\text{NG}}) = \underline{8.4 \text{ SLPM}}$ .



ATF-LS-FRL-TR010A Sand Burners and Gas Carts	ID: 1567 Revision: 4
Authority: Technical Leader	Page: 11 of 16
Original maintained by Quality Programs; copies are uncontrolled.	

**Table 4 - Average Natural Gas Concentrations (Dry) – Determined from data provided by Washington Gas for 88 days from December 15, 2004 – March 30, 2005.**

	<b>Average Concentration (%)</b>	<b>Standard Deviation (%)</b>	<b>± Error</b>	<b>Percent Error</b>
Methane	94.116	0.363	0.73	0.77
Ethane	3.386	0.343	0.69	20.25
Propane	0.650	0.063	0.13	19.50
i-Butane	0.092	0.007	0.01	16.28
n-Butane	0.127	0.013	0.03	20.90
Neopentane	0.001	0.0003	0.001	57.74
i-Pentane	0.042	0.004	0.01	17.04
n-Pentane	0.031	0.003	0.01	17.18
Nitrogen	0.632	0.089	0.18	28.31
CO <sub>2</sub>	0.848	0.049	0.10	11.49
C6+ 47/35/17	0.074	0.006	0.01	15.47
Water	0.000	N/A	N/A	N/A

Using the standard uncertainties of the natural gas flow rate, density and heat of combustion, the combined standard uncertainty in the heat release rate of the burner can be determined by Equation (1.4) (repeated below for convenience):

$$u_c(\dot{Q}) = \underline{17.8 \text{ kW}}$$

This translates to a relative combined standard uncertainty of 3.1 % at a flow of 1000 SLPM.



ATF-LS-FRL-TR010A Sand Burners and Gas Carts	ID: 1567 Revision: 4
Authority: Technical Leader	Page: 12 of 16
Original maintained by Quality Programs; copies are uncontrolled.	

## Appendix A – Calculation of Natural Gas Properties

In order to calculate the heat release rate of the burner using Equation (1.1), the properties of the gas are needed. The most typical fuel gas that will be used by the FRL to fuel the burners is natural gas. Natural gas is a mixture of gases whose major components are methane, propane, i-butane, n-butane, neopentane, i-pentane, n-pentane, nitrogen, carbon dioxide, ethane and heavier hydrocarbons with six or more carbon atoms (referred to by Washington Gas as “C6+ 47/35/17”). These component concentrations vary over time, thus varying the properties of the natural gas. Therefore, the properties of natural gas supplied to the FRL were calculated using a combustion calorimeter which measured the calorific value and specific gravity of the natural gas [7].

### Combustion Calorimeter

A Union CWD 2000 Combustion Calorimeter was used to determine the calorific value and specific gravity of the natural gas supply [13]. The caloric value was measured over a range of 35000-45000 kJ/m<sup>3</sup> and the specific gravity was measured over a range of 0.2-2.2, with respect to air. Both of these values are output as a 4-20 mA current. The calorimeter is automatically calibrated every weekday.

### Density

The density ( $\rho$ ) of natural gas is calculated based on the specific gravity of the gas and the relationship of natural gas density to air density:

$$\rho_{NG} = \rho_{Air} * SG_{NG} \quad (0.8)$$

where

$\rho_{NG}$  = density of natural gas in kg/m<sup>3</sup>

$\rho_{Air}$  = density of air in kg/m<sup>3</sup>

$SG_{NG}$  = specific gravity of natural gas in relation to air

Substituting Equation 1.8 into the ideal gas law yields:

$$\rho_{NG} = \frac{SG_{NG} * P}{R * T} \quad (0.9)$$

where

$P$  = Pressure (Pa)

$R$  = Gas Constant for Air, 287 J/kg•K

$T$  = Temperature (K)

The density of the natural gas is calculated as a static value for sand burners. The specific gravity is the average of a two minute baseline reading taken prior to the start of the test. The values used for pressure and temperature are at STP to coincide with the output of the mass flow controller.



ATF-LS-FRL-TR010A Sand Burners and Gas Carts	ID: 1567 Revision: 4
Authority: Technical Leader	Page: 13 of 16
Original maintained by Quality Programs; copies are uncontrolled.	

### Net heat of combustion

The calorific (heating) value of natural gas is determined by the combustion calorimeter and output in  $\text{kJ/m}^3$ . However, the gas property necessary for the burner calculations in Equation (1.1) is the net heat of combustion ( $\Delta H_{C,net}$ ) in units of  $\text{kJ/kg}$ . The gross heat of combustion of natural gas was calculated based on the heating value and the density of natural gas:

$$\Delta H_{C,gross} = \frac{C.V.}{\rho_{NG}} \quad (0.10)$$

where

$\Delta H_{C,gross}$  = gross heat of combustion of the gas mixture in  $\text{kJ/kg}$

$C.V.$  = calorific value of natural gas in  $\text{kJ/m}^3$

$\rho_{NG}$  = density of natural gas in  $\text{kg/m}^3$

This calculation yields a value in terms of the higher heating value, which does not account for water vapor. To account for water vapor, a correlation from Bossel [14] was used to convert to the lower heating value.

$$\Delta H_{C,net} = \Delta H_{C,gross} * 0.896 \quad (0.11)$$

The heat of combustion of the natural gas is calculated as a static value for sand burners. The calorific value is the average of a two minute baseline reading taken prior to the start of the test. The natural gas density is the average density calculated during the same two minute baseline.



ATF-LS-FRL-TR010A Sand Burners and Gas Carts	ID: 1567 Revision: 4
Authority: Technical Leader	Page: 14 of 16
Original maintained by Quality Programs; copies are uncontrolled.	

## Appendix B – Data Acquisition Channel Assignments

### *Train A*

Channel	FireTOSS Channel Name	Instrument
Analog Input 1	ML135_AI_01	MFC Read Value
Analog Input 2	ML135_AI_02	Pressure Transducer
Analog Input 3	ML135_AI_03	Unassigned
Analog Input 4	ML135_AI_04	Unassigned
Analog Output 1	ML135_AO_01	MFC Write Value
Analog Output 2	ML135_AO_02	Unassigned

### *Train B*

Channel	FireTOSS Channel Name	Instrument
Analog Input 1	ML136_AI_01	MFC Read Value
Analog Input 2	ML136_AI_02	Pressure Transducer
Analog Input 3	ML136_AI_03	Unassigned
Analog Input 4	ML136_AI_04	Unassigned
Analog Output 1	ML136_AO_01	MFC Write Value
Analog Output 2	ML136_AO_02	Unassigned

### *Train C*

Channel	FireTOSS Channel Name	Instrument
Analog Input 1	ML133_AI_01	MFC Read Value
Analog Input 2	ML133_AI_02	Pressure Transducer
Analog Input 3	ML133_AI_03	Unassigned
Analog Input 4	ML133_AI_04	Unassigned
Analog Output 1	ML133_AO_01	MFC Write Value
Analog Output 2	ML133_AO_02	Unassigned

### *Train D*

Channel	FireTOSS Channel Name	Instrument
Analog Input 1	ML178_AI_01	MFC Read Value
Analog Input 2	ML178_AI_02	Pressure Transducer
Analog Input 3	ML178_AI_03	Unassigned
Analog Input 4	ML178_AI_04	Unassigned
Analog Output 1	ML178_AO_01	MFC Write Value
Analog Output 2	ML178_AO_02	Unassigned



ATF-LS-FRL-TR010A Sand Burners and Gas Carts	ID: 1567 Revision: 4
Authority: Technical Leader	Page: 15 of 16
Original maintained by Quality Programs; copies are uncontrolled.	

### ***Train E***

<b>Channel</b>	<b>FireTOSS Channel Name</b>	<b>Instrument</b>
Analog Input 1	ML134_AI00_00	MFC Read Value
Analog Input 2	ML134_AI00_01	Pressure Transducer
Analog Input 3	ML134_AI00_02	Unassigned
Analog Input 4	ML134_AI00_03	Unassigned
Analog Output 1	ML134_AO00_00	MFC Write Value
Analog Output 2	ML134_AO_01	Unassigned



ATF-LS-FRL-TR010A Sand Burners and Gas Carts	ID: 1567 Revision: 4
Authority: Technical Leader	Page: 16 of 16
Original maintained by Quality Programs; copies are uncontrolled.	

## References

1. International Organization for Standardization, "ISO9705: Fire Tests – Full Scale Room Test for Surface Products," ISO, Geneva, Switzerland, 1993.
2. American Society for Testing and Materials, "ASTM E1537: Standard Test Method for Fire Testing of Upholstered Furniture," ASTM, West Conshohocken, PA, 2002.
3. National Fire Protection Association, "NFPA286: Standard Methods of Fire Tests for Evaluating Contribution of Wall and Ceiling Interior Finish to Room Fire Growth," NFPA, Quincy, MA, 2000.
4. Taylor, B. N., & Kuyatt, C. E., "NIST Technical Note 1297: Guidelines for Evaluating and Expressing the Uncertainty of NIST Measurement Results," National Institute of Standards and Technology, Gaithersburg, MD, 1993.
5. Bryant, A.R., Ohlemiller, T.J., Johnsson, E.L, Hamins, A., Grove, B.S., Guthrie, W.F., Maranghides, A., Mulholland, G.W., "Special Publication 1007," National Institute of Standards and Technology, Gaithersburg, MD, 2003.
6. Guthrie, W. & Liu, H., "Hands-on Workshop on Estimating and Reporting Measurement Uncertainty," National Institute of Standards and Technology, Presentation given to CPSC, 2007.
7. ATF FRL Instruction, "Laboratory Instruction LI00018: Combustion Calorimeter."
8. "16 Series Mass and Volumetric Flow Controllers, Operating Manual," Alicat Scientific, Tucson, Arizona.
9. NIST Thermophysical Properties of Hydrocarbon Mixtures Database (SUPERTRAPP), Version 3.1, National Institute of Standards and Technology, Gaithersburg, MD, 2003.
10. E-mail correspondence with Marcia Huber of NIST, dated December 28, 2004.
11. C. R. Wilke, J. Chem. Phys., 517 (1950).
12. Hartman, Neil, Unpublished natural gas viscosity calculations.
13. "Users Manual – CWD 2000 Combustion Calorimeter – For high speed measurement of fuel gases" Union, 2007.
14. Bossel, U., "Well-to-Wheel Studies, Heating Values, and the Energy Conservation Principle," Oberrohrdorf, Switzerland, 2003. <http://www.efcf.com/reports/E10.pdf>



ATF-LS-FRL-TR010B Tube Burner	ID: 1568 Revision: 4
Authority: Technical Leader	Page: 1 of 20
Original maintained by Quality Programs; copies are uncontrolled.	

## Scope

This Technical Reference covers the use, design, and specifications of the tube burner used in experiments conducted at the Bureau of Alcohol, Tobacco, Firearms and Explosives (ATF) Fire Research Laboratory (FRL).

## Instrument Description

### *GENERAL*

The tube burner is used in experiments to produce fires of known size and configurations. It is generally used for calibration of oxygen consumption calorimeters, but can be used whenever a known fire size is needed. The tube burner setup consists of a natural gas fuel supply, a gas train consisting of fuel flow monitoring instrumentation and fuel flow control, and the tube burner itself. All instrumentation must be calibrated according to manufacturer and ATF specifications.

### *GAS TRAIN AND FLOW CONTROL/MONITORING DESCRIPTION*

The tube burner uses a gas train located in the Mezzanine of the FRL, shown in Figure 1 This gas train contains the primary fuel supply valve, the flow control and flow monitoring devices, and the emergency shut off valve for the tube burner. All control and monitoring are achieved within this gas train. The burner assembly is fitted with solenoid valves capable of opening and closing flow to any of the four sets of burner banks. \\* MERGEFORMAT



**Figure 1 - Gas Train in Mezzanine**



ATF-LS-FRL-TR010B Tube Burner	ID: 1568 Revision: 4
Authority: Technical Leader	Page: 2 of 20
Original maintained by Quality Programs; copies are uncontrolled.	

### Shutoff Valve

A manually operated shutoff valve is located at the inlet of the mezzanine gas train and is shown in Figure 2. This valve is operated by rotating the valve handle clockwise to open the valve and counterclockwise to close the valve. This valve is kept closed at all times prior to and after testing to prevent leakage of gas into the laboratory or plenum space.



**Figure 2 –Manual Shutoff Valve for Mezzanine Gas Train**

### Type 99 Pressure Reducing Regulator

The natural gas supply pressure is regulated through a pressure regulator, shown in Figure 3 \\* MERGEFORMAT . The incoming pressure is reduced down to approximately 200 kPa (29 psia). Fluctuations in the inlet pressure are reduced through this regulator and a steady pressure is maintained downstream. This device utilizes a yoked double-diaphragm pilot to mechanically control the output pressure. It does not contain any electrical parts and does not communicate with the DAQ.



ATF-LS-FRL-TR010B Tube Burner	ID: 1568 Revision: 4
Authority: Technical Leader	Page: 3 of 20
Original maintained by Quality Programs; copies are uncontrolled.	



**Figure 3 – Type 99 Pressure Reducing Regulator**

Maxon Valve Emergency Shutoff

The Maxon valve, shown in Figure 4 \\* MERGEFORMAT , is a normally closed valve placed in the main flow line. The valve is connected to four separate shutoff switches located in each burn room in the laboratory (two each in the MBR and LBR). If any of the four switches are pressed this valve is closed, stopping the flow of gas through the gas train. There is, however, a significant amount of pipe between the burner and the shutoff valve, and thus additional safety measures have been implemented to prevent a release of gas.



**Figure 4 – Maxon Emergency Shutoff Valve**



ATF-LS-FRL-TR010B Tube Burner	ID: 1568 Revision: 4
Authority: Technical Leader	Page: 4 of 20
Original maintained by Quality Programs; copies are uncontrolled.	

### Instromet IRM-A Rotary Gas Meter

The rotary gas meter, shown in Figure 5 \\* MERGEFORMAT , is designed to measure the volume of gas flow in the line. Measurements are made through the use of counter rotating figure-eight rotors in a chamber of constant volume. Each revolution displaces a fixed volume of gas in four strokes. Each revolution is timed, producing a frequency output that is directly proportional to the volume flow rate. The volume flow rate is independent of any properties of the gas, including pressure, density, and viscosity.

Gas pressure and temperature are monitored inside the flow meter through the use of a pressure transducer and thermocouple, respectively. The output signal from the flow meter is converted from frequency to amperage using a frequency converter. These instruments are described below.



**Figure 5 – Instromet IRM-A Rotary Gas Meter with Mounted Pressure Transducer and Thermocouple**

### Pressure Transducer

The pressure of the gas flowing through the rotary gas meter is measured using a very high accuracy millivolt output pressure transducer (Omega PX429-050AI-XL). This device is powered by a 24 VDC power supply mounted in the gas train electrical box. This device has a range of 0 - 344.7 kPa (0 - 50 psia) and outputs a signal from 4 - 20 mA. The output is read by the FieldPoint module and converted to pressure and used for calculations of mass flow rate.



ATF-LS-FRL-TR010B Tube Burner	ID: 1568 Revision: 4
Authority: Technical Leader	Page: 5 of 20
Original maintained by Quality Programs; copies are uncontrolled.	

Type-K Thermocouple

An inconel sheathed, Type-K thermocouple is used to measure the gas temperature at the rotary gas meter. The temperature is read using a calibrated thermocouple FieldPoint unit with a range of -270 °C through 1770 °C using cold junction compensation. This data is used for calculations of the mass flow rate of the gas.

Pepperl+Fuchs KFD2-UFC-Ex1.D Universal Frequency Converter

The Universal Frequency Converter is used to transform the frequency output of the rotary gas meter into a current signal that can be read by the FieldPoint module connected to the DAQ system. This device is not involved in the flow of gas; it is an electrical component that allows the frequency signal from the rotary gas meter to be measured by the existing DAQ. This device is mounted in the electrical box near the natural gas train in the plenum and is shown below on the right side of Figure 6. \\* MERGEFORMAT

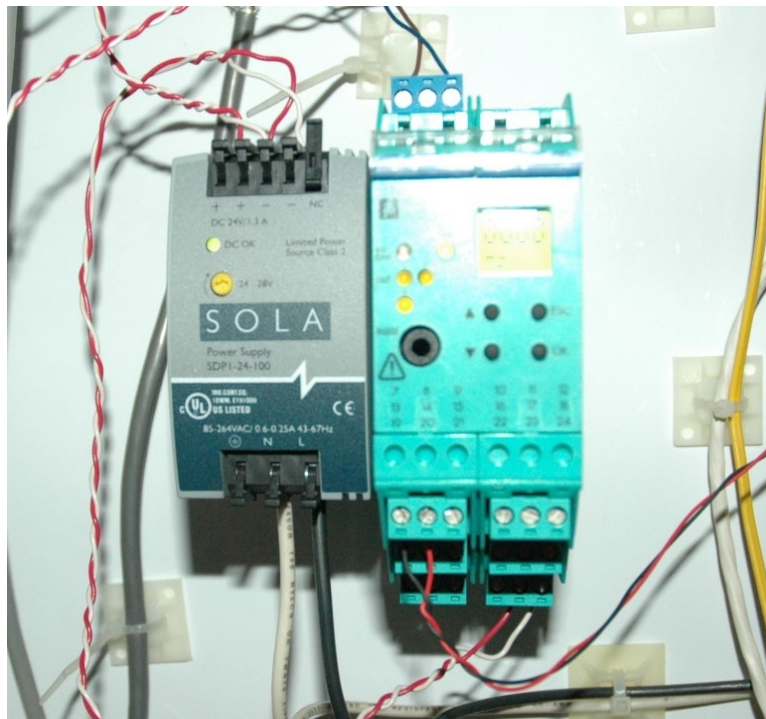

**Figure 6 – Pepperl+Fuchs KFD-UFC-1.D Universal Frequency Converter and SOLA 24 VDC Power Supply**



ATF-LS-FRL-TR010B Tube Burner	ID: 1568 Revision: 4
Authority: Technical Leader	Page: 6 of 20
Original maintained by Quality Programs; copies are uncontrolled.	

### Masoneilan Flow Control Valve

A pneumatically actuated flow control valve that is used to restrict the amount of flow allowed to discharge from the burner. This device is driven by compressed air supplied through a 0.64 cm (1/4 inch) tube and controlled by an analog voltage input. The compressed air is stored in a large tank at the south end of the mezzanine. The measured flow rate from the IRM-A rotary gas meter is used in a PID feedback control loop in order to adjust this valve to produce the desired flow rate. The control loop is designed to operate using the heat release rate parameter, and determination of this value as a function of the volume flow rate requires the use of continuous measurements of the heat content, specific gravity, temperature, and pressure of the gas. Measurements of all of these parameters must be made in order to accurately control the heat release rate by means of this valve. The device is shown below in Figure 7 \\* MERGEFORMAT . The compressed air tube is attached to the regulator on the bottom left of the device. Prior to the control valve, the compressed air passes through a desiccant filter to remove any water from the air. The pressure gauges on the control valve indicate the inlet air pressure, and a ball indicator on the front panel displays the position of the valve. In Figure 7, the valve is shown “closed” position.



**Figure 7 – Masoneilan Flow Control Valve**



ATF-LS-FRL-TR010B Tube Burner	ID: 1568 Revision: 4
Authority: Technical Leader	Page: 7 of 20
Original maintained by Quality Programs; copies are uncontrolled.	

### ***BURNER DESCRIPTION***

The tube burner is capable of producing fires as large as 6 MW. It has a height of 95 cm above the floor and plan dimensions of 162 cm x 122 cm. The burner consists of eleven parallel tubes which have 3.8 mm holes drilled along the top side with a spacing of 2.54 cm. These tubes are the release point for the natural gas. The tubes are divided in half with the ends at the center of the burner capped. The opposite ends are connected to manifolds at each side of the burner that distribute natural gas. The tubes are grouped into “banks” (numbered 1-4). The banks are opened and closed independently using solenoid valves. Banks are opened successively to increase the fire size. There are also two tubes which run perpendicular to and beneath the main tube banks which serve as pilot ignition tubes. The pilot tubes have 1.85 mm holes drilled along the top with a spacing of 1.3 cm. The fuel banks and pilot banks are fed by a 7.6 cm (3 inch) distribution pipe which is connected to the natural gas train by 7.6 cm (3 inch) stainless steel braided hose. Figure 8 \\* MERGEFORMAT shows the tube burner with the pilot banks ignited. A 10,000 V spark igniter is used to ignite the fuel passing through the pilot tubes. An electronic photoelectric sensor (Fireye) is used to monitor the presence of a flame at the pilot tubes.



**Figure 8. Tube Burner (shown with pilot bank ignited)**



ATF-LS-FRL-TR010B Tube Burner	ID: 1568 Revision: 4
Authority: Technical Leader	Page: 8 of 20
Original maintained by Quality Programs; copies are uncontrolled.	

### Burner Solenoid Valves

There five separate solenoid valves used to control the output of the tube burner. They are normally closed valves each intended to activate at various heat release rates, allowing additional banks to open as fire sizes increase up to 6 MW. The standard activation heat release settings for the valves are shown below in Table 1. The solenoid valve used to control tube bank 4 is shown below in Figure 9. \\* MERGEFORMAT

**Table 1 - Solenoid valve activation heat release rates**

Solenoid Valve	Activation HRR (kW)
Pilot	0
Tube Bank "1"	4500
Tube Bank "2"	3000
Tube Bank "3"	1500
Tube Bank "4"	400



**Figure 9 – Solenoid valve connected to tube bank "4"**



ATF-LS-FRL-TR010B Tube Burner	ID: 1568 Revision: 4
Authority: Technical Leader	Page: 9 of 20
Original maintained by Quality Programs; copies are uncontrolled.	

### Regulator for Burner Pilot Tubes

A pressure regulator is placed in line with the pilot solenoid valve to limit the amount of flow exiting the solenoid valve. Figure 10 \\* MERGEFORMAT shows a photograph of the pressure regulator. The use of this regulator makes setting the heat release rate of the burner accurately below 400 kW impossible. Instead, the flow rate is generally maintained by the set pressure of the regulator at a steady 250 kW. As a result, the tube burner should not be used to provide calibrated heat release rates below 400 kW.



**Figure 10 – Pressure regulator (center) and solenoid valve (left) for gas burner pilot tube**

### Fireye Flame Safeguard Controller

This device is connected to the burner solenoid valves as a safeguard against releasing natural gas into the laboratory. It is mounted to the base of the tube burner and contains a UV flame detector that prevents the solenoid valves to the primary tube banks from opening if the pilot flame is not lit. The device provides an alarm signal and shuts off the flow of gas if no pilot flame is detected for 10 seconds.

The Fireye provides activation power to the burner solenoid valves. When the pilot flame is lit and detected, the Fireye provides input power to a set of relays. The relays are powered by the Fireye controller and controlled by the FieldPoint module. The input power from the Fireye is used to switch on the burner solenoid valves when the relay is activated. The Fireye device can be seen in the lower left corner of Figure 11 and the relays can be seen \\* MERGEFORMAT \\* MERGEFORMAT along the right side of the circuit box below the electrical conduit ports.



ATF-LS-FRL-TR010B Tube Burner	ID: 1568 Revision: 4
Authority: Technical Leader	Page: 10 of 20
Original maintained by Quality Programs; copies are uncontrolled.	

\\* MERGEFORMAT \\* MERGEFORMAT



**Figure 11 – Gas burner electrical circuit box containing Fireye (bottom left corner), FieldPoint Module (top) and solid state relays (right)**

The Fireye is also used to control three LED lights on the front of the gas burner electrical circuit box, which are shown in Figure 12. The green light on the left indicates that the Fireye unit has 120 VAC power supplied. The green light in the middle indicates that the solenoid valve for the pilot tubes is in the open position. The red light on the right indicates that the Fireye flame detector has indicated an unsafe condition and disabled all solenoid valves to prevent the release of gas.



**Figure 12 - Gas burner electrical circuit box with LED indicator lights**



ATF-LS-FRL-TR010B Tube Burner	ID: 1568 Revision: 4
Authority: Technical Leader	Page: 11 of 20
Original maintained by Quality Programs; copies are uncontrolled.	

### ***FUEL DESCRIPTION***

The primary type of fuel used in the tube burner is natural gas, which is composed primarily of methane. See Appendix A for more information on the fuel used in the tube burner.

### ***DATA ACQUISITION***

Data acquisition for the tube burner is achieved using National Instrument (NI) FieldPoint modules. There are two sets of FieldPoint modules that are used to control and monitor the tube burner. The FieldPoint modules and the instrumentation attached to them are listed in Table 2. The FieldPoint modules are ethernet based control modules.

**Table 2. FieldPoint Setup and Locations**

FieldPoint Name (COMM Resource)	Physical Location	Devices Attached	Quantities Measured/Controlled	FieldPoint Module Address	Channel	Wiring Terminals
Gas Train (10.243.235.36)	Electrical Box Adjacent to Gas Train	P&F KFD2 Universal Frequency Converter	Volumetric Flow Rate	FP-AI-110 @ 3	0	(2,18)
		Masonellan Flow Control Valve	Valve Position	FP-AO-200 @ 1	0	(1,2)
		Inconel Type-K Thermocouple	Gas Temperature	FP-TC-120 @2	0	(1,2)
		OmegaDyne Pressure Transducer	Gas Pressure	FP-TC-120 @2	1	(3,20)
Gas Burner (10.243.235.35)	Electrical Box Underneath Tube Burner	Green Power LED Relay	Open/Closed	FP-DO-410 @ 1	0	(1,2)
		Tube Bank 4 Solenoid Valve	Open/Closed	FP-DO-410 @ 1	1	(3,4)
		Tube Bank 3 Solenoid Valve	Open/Closed	FP-DO-410 @ 1	2	(5,6)
		Tube Bank 2 Solenoid Valve	Open/Closed	FP-DO-410 @ 1	3	(7,8)
		Tube Bank 1 Solenoid Valve	Open/Closed	FP-DO-410 @ 1	4	(9,10)
		FireEye Reset Warning Alarm Relay	Open/Closed	FP-DO-410 @ 1	5	(11,12)
		FireEye Warning Alarm	Flame Present?	FP-DO-301 @ 2	0	(1,17)

## **FireTOSS Calculations**

### ***HEAT RELEASE RATE CALCULATION***

The heat release rate (HRR) of the fire is calculated using the flow rate of the fuel and the combustion properties of the fuel. Equation (1.1) expresses the HRR in terms of the mass flow rate of the fuel.

$$\dot{Q} = \eta \cdot \dot{m} \cdot \Delta H_{C,net} \quad (1.1)$$

where

$\dot{Q}$  = heat release rate of the burner (kW)

$\eta$  = combustion efficiency of the fuel (assumed to be 1 for gaseous fuels).

$\dot{m}$  = mass flow rate of the fuel (kg/s)

$\Delta H_{C,net}$  = net heat of combustion of the fuel (kJ/kg)

Equation (1.1) can be expressed in terms of the volumetric flow rate of the fuel.



ATF-LS-FRL-TR010B Tube Burner	ID: 1568 Revision: 4
Authority: Technical Leader	Page: 12 of 20
Original maintained by Quality Programs; copies are uncontrolled.	

$$\dot{Q} = \eta \cdot \rho \cdot \dot{V} \cdot \Delta H_{C,net} \quad (1.2)$$

where

$\rho$  = density of the fuel (kg/m<sup>3</sup>)

$\dot{V}$  = volumetric flow rate of the fuel (m<sup>3</sup>/s)

The density term in Equation (1.2) refers to the density of the natural gas at the point where the volumetric flow rate ( $\dot{V}$ ) is measured. The natural gas density is measured by the combustion calorimeter which operates at ambient conditions [1]. Therefore, the measured density must be corrected to correlate with the conditions in the gas train. Using the ideal gas law, the density in the gas train can be expressed as:

$$\rho_2 = \frac{SG(NG) P_2}{R_{air} T_2} \quad (1.3)$$

where

$SG(NG)$  = specific gravity of the natural gas measured at the combustion calorimeter

$R_{air}$  = gas constant for air (0.287 kJ/kg/K)

$\rho_2, P_2, T_2$  = gas properties in the natural gas train at the location of the flow meter

An example of heat release for natural gas calculated for a variety of flow rates is shown in Table 3.

**Table 3 - Heat Release Rate vs. Natural Gas Flow Rate**

HRR (kW)	Natural Gas Flow Rate (SLPM)
500	869.6
1000	1739.3
2000	3478.5
3000	5217.8
4000	6957.0

## Uncertainty and Accuracy

The uncertainty of the burners was estimated using the guidelines of the National Institute of Standards and Technology (NIST) Technical Note 1297 [1], Special Publication 1007 [2] and the



ATF-LS-FRL-TR010B Tube Burner	ID: 1568 Revision: 4
Authority: Technical Leader	Page: 13 of 20
Original maintained by Quality Programs; copies are uncontrolled.	

NIST Uncertainty Workshop [3]. The combined standard uncertainty of the heat release rate is a combination of the uncertainty of its components, including flow, density, and heat of combustion, among other factors, and is given by the following equation:

$$u_c(\dot{Q}) = \sqrt{\sum s_i^2 u(x_i)^2} \quad (1.4)$$

where:

- $u_c(\dot{Q})$  = Combined standard uncertainty of the burner heat release rate
- $u(x_i)$  = Standard uncertainty of each heat release rate component
- $s_i$  = Sensitivity coefficient ( $\partial y / \partial x_i$ )

$$u_c(\dot{Q}) = \left[ \left( \frac{\partial \dot{Q}}{\partial SG} \right)^2 (u(SG))^2 + \left( \frac{\partial \dot{Q}}{\partial P_2} \right)^2 (u(P_2))^2 + \left( \frac{\partial \dot{Q}}{\partial T_2} \right)^2 (u(T_2))^2 + \left( \frac{\partial \dot{Q}}{\partial \dot{V}_{NG}} \right)^2 (u(\dot{V}_{NG}))^2 + \left( \frac{\partial \dot{Q}}{\partial \Delta H_{c,net}} \right)^2 (u(\Delta H_{c,net}))^2 \right]^{1/2} \quad (1.5)$$

where

- $u(SG)$  = Standard uncertainty of natural gas specific gravity measurement at the combustion calorimeter
- $u(P_2)$  = Standard uncertainty of pressure measurement in the natural gas train
- $u(T_2)$  = Standard uncertainty of temperature measurement in the natural gas train
- $u(\dot{V}_{NG})$  = Standard uncertainty of natural gas volumetric flow rate
- $u(\Delta H_{c,net})$  = Standard uncertainty of natural gas heat of combustion

Standard uncertainties for the natural gas specific gravity (0.012) and heat of combustion (1.05 MJ/kg) were computed based on an evaluation of the combustion calorimeter [4].

The uncertainty of the volumetric flow rate is a factor of the accuracy and repeatability of the IRM-A Rotary Meter. An analysis was performed to evaluate contributions from the data acquisition system, including the frequency converter, and random fluctuations in the data to the combined uncertainty of the gas flow rate. It was found that these sources were negligible in comparison to the contribution from the flow meter accuracy. These were therefore not considered in the analysis that follows.



ATF-LS-FRL-TR010B Tube Burner	ID: 1568 Revision: 4
Authority: Technical Leader	Page: 14 of 20
Original maintained by Quality Programs; copies are uncontrolled.	

Instromet lists the accuracy of the IRM-A rotary meter as  $\pm 1\%$  of the reading, and the repeatability as less than  $0.05\%$  of the reading [5]. The nominal peak flow rate through the flow meter (for a 6 MW fire) is  $0.087 \text{ m}^3/\text{s}$  (11000 CFH). The combined standard uncertainty at this flow rate is  $u(\dot{V}_{\text{NG}}) = \underline{5.0 \times 10^{-4} \text{ m}^3/\text{s}}$  (63.6 CFH).

The temperature of the natural gas in the flow meter is monitored by a K-type thermocouple with error limits of  $\pm 1.1 \text{ }^\circ\text{C}$ . The corresponding standard uncertainty, assuming a rectangular distribution, is  $u(T_2) = \underline{0.64 \text{ }^\circ\text{C}}$ . The OmegaDyne pressure transducer has an accuracy of  $\pm 0.25\%$ . At a nominal operating pressure of 200 kPa the standard uncertainty is  $u(P_2) = \underline{0.31 \text{ kPa}}$ .

Using the standard uncertainties listed above, the combined standard uncertainty of the tube burner heat release rate is calculated (using Eq. 1.4) as  $= \underline{179.9 \text{ kW}}$ . This equates to a relative combined standard uncertainty of  $3.1\%$  at a nominal heat release rate of 5890 kW.



ATF-LS-FRL-TR010B Tube Burner	ID: 1568 Revision: 4
Authority: Technical Leader	Page: 15 of 20
Original maintained by Quality Programs; copies are uncontrolled.	

## Appendix A – Calculation of Natural Gas Properties

In order to calculate the heat release rate of the burner using Equation (0.1), the properties of the gas are needed. The most typical fuel gas that will be used by the FRL to fuel the burners is natural gas. Natural gas is a mixture of gases whose major components are methane, propane, i-butane, n-butane, neopentane, i-pentane, n-pentane, nitrogen, carbon dioxide, ethane and heavier hydrocarbons with six or more carbon atoms (referred to by Washington Gas as “C6+ 47/35/17”). These component concentrations vary over time, thus varying the properties of the natural gas. Therefore, the properties of natural gas supplied to the FRL were calculated using a combustion calorimeter which measured the calorific value and specific gravity of the natural gas [4].

### Combustion Calorimeter

A Union CWD 2000 Combustion Calorimeter was used to determine the calorific value and specific gravity of the natural gas supply [6]. The caloric value was measured over a range of 35000-45000 kJ/m<sup>3</sup> and the specific gravity was measured over a range of 0.2-2.2, with respect to air. Both of these values are output as a 4-20 mA current. The calorimeter is automatically calibrated every weekday.

### Density

The density ( $\rho$ ) of natural gas is calculated in real-time throughout the test based on the specific gravity of the gas and the relationship of specific gravity to density:

$$\rho_{NG} = \frac{SG_{NG} * P}{R * T} \quad (1.6)$$

where

$\rho_{NG}$  = density of natural gas, kg/m<sup>3</sup>

$SG_{NG}$  = specific gravity of natural gas in relation to air

$P$  = pressure of gas in the gas train, Pa

$R$  = gas constant for air, 287 J/kg•K

$T$  = temperature of gas in gas train, K

The specific gravity is the average of a two minute baseline reading taken prior to the start of the test.

### Net heat of combustion

The calorific (heating) value of natural gas is determined by the combustion calorimeter used and output in kJ/m<sup>3</sup>. However, the gas property necessary for the burner calculations in Equation (1.1) is the net heat of combustion ( $\Delta H_{C, net}$ ) in units of kJ/kg. The net heat of



ATF-LS-FRL-TR010B Tube Burner	ID: 1568 Revision: 4
Authority: Technical Leader	Page: 16 of 20
Original maintained by Quality Programs; copies are uncontrolled.	

combustion of natural gas was calculated based on the heating value and the density of natural gas:

$$\Delta H_{c,gross} = \frac{C.V.}{\rho_{NG}} \quad (1.7)$$

where

$\Delta H_{c,gross}$  = gross heat of combustion of the gas mixture in kJ/kg

$C.V.$  = calorific value of natural gas in kJ/m<sup>3</sup>

$\rho_{NG}$  = density of natural gas in kg/m<sup>3</sup>

This calculation yields a value in terms of the higher heating value, which does not account for water vapor. To account for water vapor, a correlation from Bossel [7] was used to convert to the lower heating value.

$$\Delta H_{c,net} = \Delta H_{c,gross} * 0.896 \quad (1.8)$$

The heat of combustion of the natural gas is calculated as a static value for tube burners. The calorific value is the average of a two minute baseline reading taken prior to the start of the test. The natural gas density is the average density calculated during the same two minute baseline.



### Appendix B – Tube Burner Flow Chart and Wiring Diagram

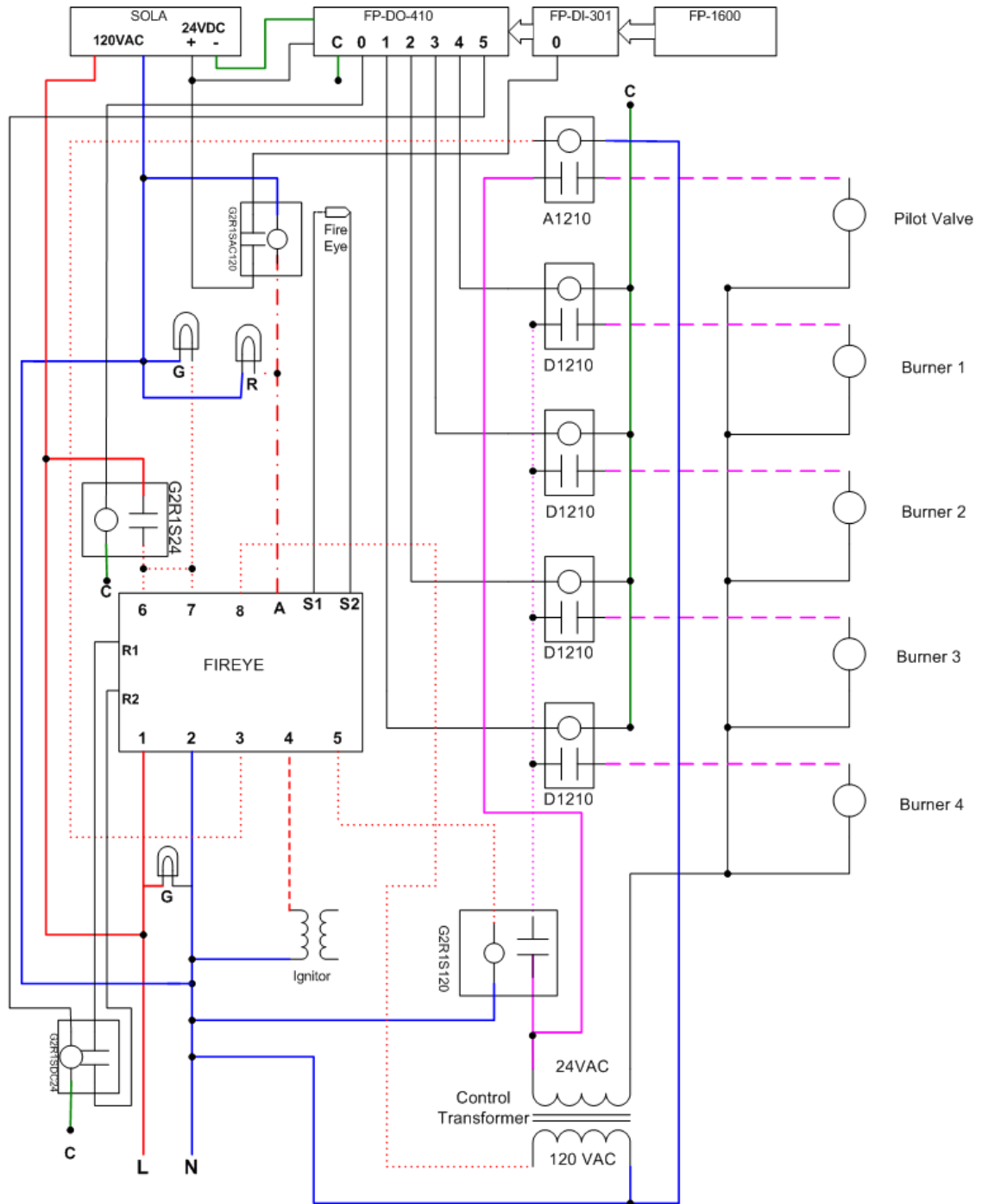

Figure 13. Wiring Diagram for Tube Burner Electrical Box

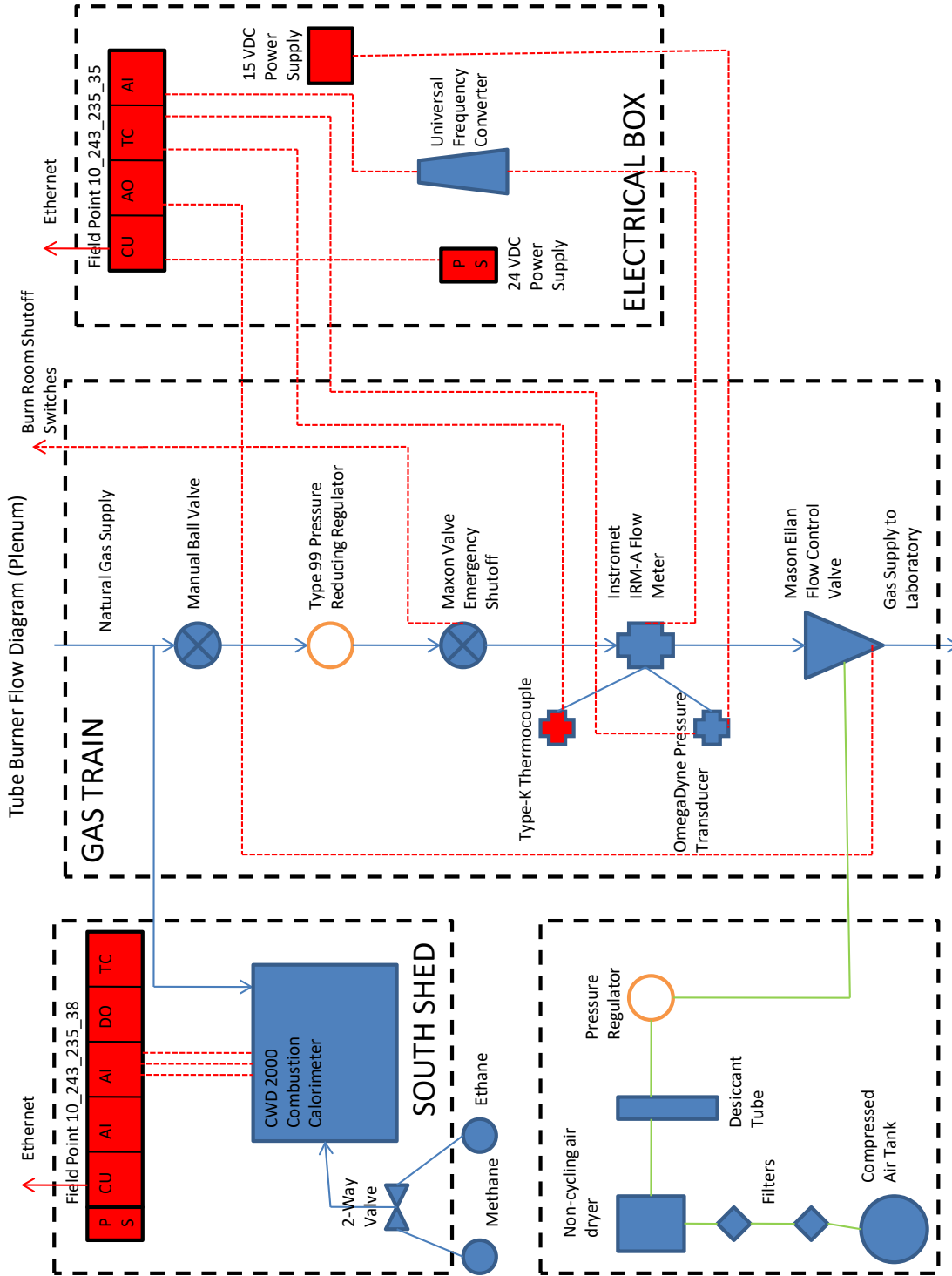

Figure 14. System Flow Chart for Components Located in Mezzanine

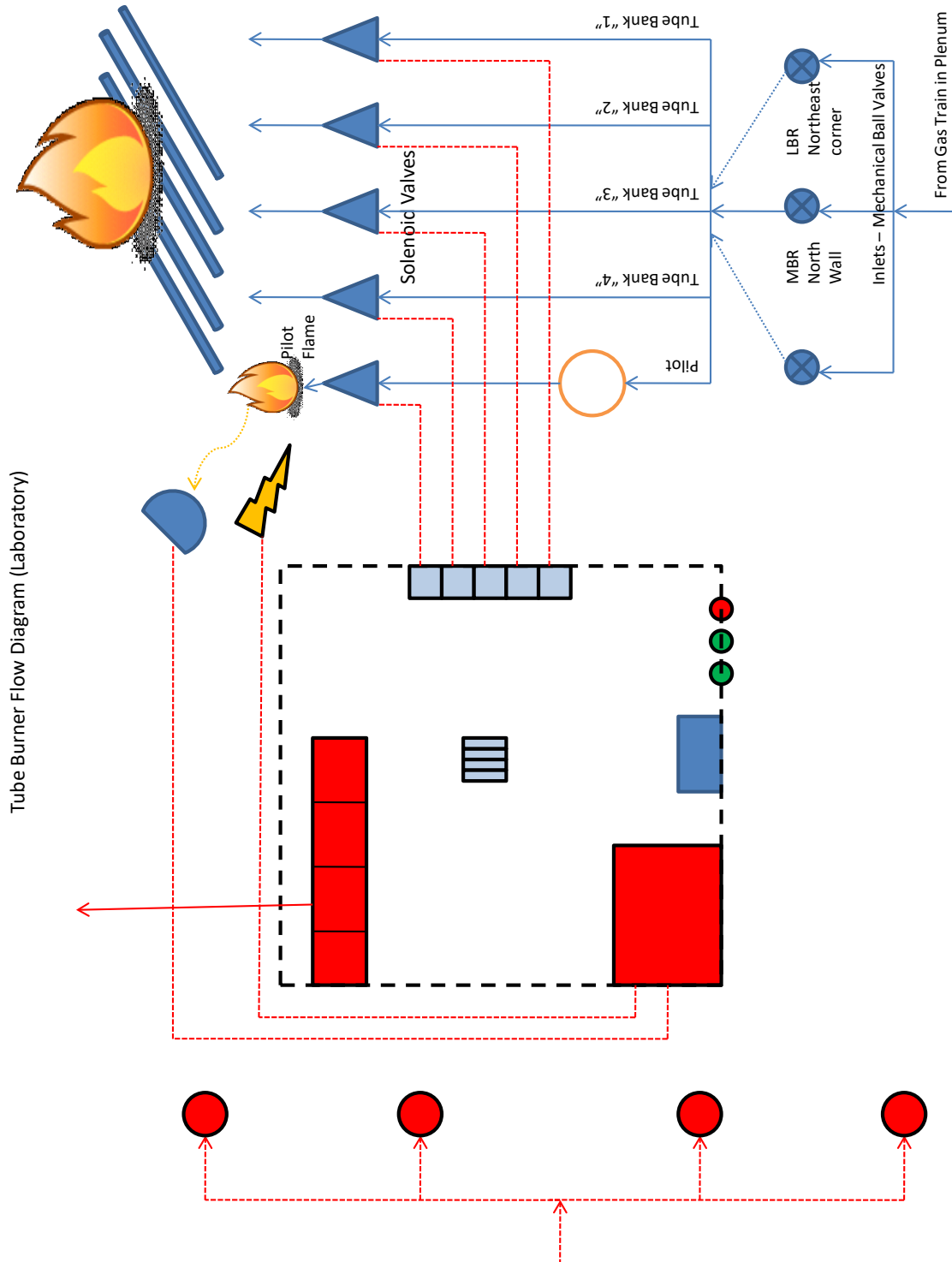

Figure 15. System Flow Chart for Tube Burner and Tube Burner Electrical Box



ATF-LS-FRL-TR010B Tube Burner	ID: 1568 Revision: 4
Authority: Technical Leader	Page: 20 of 20
Original maintained by Quality Programs; copies are uncontrolled.	

## References

1. Taylor, B. N., & Kuyatt, C. E., "NIST Technical Note 1297: Guidelines for Evaluating and Expressing the Uncertainty of NIST Measurement Results," National Institute of Standards and Technology, Gaithersburg, MD, 1993.
2. Bryant, A.R., Ohlemiller, T.J., Johnsson, E.L, Hamins, A., Grove, B.S., Guthrie, W.F., Maranghides, A., Mulholland, G.W., "Special Publication 1007," National Institute of Standards and Technology, Gaithersburg, MD, 2003
3. Guthrie, W. & Liu, H., "Hands-on Workshop on Estimating and Reporting Measurement Uncertainty," National Institute of Standards and Technology, Presentation given to CPSC, 2007.
4. ATF FRL Instruction, "Laboratory Instruction LI018: Combustion Calorimeter."
5. "IRM-A Maintenance and Instruction Manual," Instromet Inc, Houston, TX, 2001.
6. "Users Manual – CWD 2000 Combustion Calorimeter – For high speed measurement of fuel gases," Union, 2007.
7. Bossel, U., "Well-to-Wheel Studies, Heating Values, and the Energy Conservation Principle," Oberrohrdorf, Switzerland, 2003. <http://www.efcf.com/reports/E10.pdf>



ATF-LS-FRL-TR011a - Fire Products Collectors - 1 MW Square	ID: 2670 Revision: 3
Authority: Technical Leader	Page: 1 of 28
Original maintained by Quality Programs; copies are uncontrolled.	

## Scope

This Technical Reference covers the use, design and specifications of the 1 MW Square Fire Products Collector (FPC) in the Bureau of Alcohol, Tobacco, Firearms and Explosives (ATF) Fire Research Laboratory (FRL).

## Instrument Description

### *General*

The 1 MW Square FPC collects smoke and other products of combustion generated during fire experiments. A FPC consists of a collection hood connected to an exhaust duct, with air drawn through the duct by one or more variable speed fans. A FPC serves two purposes:

- 1) To remove combustion products from a laboratory space, and
- 2) To optimize the flow field for measurement and quantitative analyses of the combustion products.

A FPC provides four primary quantities: heat release rate (HRR), convective heat release rate (CHRR), gas species production and smoke production [1]. When used in conjunction with a weighing device, such as a load cell, the mass loss rate (MLR) of the burning object can be calculated. Gas species yields, smoke yield, and the effective heat of combustion of a burning item can then be calculated based on the MLR.

The 1 MW Square FPC is located in the southeast corner of the FRL's Medium Burn Room (MBR). Figure 1 shows a photograph of the collection hood and exhaust duct for the 1 MW square FPC.



ATF-LS-FRL-TR011a - Fire Products Collectors - 1 MW Square	ID: 2670 Revision: 3
Authority: Technical Leader	Page: 2 of 28
Original maintained by Quality Programs; copies are uncontrolled.	



**Figure 1. 1 MW Square FPC**

***Hood and Collection System***

**Physical Dimensions**

Figure 2 shows a plan view schematic of the 1 MW Square FPC collection hood in the MBR. The square 3.0 m collection hood transitions to a circular exhaust duct with an internal diameter of 0.65 m. A 0.39 m diameter orifice plate is located near the entrance of the exhaust duct, approximately 4.8 m above the floor. The orifice enhances mixing of the fire products prior to reaching the instrumentation locations. The exhaust duct has a vertical run of approximately 12 m before transitioning to a horizontal run above the MBR ceiling. The base of the collection hood is 2.9 m above the MBR floor; however skirts can be added to reduce the height to 2.1 m.



ATF-LS-FRL-TR011a - Fire Products Collectors - 1 MW Square	ID: 2670 Revision: 3
Authority: Technical Leader	Page: 3 of 28
Original maintained by Quality Programs; copies are uncontrolled.	

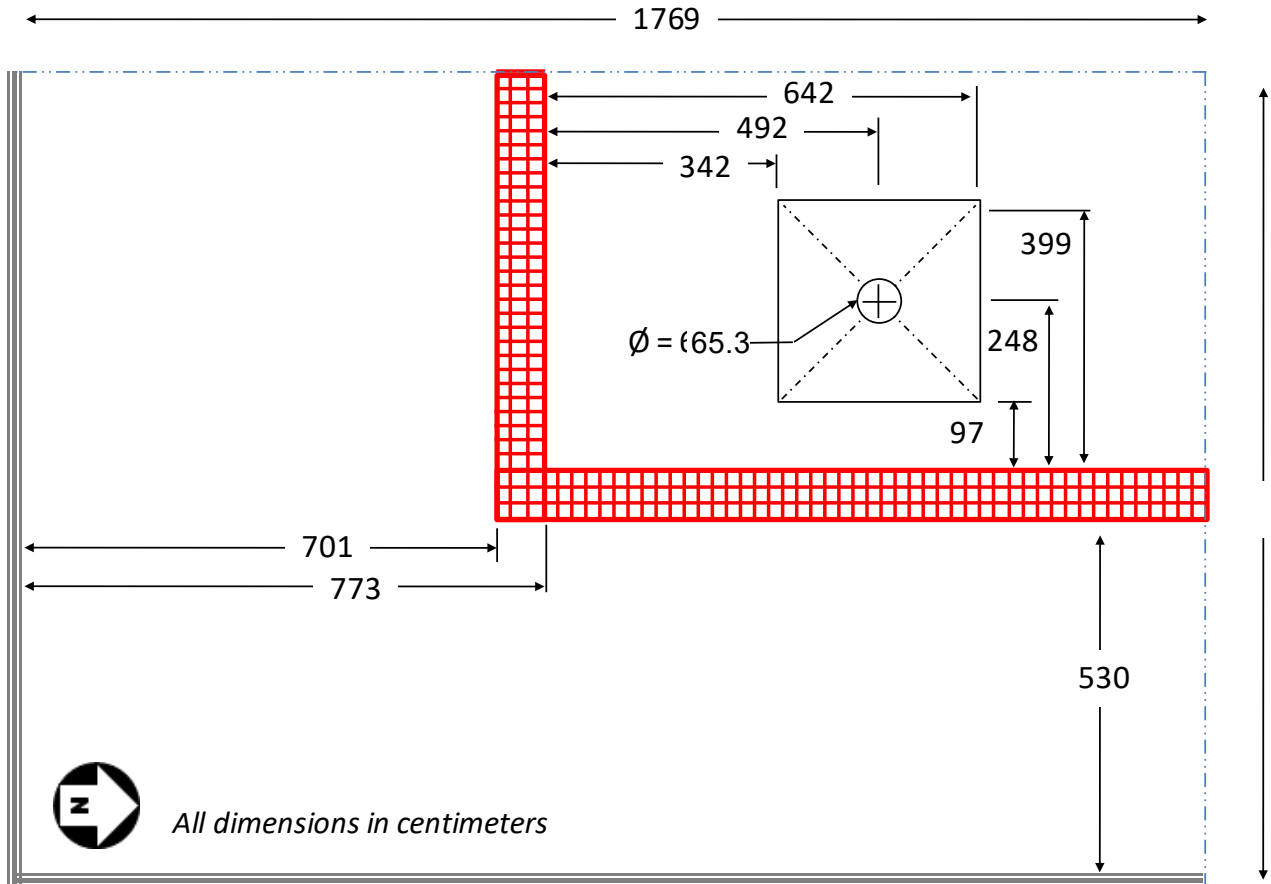

Figure 2: Plan view of 1 MW Square FPC in the MBR.

### Instrument Locations

Instruments are located at two levels in the FPC exhaust duct, as shown in Figure 3. The first instrument station is located approximately 3.8 m downstream of the inlet orifice. This station is located below the MBR ceiling and is accessible via a fixed platform. The first instrument station is used for flow measurement and gas sampling. The second instrument station is located approximately 6 m downstream of the first station, at the mezzanine level directly above the MBR. This station houses the laser and white light smoke measurement instruments.

### Flow Control

Flow in the FPC is controlled by a system of variable speed fans and actuated dampers that are programmed to maintain a fixed mass flow rate. The system is operated by a PC in the FRL Control Room. The FRL FPC's were designed to flow 6.8 kg/s (12,000 SCFM) per 1 MW heat release rate; this flow rate represents the approximate maximum capacity of the 1 MW square FPC.

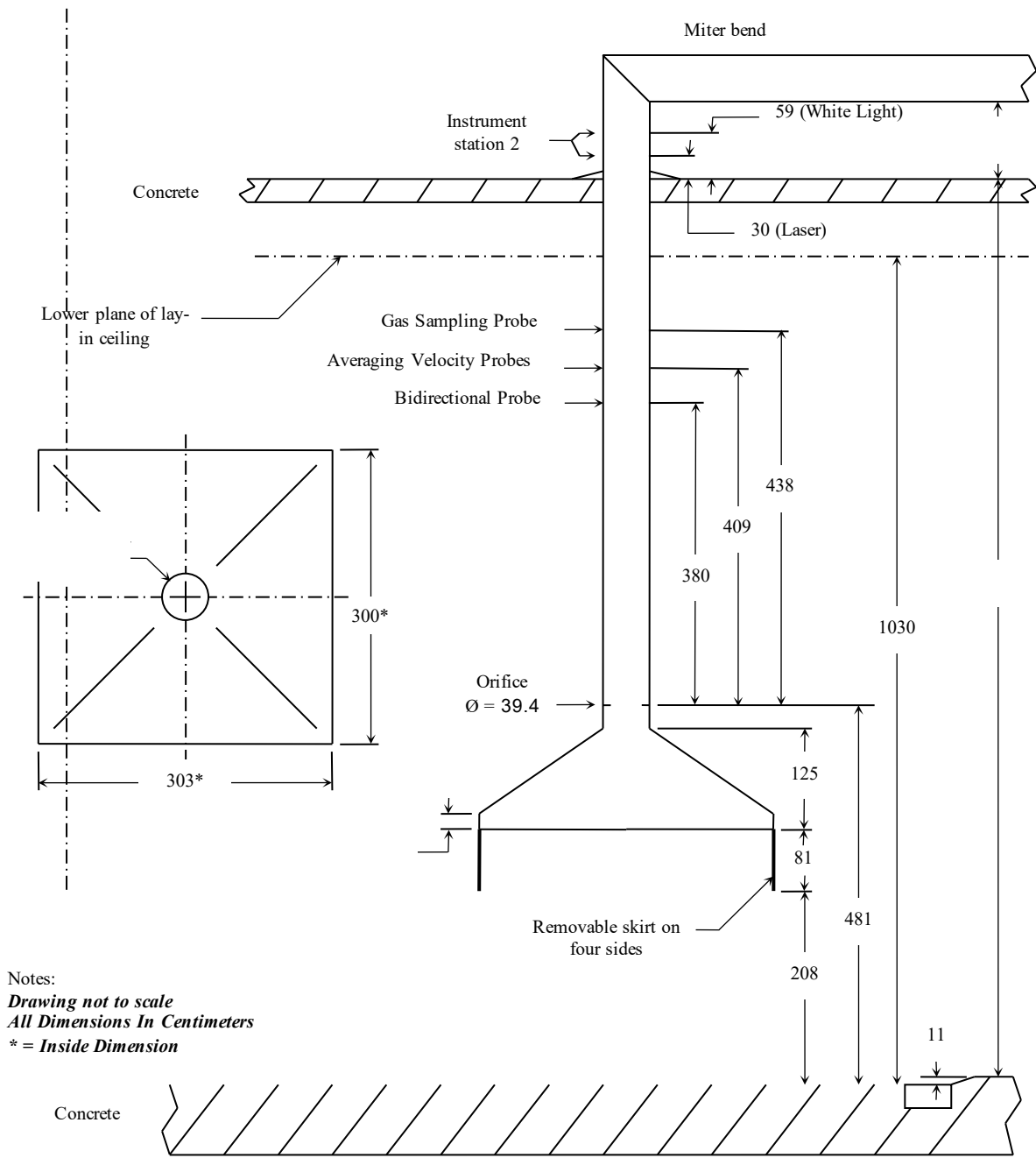

Notes:  
*Drawing not to scale*  
*All Dimensions In Centimeters*  
*\* = Inside Dimension*

**Figure 3: Elevation view of 1 MW Square FPC in the MBR.**



ATF-LS-FRL-TR011a - Fire Products Collectors - 1 MW Square	ID: 2670 Revision: 3
Authority: Technical Leader	Page: 5 of 28
Original maintained by Quality Programs; copies are uncontrolled.	

## ***Instrumentation***

The 1 MW Square FPC is equipped with instrumentation to measure gas species concentrations, temperature, velocity, and smoke concentration.

### **Gas Species Measurement**

The system of instrumentation used to measure gas species concentrations consists of a gas sampling probe located in the duct, tubing to transport the sample, a pump, sample conditioning equipment, and a gas analyzer.

Figure 4 shows a schematic of the gas sampling probe used in the 1 MW Square FPC. The gas sampling probe is a stainless steel tube with an outside diameter of 19.1 mm (0.75 inch) containing 30 sampling holes positioned at even intervals across the length of the probe. The sampling holes have diameters of either 3mm or 4 mm, and are spaced at 20 mm intervals. Figure 5 shows a detailed schematic of the gas sampling probe.

The gas sampling probe is installed across the center of the exhaust duct with the sampling holes facing downstream. The probe is located 4.4 m downstream of the inlet orifice. The sample is drawn from both ends of the sampling probe and transported to the gas analysis rack through a single 9.5 mm (3/8 inch) diameter Teflon gas sampling line.



ATF-LS-FRL-TR011a - Fire Products Collectors - 1 MW Square	ID: 2670 Revision: 3
Authority: Technical Leader	Page: 6 of 28
Original maintained by Quality Programs; copies are uncontrolled.	

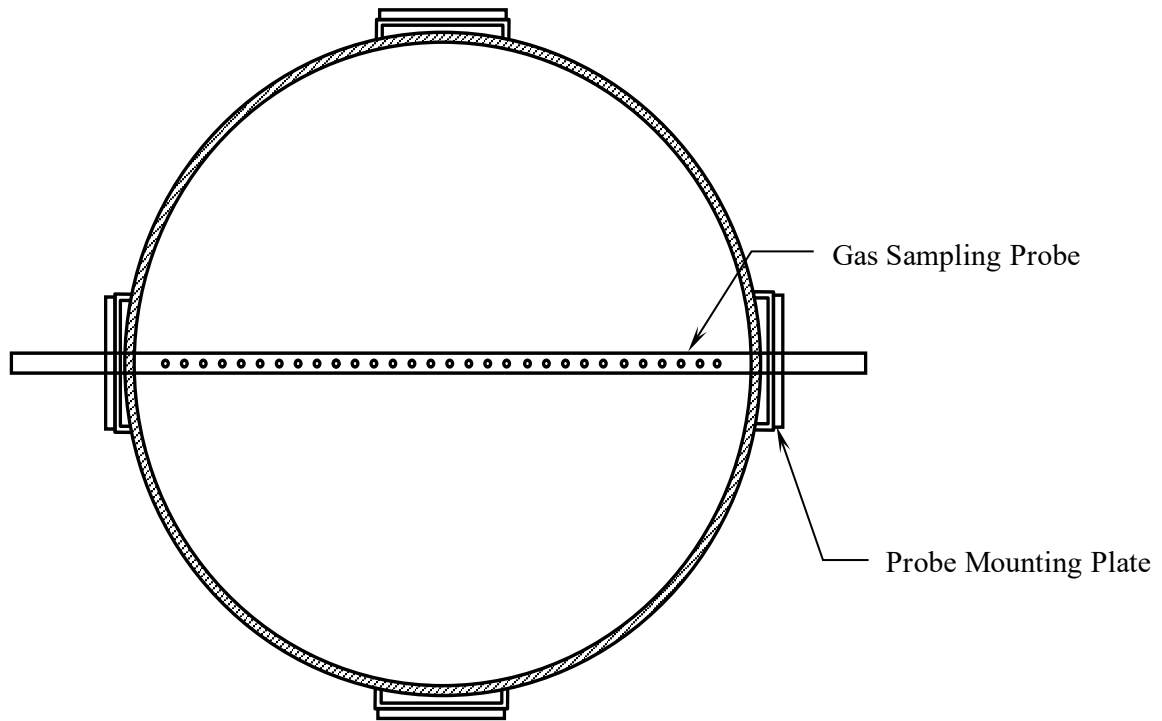

**Figure 4. Schematic of the gas sampling probe mounted in the duct**

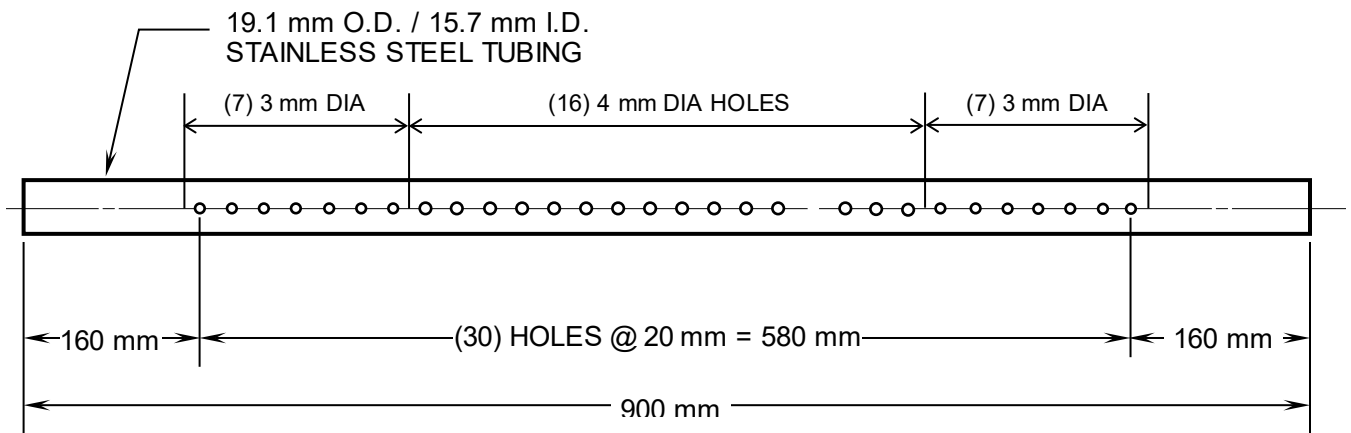

**Figure 5. Detailed schematic of the gas sampling probe showing hole locations**

Tubing from the gas sampling probe is connected to a gas analysis rack constructed by Fire Testing Technology Limited (FTT), shown in Figure 6. This rack, located in a conditioned space on the mezzanine level above the MBR, includes a Servomex 4100C Xentra gas analyzer, gas train, pressure and flow control, filtering, and moisture removal.



ATF-LS-FRL-TR011a - Fire Products Collectors - 1 MW Square	ID: 2670 Revision: 3
Authority: Technical Leader	Page: 7 of 28
Original maintained by Quality Programs; copies are uncontrolled.	



**Figure 6: Photo of the 1 MW Square FPC gas analysis rack**

The gas analyzer is configured to measure oxygen, carbon monoxide and carbon dioxide. Table 1 lists the output range for these three gas species measured for the 1 MW FPC. Additional details on the gas analyzer rack are provided elsewhere [2 - 4].

A delay exists between the time that the gas sample is extracted from the duct and the time it reaches the analyzer. This delay time is determined by introducing a step-change in gas composition flowing past the gas sampling probe and monitoring the output of the analyzer for change in measured gas concentration. The delay time used in each experiment is documented in the FireTOSS datasheet. The gas analyzer was modified by Servomex to permit higher sample flow rates in order to reduce the sample delay times [4, 5].

**Table 1. Servomex 4100C gas species measurement ranges.**

Gas Species	Range
Oxygen (O <sub>2</sub> )	0 – 25 %
Carbon Dioxide (CO <sub>2</sub> )	0 – 10 %
Carbon Monoxide (CO)	0 – 1 %



ATF-LS-FRL-TR011a - Fire Products Collectors - 1 MW Square	ID: 2670 Revision: 3
Authority: Technical Leader	Page: 8 of 28
Original maintained by Quality Programs; copies are uncontrolled.	

## Flow Measurement

The flow of gases in the duct is measured using a pressure transducer, velocity probe, and thermocouple.

Details on the use of differential pressure probes for velocity measurements are contained in the Laboratory Instruction [6].

### Pressure Transducer

A Setra model 267 pressure transducer with a range of 0 – 620 Pa (0 – 2.5 inches of water) and an output of 4 – 20 mA is used for differential pressure measurement in the 1 MW Square FPC [7]. The transducer is connected to the differential pressure probes through a solenoid valve that can be closed to facilitate baseline readings and probe purging.

### Velocity Probe

Velocity measurements in the 1 MW Square FPC are performed using a bi-directional probe [8]. Figure 7 shows a schematic of the probe. The probe consists of two ports; one facing upstream and the other downstream. The differential pressure measured between the two ports is used to calculate the velocity at the probe location. A flow shape factor is applied to calculate the average duct velocity. The probes are mounted to the exterior of the duct via a 19 cm diameter mounting plate. All components are constructed of stainless steel. Additional details on the use of differential pressure probes for velocity measurements are contained in the Laboratory Instruction [6] and Technical Reference [9].

The 1 MW Square FPC duct is equipped with additional velocity probes. A pair of VOLU-probe/1SS Stainless Steel Pitot Airflow Traverse Probes [10] is mounted approximately 30 cm downstream of the bi-directional probes, as shown in Figure 3. Figure 8 shows a schematic of the probe. The probe consists of two manifolds; one each for static and total pressure measurement. Each manifold has pressure ports spaced at equal area intervals, producing a pressure representing the instantaneous average across the duct. The probes are mounted to the exterior of the duct via a 15 cm x 15 cm mounting plate on one end, with the opposite end secured by a pin support. Two probes are mounted at a 90° angle, per manufacturer specifications [11]. All components are constructed of stainless steel. Additional details on the use of differential pressure probes for velocity measurements are contained in the Laboratory Instruction [6] and Technical Reference [12].



ATF-LS-FRL-TR011a - Fire Products Collectors - 1 MW Square	ID: 2670 Revision: 3
Authority: Technical Leader	Page: 9 of 28
Original maintained by Quality Programs; copies are uncontrolled.	

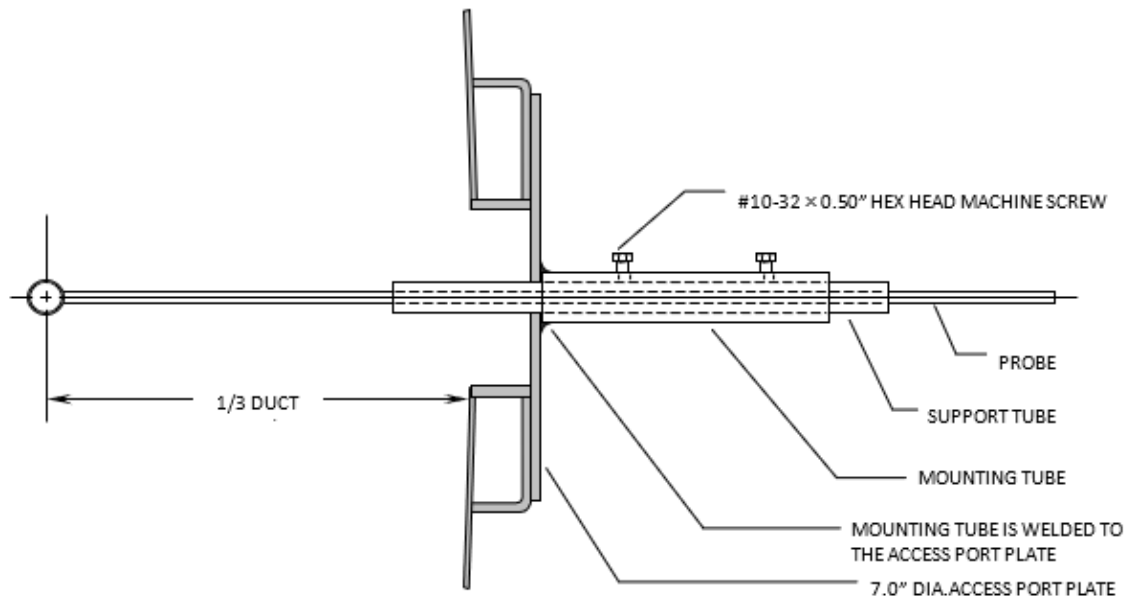

Figure 7: Schematic of the bi-directional probes.

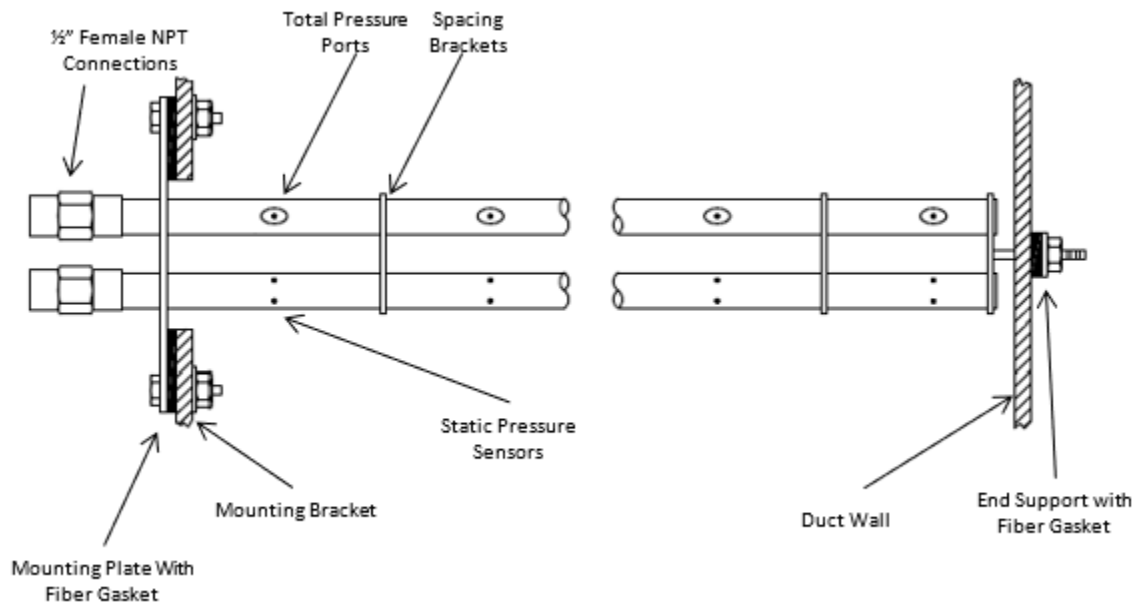

Figure 8: Schematic of the velocity traverse probes [10].



ATF-LS-FRL-TR011a - Fire Products Collectors - 1 MW Square	ID: 2670 Revision: 3
Authority: Technical Leader	Page: 10 of 28
Original maintained by Quality Programs; copies are uncontrolled.	

### Thermocouple

Two 1.5 mm (0.062 inch) Inconel-sheathed Type K special limits of error (SLE) thermocouples are used to monitor the gas temperature in the 1 MW FPC duct. Type K thermocouples have a peak temperature range of approximately 1250 °C (2282 °F). Type-K SLE thermocouple wire has a minimum accuracy of the greater of 1.1°C or 0.4% of the temperature reading over 0°C. Additional information on thermocouples can be found in the Laboratory Instruction [13].

### **Smoke Measurement**

Smoke is measured in the 1 MW Square FPC using optical density meters (ODMs) [14, 15]. Both laser and white-light ODMs are used in the 1 MW Square FPC. The ODM access ports are located approximately 6 m downstream of the velocity and gas sampling probes.

The laser ODM uses a low-power (0.5 mW) Helium-Neon (HeNe) laser that emits continuous light at 632 nm. The laser ODM uses two photodiode detectors; the main detector is used to measure the beam intensity as it is attenuated by the smoke and fire gases in the FPC. A compensating detector located near the laser head is used to account for changes in the laser output during a test so that these are not erroneously attributed to smoke attenuation by the main detector.

The white-light ODM, which is manufactured by Fire Testing Technology (FTT), uses a broad-band visible (white) light source. The light source consists of a halogen lamp and a series of lenses and apertures that combine to create a nearly collimated beam with a 25 mm diameter at the source. The light receiver uses a silicon photoelectric cell in front of which is a spectral filter to accommodate the human eye. The source and receiver are mounted to a rigid frame on opposite sides of the duct.

### **Data Acquisition**

Data acquisition for the 1 MW Square FPC is achieved using an Allen Bradley (AB) SLC 500 series Programmable Logic Controller (PLC). The system is equipped with a SLC 5/05 processor which has an IP address of 10.243.235.183. The FPC instrumentation and the corresponding FireTOSS tag are listed in Table 2. The PLC is located inside a cabinet on the east wall of a climate controlled instrument shed located on the mezzanine level, above the MBR. This shed houses the data acquisition and gas analysis instrumentation for all of the MBR FPCs.



ATF-LS-FRL-TR011a - Fire Products Collectors - 1 MW Square	ID: 2670 Revision: 3
Authority: Technical Leader	Page: 11 of 28
Original maintained by Quality Programs; copies are uncontrolled.	

**Table 2. Data Acquisition Setup**

<b>Devices Attached</b>	<b>Quantity Measured</b>	<b>FireTOSS Tag</b>
Laser ODM – Main	Light transmission	AB183_AI01_08
Laser ODM – Compensating	Light transmission	AB183_AI01_09
White Light ODM	Light transmission	AB183_AI01_10
Gas Analyzer – O <sub>2</sub>	Gas Concentration	AB183_AI04_04
Gas Analyzer – CO <sub>2</sub>	Gas Concentration	AB183_AI04_03_F
Gas Analyzer – CO	Gas Concentration	AB183_AI04_05
Pressure Transducer	Pressure	AB183_AI04_01_F
Thermocouple 1	Temperature	AB183_TC11_01
Thermocouple 2	Temperature	AB183_TC11_02

### **Measurement Range**

The practical HRR measurement range for the 1 MW Square FPC is from 10 kW to 1700 kW. This represents a range of HRR values over which the 1 MW FPC has a linear response. The minimum change in HRR that can be resolved with the 1 MW Square FPC is approximately 5 kW. Data from calibration experiments performed over the full measurement range of the FPC are shown in Appendix A.

### **Calibration**

A calibration burner [16] is used to determine the calibration factor, or C Factor, for a FPC. The type of calibration burner is selected based on the desired maximum HRR needed for the calibration. For the 1 MW Square FPC, sand burners [17] are used to determine the C Factor.

### **Calculations**

The calculations used to determine the HRR, and other output quantities, from the FPC are defined in the FPC Laboratory Instruction [1].

### **Uncertainty and Accuracy**

Fire Products Collectors are designed to provide four primary quantities: heat release rate (HRR), convective heat release rate (CHRR), gas species production and smoke production. The uncertainty associated with each of these quantities, calculated from measurements in the 1 MW Square FPC, was estimated using the guidelines of the National Institute of Standards and Technology (NIST) Special Publication 1007 [18], Technical Note 1297 [19], and the NIST Uncertainty Workshop [20]. The analysis outlined below is based primarily on data collected from natural gas fires generated using sand burners; the burner output was fixed for a period of five minutes at progressively increasing HRR levels [1, 17]. Uncertainty was calculated for nominal fire sizes of 50 kW, 500 kW and 1100 kW, representing low, middle and high ends of the operating range.



ATF-LS-FRL-TR011a - Fire Products Collectors - 1 MW Square	ID: 2670 Revision: 3
Authority: Technical Leader	Page: 12 of 28
Original maintained by Quality Programs; copies are uncontrolled.	

The combined standard uncertainty for a calculated output  $y$ , based on a number ( $i$ ) of uncorrelated input quantities  $x_i$ , is a combination of the uncertainty of each component. It is expressed mathematically by the following equation:

$$u_c(y) = k \sqrt{\sum s_i^2 u(x_i)^2} \quad (1)$$

where:

- $u_c(y)$  = Combined standard uncertainty in the output  $y$
- $u(x_i)$  = Standard uncertainty of each component  $x_i$
- $s_i$  = Sensitivity coefficient associated with each component ( $\partial/\partial x_i$ )
- $k$  = Coverage factor

The expression used to calculate the oxygen consumption HRR is a complex function of multiple variables and physical constants [1, 21]. The formulations used to calculate CHRR, gas species production and smoke production are considerably simpler and use many of the same measured input variables [1]. The approach taken in this analysis was to calculate the uncertainty in the HRR first. This necessitates calculating the standard uncertainty for most of the variables and parameters used in the other output quantities. A spreadsheet formulation was used to apply Equation (1) to perform the uncertainty calculations [22].

Table 3 summarizes the combined standard uncertainty for each output quantity of the 1 MW Square FPC. The HRR, CHRR and CO<sub>2</sub> production rate values are based on data collected from the natural gas calibration burner experiments. Because the natural gas fires produce relatively little smoke, data for the rate of smoke release (RSR) are from separate experiments. The RSR data is from a corrugated cardboard fire with a peak HRR of approximately 300 kW. Details on how these uncertainty values were determined are provided in the sections that follow.

**Table 3. Uncertainty Summary**

Quantity	Calculated Value	Combined Standard Uncertainty	Relative Uncertainty
Heat Release Rate (HRR)	520 kW	34	6.4 %
Convective Heat Release Rate	385 kW	24	6.3 %
Mass Production Rate – CO <sub>2</sub>	26 g/s	1.6	6.3 %
Mass Production Rate – CO	0.07 g/s	0.01	13.9 %
Rate of Smoke Release – Laser	2.7 m <sup>2</sup> /s	0.14	5.5 %



ATF-LS-FRL-TR011a - Fire Products Collectors - 1 MW Square	ID: 2670 Revision: 3
Authority: Technical Leader	Page: 13 of 28
Original maintained by Quality Programs; copies are uncontrolled.	

## Heat Release Rate

The oxygen consumption heat release rate is calculated according to [1]:

$$HRR = C \left[ E\phi - (E_{CO} - E) \frac{1-\phi}{2} \frac{X_{CO}}{X_{O_2}} \right] \left( \frac{\dot{m}}{1+\phi(\alpha-1)} \right) \left( \frac{MW_{O_2}}{MW_{air}} \right) (1 - X_{H_2O}^0) X_{O_2}^0 \quad (2)$$

The oxygen depletion factor,  $\phi$ , in Equation 2 is a function of two co-dependent pairs: the concentrations of oxygen and carbon dioxide in the incoming air and in the product stream ( $X_{O_2}, X_{O_2}^0$ ) ( $X_{CO_2}, X_{CO_2}^0$ ). It has been shown that, under these circumstances, the approach to properly account for the uncertainty is to re-write Equation 2 in terms of the raw inputs [18]. Based on this, Equation (2) was broken down into thirty three components and a standard uncertainty was determined for each. Table 4 shows a list of the components along with a brief description.

**Table 4: Components used in the oxygen consumption HRR calculation**

Component	Description (Units in parentheses)
$A_{O_2}$	Current output from oxygen analyzer (A)
$A_{O_2,zero}$	Current output from oxygen analyzer flowing zero gas (A)
$A_{O_2,span}$	Current output from oxygen analyzer flowing span gas (A)
$A_{O_2,base}$	Current output from oxygen analyzer during pre-test baseline (A)
$X_{O_2,zero}$	Mole fraction of oxygen in zero gas (A)
$X_{O_2,span}$	Mole fraction of oxygen in span gas (A)
$A_{CO_2}$	Current output from carbon dioxide analyzer (A)
$A_{CO_2,zero}$	Current output from carbon dioxide analyzer flowing zero gas (A)
$A_{CO_2,span}$	Current output from carbon dioxide analyzer flowing span gas (A)
$A_{CO_2,base}$	Current output from carbon dioxide analyzer during pre-test baseline (A)
$X_{CO_2,zero}$	Mole fraction of carbon dioxide in zero gas (A)
$X_{CO_2,span}$	Mole fraction of carbon dioxide in span gas (A)
$A_{CO}$	Current output from carbon monoxide analyzer (A)
$A_{CO,zero}$	Current output from carbon monoxide analyzer flowing zero gas (A)
$A_{CO,span}$	Current output from carbon monoxide analyzer flowing span gas (A)
$X_{CO,zero}$	Mole fraction of carbon monoxide in zero gas (A)
$X_{CO,span}$	Mole fraction of carbon monoxide in span gas (A)
$M_{air,dry}$	Molecular weight of dry air (g/mol)
$M_{H_2O}$	Molecular weight of water (g/mol)
$M_{O_2}$	Molecular weight of oxygen (g/mol)
$E$	Net heat release of natural gas per kg of oxygen consumed (kJ/kg)



ATF-LS-FRL-TR011a - Fire Products Collectors - 1 MW Square	ID: 2670 Revision: 3
Authority: Technical Leader	Page: 14 of 28
Original maintained by Quality Programs; copies are uncontrolled.	

Component	Description (Units in parentheses)
$E_{CO}$	Net heat release of carbon monoxide per kg of oxygen consumed (kJ/kg)
$\alpha$	Volumetric expansion factor (--)
RH	Relative humidity of incoming air (%)
$P_{amb}$	Ambient pressure (Pa)
$T_{amb}$	Ambient temperature (K)
$C_{bdp}$	Bi-directional probe constant (--)
$f$	Velocity flow shape factor (--)
D	Duct diameter (m)
$T_1$	Duct temperature at the sampling location (K)
$T_2$	Duct temperature at the sampling location (K)
$A_{dp,meas}$	Current output from the pressure transducer (A)
$A_{dp,zero}$	Current output from the pressure transducer during pre-test baseline (A)

Variables and constants are grouped in Table 4 according to four primary categories: gas species concentrations, physical constants, ambient conditions and mass flow rate. A discussion of the uncertainty analysis for each category is given below.

#### Gas Species Concentration

ASTM E 2536 identifies three sources of error that should be considered in the estimation of uncertainty for oxygen measurements in a cone calorimeter: the data acquisition system, random (Type A) scatter in the data signal, and calibration [23]. Instrumentation used in the cone calorimeter is similar to what is used in large scale calorimeter hoods such as the 1 MW FPC. Based on this, these three sources of error were considered for the gas species uncertainty evaluation ( $O_2$ ,  $CO_2$  and  $CO$ ) performed here. A fourth source, calibration gas error, was added based on discussions with the instrument retailer [24].

Table 4 lists two components that contribute to gas species measurements: the unscaled analyzer signal ( $A_i$ ) and the mole fractions in the calibration gases ( $X_i$ ). The following sections provide details related to the uncertainty estimate for each component.

#### Analyzer Signal Uncertainty

The uncertainty estimate in the recorded analyzer signal included contributions from the data acquisition hardware and fluctuations in the data. The contribution from data acquisition hardware came from manufacturer's specifications. The uncertainty contribution associated with data fluctuations came from a statistical analysis of the raw signal collected in a calibration burner experiment.

The Servomex gas analyzer used in the 1 MW Square FPC sends an analog 4 – 20 mA signal to an Allen Bradley (AB) SLC 500 series programmable logic controller (PLC) through a 1746 NI16I 16 bit I/O module. Specifications for the AB hardware include a digital resolution of 640 nA and a calibrated accuracy of better than 0.15 % of range [25].



ATF-LS-FRL-TR011a - Fire Products Collectors - 1 MW Square	ID: 2670 Revision: 3
Authority: Technical Leader	Page: 15 of 28
Original maintained by Quality Programs; copies are uncontrolled.	

The standard uncertainty associated with fluctuations in the analyzer signal was estimated using the sample standard deviation. Calculations were performed using data recorded when the analyzer output was steady. Analyzer signals listed in Table 4 are divided into two categories: calibration ( $A_{i,zero}$ ,  $A_{i,span}$ ) and experiment ( $A_i$ ,  $A_{i,base}$ ). For the calibration signal uncertainty, the sample standard deviation was calculated over one minute periods during an 'AUTOCAL' cycle. For the experiment signal uncertainty the sample standard deviation was calculated during a calibration burner experiment. Statistics were performed for data spanning several minutes.

The combined uncertainty was calculated by combining the data acquisition and statistical components.

#### *Calibration Gas Uncertainty*

The 1 MW Square FPC is equipped with a modified Servomex Xentra 4100 gas analyzer that contains individual cells to measure each of the three species concentrations. Oxygen concentration is measured in a paramagnetic cell with 0 – 25 % range; CO<sub>2</sub> and CO are measured in non-dispersive infrared (NDIR) cells with peak concentration ranges of 10 % and 1 %, respectively. Each cell is calibrated using zero and span gases. The zero gas and CO / CO<sub>2</sub> span gas come with certifications from the supplier. The oxygen analyzer is spanned with ambient air; the uncertainty estimate for ambient O<sub>2</sub> concentration was taken from the literature [18].

The zero gas is "Zero" grade (99.99 %) nitrogen. Assuming a rectangular distribution, the standard uncertainty is +/- 5.8 x 10<sup>-5</sup>. The CO/CO<sub>2</sub> span gas is a Primary Standard grade mixture with certified accuracy of 1% for CO and 0.02 % for CO<sub>2</sub>. The concentrations of CO and CO<sub>2</sub> in the span gas are nominally 0.8 % and 8 %, respectively, with the balance comprised of N<sub>2</sub>. Assuming a rectangular distribution, the standard uncertainties of CO<sub>2</sub> and CO in the span gas are estimated to be 1.2 x 10<sup>-4</sup> and 4.6 x 10<sup>-5</sup>, respectively. Laboratory air is used to span the oxygen analyzer; the concentration is taken as 20.95 %. The estimated uncertainty associated with the oxygen span concentration is estimated to be 0.05 % [18]. This estimate was verified through a comparison with a high purity certified O<sub>2</sub>/N<sub>2</sub> mixture.

#### *Physical Constants*

Physical constants include the molecular weights of oxygen ( $M_{O_2}$ ), dry air ( $M_{air,dry}$ ) and water ( $M_{H_2O}$ ), in addition to the volumetric expansion factor ( $\alpha$ ) and the net heat release per unit mass of oxygen consumed for natural gas ( $E$ ) and carbon monoxide ( $E_{CO}$ ). The standard uncertainty of the molecular weights was taken as zero. The standard uncertainties of the remaining constants were based on previous work and summarized in Table 5 [18].



ATF-LS-FRL-TR011a - Fire Products Collectors - 1 MW Square	ID: 2670 Revision: 3
Authority: Technical Leader	Page: 16 of 28
Original maintained by Quality Programs; copies are uncontrolled.	

**Table 5: Summary of uncertainty in physical constants**

Parameter	Value	Standard Uncertainty
$\alpha$ (--)	1.104	0.048
$E$ (kJ/kg O <sub>2</sub> )	12550	19.95
$E_{CO}$ (kJ/kg O <sub>2</sub> )	17690	10

Ambient Conditions

Ambient conditions are measured using a wall mounted weather station that is permanently housed in the MBR. The weather station measures relative humidity, temperature and absolute pressure. Additional information, including the uncertainty analysis for each of the measured quantities, can be found in the laboratory instruction [28]. Table 6 shows a summary of the standard uncertainty for the ambient temperature, pressure and relative humidity.

**Table 6: Ambient conditions uncertainty summary**

Quantity	Standard Uncertainty
T <sub>a</sub> (°C)	0.6
P <sub>a</sub> (Pa)	115.5
RH (%)	2.2

Mass Flow Rate

The mass flow rate is expressed as:

$$\dot{m} = \rho \dot{V} \quad (3)$$

where  $\rho$  is the gas density (kg/m<sup>3</sup>) and  $\dot{V}$  is the volumetric flow rate (m<sup>3</sup>/s). The density was expressed in terms of temperature using the ideal gas law:

$$\rho = \rho_{std} \frac{T_{std}}{T} \quad (4)$$

where the standard condition is taken as 300 K and 1 atm. The volumetric flow rate was calculated using:

$$\dot{V} = f A V \quad (5)$$

where  $f$  is the flow shape factor,  $A$  is the duct area (m<sup>2</sup>) and  $V$  is the velocity (m/s). The flow shape factor was calculated using data from flow traverse measurements conducted previously [29]. The duct area is a function of the diameter,  $D$  (0.65 m). The velocity was calculated according to [6]:



ATF-LS-FRL-TR011a - Fire Products Collectors - 1 MW Square	ID: 2670 Revision: 3
Authority: Technical Leader	Page: 17 of 28
Original maintained by Quality Programs; copies are uncontrolled.	

$$V = \sqrt{\frac{2 \Delta P T}{\rho_{std} T_{std}}} / C_{bdp} \quad (6)$$

where  $\Delta P$  is the differential pressure measured by the velocity probe (Pa) and  $T$  (K) is the temperature inside the duct.  $C_{bdp}$  is the bi-directional probe factor that has been shown to be a constant ( $1.08 \pm 5\%$ ) over the range of Reynolds numbers encountered in the duct flow [8]. Combining the above equations and substituting ( $T_{std} = 300\text{ K}$ ,  $\rho_{std} = 1.18\text{ kg/m}^3$ ) yields:

$$\dot{m} = \frac{20.875 D^2 f}{C_{bdp}} \sqrt{\frac{\Delta P}{T}} \quad (7)$$

The temperature was taken as the average of two independent measurements at each time step and the differential pressure was expressed as:

$$\begin{aligned} \Delta P &= \Delta P_{meas} - \Delta P_{baseline} \\ &= (m_{dp} A_{dp} + b_{dp})_{meas} - (m_{dp} A_{dp} + b_{dp})_{baseline} \end{aligned} \quad (8)$$

where  $m_{dp}$  and  $b_{dp}$  are the calibration factors for the differential pressure transducer. The differential pressure is corrected by subtracting a baseline value, which is measured in a separate experiment with the transducer cross-ported. Consolidating terms, the differential pressure can be expressed as:

$$\Delta P = m_{dp} (A_{dp,meas} - A_{dp,baseline}) \quad (9)$$

The calibration constant,  $m_{dp}$ , for the pressure transducer was 38920.1 Pa/A. This yields the expression for mass flow rate:

$$\dot{m} = \frac{4118.26 D^2 f}{C_{bdp}} \sqrt{\frac{A_{dp,meas} - A_{dp,baseline}}{T}} \quad (10)$$

The standard uncertainty in the diameter measurement was calculated from the standard deviation of five independent measurements. The result was  $D = 0.653 \pm 0.001\text{ m}$ . To account for the duct not being perfectly circular this uncertainty was increased to  $\pm 0.005\text{ m}$ . The standard uncertainty in the flow shape factor ( $f$ ) was estimated based on the standard error in the least squares regression from the traverse data [29]. The standard uncertainty in the temperature ( $\pm 1.6\text{ K}$ ) was taken from the literature [18].



ATF-LS-FRL-TR011a - Fire Products Collectors - 1 MW Square	ID: 2670 Revision: 3
Authority: Technical Leader	Page: 18 of 28
Original maintained by Quality Programs; copies are uncontrolled.	

The combined standard uncertainty in the pressure transducer data was calculated based on manufacturer’s specifications for the data acquisition hardware and pressure transducer, in addition to a statistical analysis of the signal. The data acquisition hardware is the same as what is used for the gas analyzers; the standard uncertainty is  $7.1 \times 10^{-8}$  A. The standard uncertainty for a Setra model 267 pressure transducer is a function of the input range for the instrument; for a device with input range  $\Delta P = 0 - 0.62$  kPa ( $0 - 2.5$  inch H<sub>2</sub>O) the standard uncertainty is  $5.2 \times 10^{-5}$  A [9]. The uncertainty associated with data fluctuation in the transducer output was calculated from the sample standard deviation collected during a calibration burner experiment. Table 7 shows a summary of the combined standard uncertainty for the pressure measurement for three fire sizes and a baseline.

**Table 7: Combined standard uncertainty in the differential pressure measurement.**

Fire Size	Combined Standard Uncertainty (A)
Baseline	$5.2 \times 10^{-5}$
50 KW	$1.2 \times 10^{-4}$
520 kW	$1.6 \times 10^{-4}$
1055 kW	$1.8 \times 10^{-4}$

Summary

Table 8 shows a summary of the uncertainty in the oxygen consumption heat release rate performed for three fire sizes. The first column lists the 33 components (with units in parentheses) that comprise the oxygen consumption HRR calculation, as described in Table 4. For each component, the nominal value obtained for a 520 kW fire is listed in column 2. Column 3 lists the standard uncertainty for each component that was discussed in the preceding sections. Columns 4 – 6 list the sensitivity coefficients calculated for fire sizes of 50 kW, 520 kW and 1055 kW.



ATF-LS-FRL-TR011a - Fire Products Collectors - 1 MW Square	ID: 2670 Revision: 3
Authority: Technical Leader	Page: 19 of 28
Original maintained by Quality Programs; copies are uncontrolled.	

**Table 8: Summary of HRR uncertainty calculations**

Variable / Parameter $x_i$	Nominal Value	Standard Uncertainty $u(x_i)$	Sensitivity Coefficient $ s_j $		
			50 kW	520 kW	1055 kW
$A_{O_2}$	0.01681	$8.2 \times 10^{-6}$	$1.1 \times 10^6$	$9.8 \times 10^5$	$1.1 \times 10^6$
$A_{O_2,zero}$	0.00400	$6.2 \times 10^{-7}$	$4.3 \times 10^3$	$4.3 \times 10^4$	$8.6 \times 10^4$
$A_{O_2,span}$	0.01741	$1.8 \times 10^{-6}$	$4.9 \times 10^3$	$4.9 \times 10^4$	$9.8 \times 10^4$
$A_{O_2,base}$	0.01739	$1.3 \times 10^{-6}$	$1.1 \times 10^6$	$9.9 \times 10^5$	$1.1 \times 10^6$
$X_{O_2,zero}$	0.00000	$5.8 \times 10^{-5}$	$2.7 \times 10^2$	$2.7 \times 10^3$	$5.5 \times 10^3$
$X_{O_2,span}$	0.20950	$5.0 \times 10^{-4}$	$3.2 \times 10^2$	$3.1 \times 10^3$	$6.2 \times 10^3$
$A_{CO_2}$	0.00479	$1.0 \times 10^{-5}$	$9.3 \times 10^4$	$7.9 \times 10^4$	$8.3 \times 10^4$
$A_{CO_2,zero}$	0.00400	$2.3 \times 10^{-7}$	$4.6 \times 10^2$	$5.0 \times 10^3$	$9.9 \times 10^3$
$A_{CO_2,span}$	0.01680	$1.3 \times 10^{-6}$	$4.1 \times 10^2$	$4.5 \times 10^3$	$9.1 \times 10^3$
$A_{CO_2,base}$	0.00406	$9.7 \times 10^{-7}$	$9.3 \times 10^4$	$8.0 \times 10^4$	$8.4 \times 10^4$
$X_{CO_2,zero}$	0.00000	$5.8 \times 10^{-5}$	$7.4 \times 10^1$	$8.0 \times 10^2$	$1.6 \times 10^3$
$X_{CO_2,span}$	0.08000	$1.2 \times 10^{-4}$	$6.5 \times 10^1$	$7.2 \times 10^2$	$1.5 \times 10^3$
$A_{CO}$	0.00403	$2.9 \times 10^{-6}$	$1.7 \times 10^4$	$1.4 \times 10^4$	$1.5 \times 10^4$
$A_{CO,zero}$	0.00400	$1.4 \times 10^{-6}$	$1.7 \times 10^4$	$1.4 \times 10^4$	$1.5 \times 10^4$
$A_{CO,span}$	0.01680	$1.6 \times 10^{-5}$	$4.8 \times 10^0$	$3.6 \times 10^1$	$6.8 \times 10^1$
$X_{CO,zero}$	0.00000	$5.8 \times 10^{-5}$	$2.6 \times 10^4$	$2.3 \times 10^4$	$2.5 \times 10^4$
$X_{CO,span}$	0.00800	$4.6 \times 10^{-5}$	$7.6 \times 10^0$	$5.7 \times 10^1$	$1.1 \times 10^2$
$M_{air,dry}$ (g/mol)	28.97	0	0	0	0
$M_{H_2O}$ (g/mol)	18	0	0	0	0
$M_{O_2}$ (g/mol)	32	0	0	0	0
$E$ (kJ/kg)	12550	19.95	$4.2 \times 10^{-3}$	$4.2 \times 10^{-2}$	$8.4 \times 10^{-2}$
$E_{CO}$ (kJ/kg)	17690	10	$5.2 \times 10^{-6}$	$4.0 \times 10^{-5}$	$7.8 \times 10^{-5}$
$\alpha$ (--)	1.104	0.048	$2.3 \times 10^{-1}$	$2.5 \times 10^1$	$9.3 \times 10^1$
RH (%)	51.69	2.16	$9.2 \times 10^{-3}$	$1.1 \times 10^{-1}$	$2.2 \times 10^{-1}$
$P_{amb}$ (Pa)	101107	115.5	$1.3 \times 10^{-6}$	$5.6 \times 10^{-5}$	$1.1 \times 10^{-4}$
$T_{amb}$ (K)	298.95	0.59	$7.9 \times 10^{-3}$	$3.4 \times 10^{-1}$	$6.9 \times 10^{-1}$
$C_{bdp}$	1.08	0.054	$4.6 \times 10^1$	$4.6 \times 10^2$	$9.3 \times 10^2$
$f$ (--)		$7.6 \times 10^{-3}$	$4.8 \times 10^1$	$4.8 \times 10^2$	$9.7 \times 10^2$
D (m)	0.653	0.005	$1.6 \times 10^2$	$1.6 \times 10^3$	$3.2 \times 10^3$
$T_1$ (K)	401.88	1.6	$4.3 \times 10^{-2}$	$3.2 \times 10^{-1}$	$5.4 \times 10^{-1}$
$T_2$ (K)	401.30	1.6	$4.3 \times 10^{-2}$	$3.2 \times 10^{-1}$	$5.4 \times 10^{-1}$
$A_{dp,meas}$ (A)	0.00648	$1.6 \times 10^{-4}$	$1.1 \times 10^4$	$1.0 \times 10^5$	$1.4 \times 10^5$
$A_{dp,zero}$ (A)	0.00400	$5.2 \times 10^{-5}$	$1.2 \times 10^4$	$1.1 \times 10^5$	$1.4 \times 10^5$



ATF-LS-FRL-TR011a - Fire Products Collectors - 1 MW Square	ID: 2670 Revision: 3
Authority: Technical Leader	Page: 20 of 28
Original maintained by Quality Programs; copies are uncontrolled.	

The combined standard uncertainty for each fire size was calculated by combining terms in Table 8 according to Equation 1. The results are summarized in Table 9; the values represent a coverage factor of  $k = 1$ . In the case of a normal distribution, this translates to a confidence level of approximately 68%. To obtain a higher confidence level a higher coverage factor can be applied. A coverage factor of  $k = 2$  in a normally distributed population provides a confidence level of approximately 95 %.

**Table 9: Combined standard uncertainty in the heat release rate**

Fire Size (kW)	Combined Standard Uncertainty (kW)	Relative Uncertainty (%)
50	4	7.6
520	33	6.3
1055	67	6.4

Table 10 shows a list of the variables that contribute most significantly to the combined uncertainty. The HRR is highly sensitive to the oxygen concentration measurements ( $A_{O_2}$ ,  $A_{O_2,base}$ ) as demonstrated by the large sensitivity factor shown for these variables in Table 8. At the fire size increases, the terms associated with the mass flow become more significant ( $C_{bdp}$ ,  $D$ ,  $A_{dp,meas}$ ). These terms account for more than 75 % of the combined uncertainty at 1055 kW, with the differential pressure probe factor ( $C_{bdp}$ ) being dominant.

**Table 10: Contribution to the combined uncertainty**

Variable / Parameter $x_i$	Fire Size		
	50 kW	520 kW	1055 kW
$A_{O_2}$ (A)	14.0	9.1	20.8
$A_{O_2,base}$ (A)	12.0	0.2	0.0
$X_{CO,zero}$ (--)	14.9	0.2	0.0
$C_{bdp}$ (--)	39.4	55.0	55.5
$D$ (m)	4.1	5.7	5.8
$A_{dp,meas}$ (A)	12.0	25.5	14.3

### Convective Heat Release Rate

The convective heat release rate (CHRR) is expressed as:

$$\dot{Q}_c = \dot{m} (h_2 - h_1) \quad (11)$$

where  $\dot{Q}_c$  is the convective heat release rate (kW),  $\dot{m}$  is the mass flow rate (kg/s) and  $h_1$  and  $h_2$  are the enthalpies of the incoming air and product stream, respectively (kJ/kg). The mass flow



ATF-LS-FRL-TR011a - Fire Products Collectors - 1 MW Square	ID: 2670 Revision: 3
Authority: Technical Leader	Page: 21 of 28
Original maintained by Quality Programs; copies are uncontrolled.	

rate is evaluated in the same manner as in the HRR calculation (Equation 11) and is a function of six quantities ( $A_{dp,meas}$ ,  $A_{dp,baseline}$ ,  $D$ ,  $T$ ,  $C_{bdp}$ ,  $f$ ). The standard uncertainty in each of these is the same as in the HRR analysis.

The enthalpy difference is calculated according to a polynomial fit evaluated over the temperature range:

$$h_2 - h_1 = \left( \alpha T + \beta \frac{T^2}{2} + \gamma \frac{T^3}{3} + \delta \frac{T^4}{4} + \varepsilon \frac{T^5}{5} \right) \Big|_{T_1}^{T_2} \quad (12)$$

where  $\alpha$ ,  $\beta$ ,  $\gamma$ ,  $\delta$ ,  $\varepsilon$  are fit parameters. Data used to fit the coefficients was taken from two sources [30, 31]. The error associated with the fit parameters is negligible; the uncertainty in enthalpy was assumed to be solely due to error in the temperature measurement<sup>1</sup>. The standard uncertainty in temperature is the same as in the HRR analysis. Table 11 shows a summary of the CHRR and the combined standard uncertainty in the CHRR for each corresponding HRR step; the values represent a coverage factor of  $k = 1$ .

**Table 11: Convective heat release rate uncertainty summary**

HRR (kW)	CHRR (kW)	Combined Uncertainty (kW)	Relative Uncertainty (%)
50	32	6	19
520	386	24	6.3
1055	791	45	5.7

### Gas Species Production

The gas species mass production rate is expressed as:

$$h_2 - h_1 = \left( \alpha T + \beta \frac{T^2}{2} + \gamma \frac{T^3}{3} + \delta \frac{T^4}{4} + \varepsilon \frac{T^5}{5} \right) \Big|_{T_1}^{T_2} \quad (12)$$

Where  $\dot{m}_x$  is the production rate of species  $x$  (kg/s),  $\dot{m}$  is the mass flow rate in the exhaust duct (kg/s),  $X_x$  and  $X_{x,base}$  are the mole fractions of species  $x$  in the product stream and the incoming air, respectively (mol/mol),  $M_x$  is the molecular weight of species  $x$  (g/mol) and  $M_a$  is the molecular weight of air (g/mol).

<sup>1</sup> The polynomial fit parameters used for the enthalpy calculation were those for air.



ATF-LS-FRL-TR011a - Fire Products Collectors - 1 MW Square	ID: 2670 Revision: 3
Authority: Technical Leader	Page: 22 of 28
Original maintained by Quality Programs; copies are uncontrolled.	

All variables in Equation (13) are evaluated in the same manner as in the HRR calculation (Equation 1). The mass flow rate is a function of six quantities ( $A_{dp,meas}$ ,  $A_{dp,baseline}$ ,  $D$ ,  $T$ ,  $C_{bdp}$ ,  $f$ ). The mole fractions are calculated from the analyzer current and calibration concentrations. The standard uncertainty in each of these is the same as in the HRR analysis.

Table 12 and Table 13 show summaries of the combined uncertainty in the CO<sub>2</sub> and CO production rates, respectively, for three fire sizes. The values represent a coverage factor of  $k = 1$ . Relative uncertainty levels in the CO production rate are high at low HRR mainly because of the low CO levels generated by natural gas fires.

**Table 12: Combined uncertainty in the CO<sub>2</sub> production rate**

HRR (kW)	$\dot{m}_{CO_2}$ (g/s)	Combined Uncertainty (g/s)	Relative Uncertainty (%)
50	2.2	0.1	6.6
520	26	1.6	6.3
1055	55	3.7	6.7

**Table 13: Combined uncertainty in the CO production rate**

HRR (kW)	$\dot{m}_{CO}$ (g/s)	Combined Uncertainty (g/s)	Relative Uncertainty (%)
50	0.01	0.01	94.3
520	0.07	0.01	13.9
1055	0.1	0.01	9.2

## Smoke Production

The rate of smoke release (RSR) is expressed as:

$$RSR = k\dot{V} \quad (14)$$

where  $k$  (m<sup>-1</sup>) is the optical extinction coefficient measured by the ODM and  $\dot{V}$  (m<sup>3</sup>/s) is the volumetric flow rate in the exhaust duct.

The standard uncertainty for the extinction coefficient is described in the ODM Technical Reference [15]. For the laser system the relative standard uncertainty is less than 1 % for  $k > 0.1$  m<sup>-1</sup>; for  $k > 0.2$  m<sup>-1</sup> the relative uncertainty is less than 0.5 %.

Uncertainty in the volumetric flow rate was calculated in a manner similar to the procedure used for the mass flow rate in the HRR analysis. The volumetric flow rate is a function of the same six quantities as the mass flow rate ( $A_{dp,meas}$ ,  $A_{dp,baseline}$ ,  $D$ ,  $T$ ,  $C_{bdp}$ ,  $f$ ).



ATF-LS-FRL-TR011a - Fire Products Collectors - 1 MW Square	ID: 2670 Revision: 3
Authority: Technical Leader	Page: 23 of 28
Original maintained by Quality Programs; copies are uncontrolled.	

Smoke data was collected from an experiment in which corrugated cardboard was the primary fuel. The peak HRR in this experiment was approximately 300 kW; at this fire size the extinction coefficient measured by the laser ODM was  $0.63 \text{ m}^{-1}$ , yielding a smoke release rate of  $2.7 \text{ m}^2/\text{s}$ . The combined standard uncertainty in the RSR under these conditions was  $0.14 \text{ m}^2/\text{s}$  or 5.5 %.

## References

1. ATF FRL Laboratory Instruction, Fire Products Collectors, ATF-LS-FRL-LI011.
2. ATF FRL Technical Reference, Servomex 4100 Gas Purity Analyzers, ATF-LS-FRL-TR016a.
3. "Automatic Gas Analysis Console & Ducting User's Manual," Fire Testing Technology Limited, Issue 4.1, January 2003.
4. "Xentra Analyzer Installation Manual," Servomex, Ref 0400/005C/2.
5. "SERVPRO 4100 Series Analyzer Supplementary Manual," Servomex, Part Number 04100007C, Revision 1.
6. ATF FRL Laboratory Instruction, Velocity – Differential Pressure, ATF-LS-FRL-LI009.
7. "Installation Guide Model 267 and 267MR Differential Pressure Transducers," Setra, Boxborough, MA, 2002.
8. McCaffrey, B. J., and Heskestad, G., "A Robust Bidirectional Low-Velocity Probe for Flame and Fire Applications," Combustion and Flame, 26, 125 – 127, 1976.
9. ATF FRL Technical Reference, Differential Pressure – Point Velocity Probes, ATF-LS-FRL-TR009a.
10. "VOLU-Probe/SS Stainless Steel Pitot Airflow Traverse Probes," AMC Power, Santa Rosa, CA 2007.
11. "Installation Procedure VOLU-Probe/1SS for Round Ducts," Air Monitor Corporation, Santa Rosa, CA.
12. ATF FRL Technical Reference, Differential Pressure – Averaging Velocity Probes, ATF-LS-FRL-TR009b.
13. ATF FRL Laboratory Instruction, Thermocouple, ATF-LS-FRL-LI001.
14. ATF FRL Laboratory Instruction, Optical Density Meter, ATF-LS-FRL-LI014.
15. ATF FRL Technical Reference, Optical Density Meter Fire Products Collector, ATF-LS-FRL-TR014a.
16. ATF FRL Laboratory Instruction, Calibration Burners, ATF-LS-FRL-LI010.
17. ATF FRL Technical Reference, Calibration Burners – Sand Burners, ATF-LS-FRL-TR010a.



ATF-LS-FRL-TR011a - Fire Products Collectors - 1 MW Square	ID: 2670 Revision: 3
Authority: Technical Leader	Page: 24 of 28
Original maintained by Quality Programs; copies are uncontrolled.	

18. Bryant, A.R., Ohlemiller, T.J., Johnsson, E.L, Hamins, A., Grove, B.S., Guthrie, W.F., Maranghides, A., Mulholland, G.W., “Special Publication 1007,” National Institute of Standards and Technology, Gaithersburg, Maryland, 2003.
19. Taylor, B. N., & Kuyatt, C. E., “NIST Technical Note 1297: Guidelines for Evaluating and Expressing the Uncertainty of NIST Measurement Results,” National Institute of Standards and Technology, Gaithersburg, Maryland, 1993.
20. Guthrie, W. & Liu, H., “Hands-on Workshop on Estimating and Reporting Measurement Uncertainty,” National Institute of Standards and Technology, Gaithersburg, Maryland, Presentation given to the Consumer Product Safety Commission (CPSC), 2007.
21. Babrauskas, V., Grayson, S. ed., *Heat Release in Fires*, E & FN Spon, London, 1992.
22. Kragten, J., “Calculating Standard Deviations and Confidence Intervals with a Universally Applicable Spreadsheet Technique”, *Analyst*, Vol. 119, pp 2161 – 2165, October, 1994.
23. ASTM E2536-09, *Standard Guide for Assessment of Measurement Uncertainty in Fire Tests*, ASTM International, West Conshohocken, Pennsylvania, 2010.
24. Email correspondence from Tim Banham, Test, Service & Support Coordinator, Fire Testing Technology Limited, to Paul Fuss, Fire Research Engineer, ATF Fire Research Laboratory, September 8, 2011.
25. *Allen-Bradley SLC 500™ Analog Input Modules, Catalog Numbers 1746-NI16I and 1746-NI16V – User Manual*, Rockwell Automation, December 1999.
26. Email correspondence from Dr. Sean Gregory, Product Manager, Fire Testing Technology Limited, to Scott Dillon, Fire Research Engineer, ATF Fire research Laboratory, January 15, 2003.
27. Email correspondence from Dr. Sean Gregory, Product Manager, Fire Testing Technology Limited, to Scott Dillon, Fire Research Engineer, ATF Fire research Laboratory, January 17, 2003.
28. ATF FRL Laboratory Instruction, Laboratory Conditions, ATF-LS-FRL-LI017.
29. Fire Research Laboratory Large Scale Calorimeter Velocity Traverses, ATFFRL-FR-070001
30. “Tables of Thermal Properties of Gases”, NBS Circular 564, 1955.
31. Kyle, B. G., “Chemical and Process Thermodynamics”, Englewood Cliffs / Prentice Hall, 1984.



ATF-LS-FRL-TR011a - Fire Products Collectors - 1 MW Square	ID: 2670 Revision: 3
Authority: Technical Leader	Page: 25 of 28
Original maintained by Quality Programs; copies are uncontrolled.	

## Appendix A – Experimental Data

Figure 9 shows heat release rate data from a calibration burner experiment conducted under the 1 MW Square FPC using gas train “C” and a 20 cm square burner [17]. Gas train “C” has a maximum flow rate of 100 SLPM, which for natural gas translates to a peak fire size of approximately 57 kW. The calibration burner was run through a series of 5-minute duration steps with outputs of 0, 2, 5, 10, 15, 25 and 50 kW. Data from the burner is labeled “Theoretical HRR” in the chart. Calculated HRR from FPC measurements is plotted on the same chart.

Average HRR values were calculated for the burner and FPC during each of the seven steps; the average values are plotted together in Figure 10. This chart shows the average theoretical HRR plotted against the average FPC HRR calculated for each step in Figure 9. The slope of a linear fit through this data is the C-Factor [1].

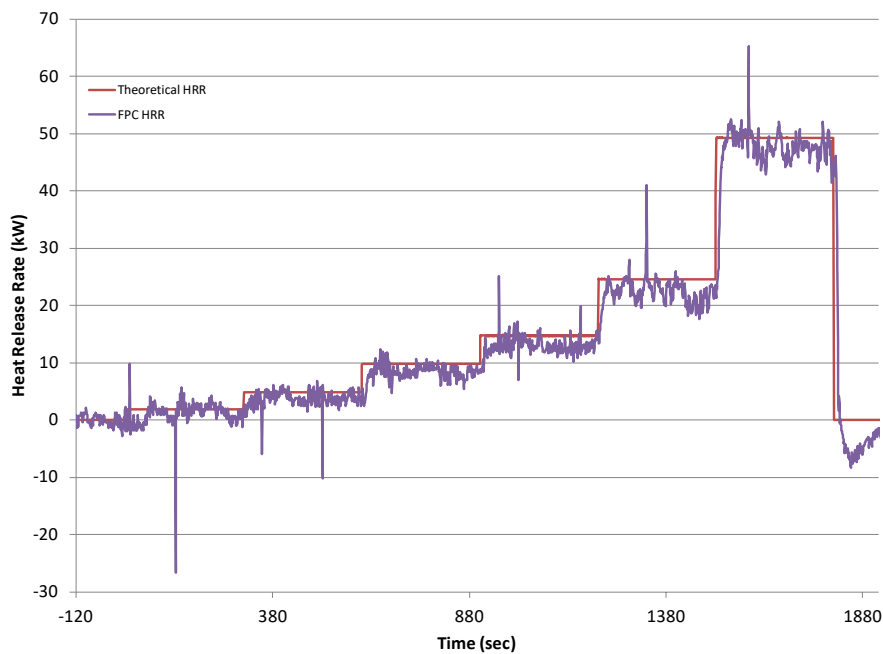

**Figure 9: Heat release rate data from a calibration burner experiment under the 1 MW Square FPC.**



ATF-LS-FRL-TR011a - Fire Products Collectors - 1 MW Square	ID: 2670 Revision: 3
Authority: Technical Leader	Page: 26 of 28
Original maintained by Quality Programs; copies are uncontrolled.	

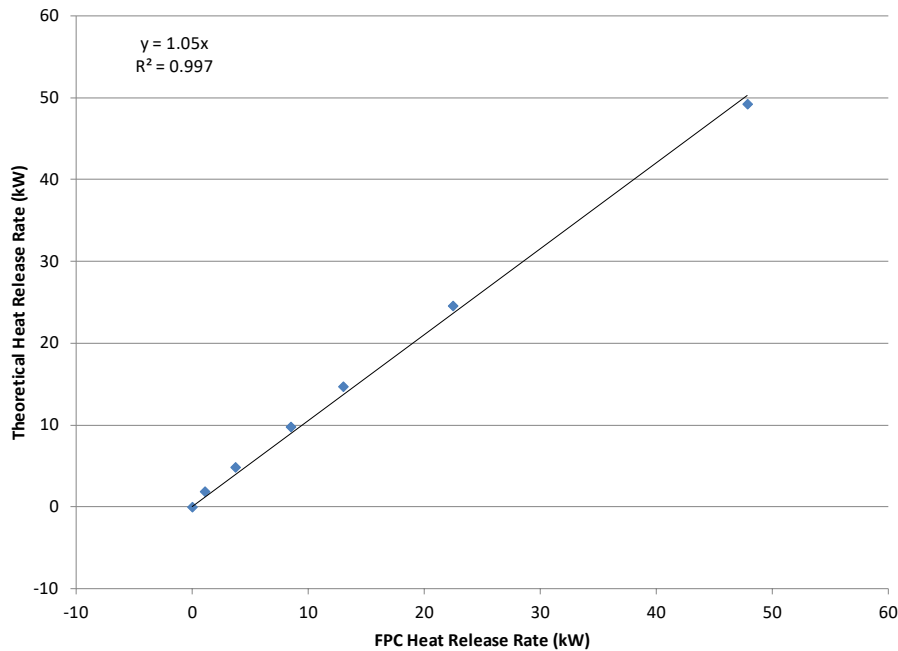

**Figure 10: Average theoretical HRR plotted against average FPC HRR for an experiment using gas train “C” and a 20 cm square calibration burner.**

Figure 11 shows heat release rate data from a calibration burner experiment conducted under the 1 MW Square FPC using gas trains “A” and “B” and a pair of 41 cm square burners [17]. Gas trains “A” and “B” each have a maximum flow rate of 1000 SLPM, which for natural gas translates to a peak fire size of approximately 570 kW. When run simultaneously they can produce a peak fire size of approximately 1100 kW. The calibration burners were run through a series of 5-minute duration steps with combined outputs of 0, 25, 50, 100, 300, 500, 700, 900 and 1100 kW. Data from the burners is labeled “Theoretical HRR” in the chart. Calculated HRR from FPC measurements is plotted on the same chart.

Average HRR values were calculated for the burners and FPC during each of the nine steps; the average values are plotted together in Figure 12. This chart shows the average theoretical HRR plotted against the average FPC HRR calculated for each step in Figure 11. The slope of a linear fit through this data is the C-Factor [1].

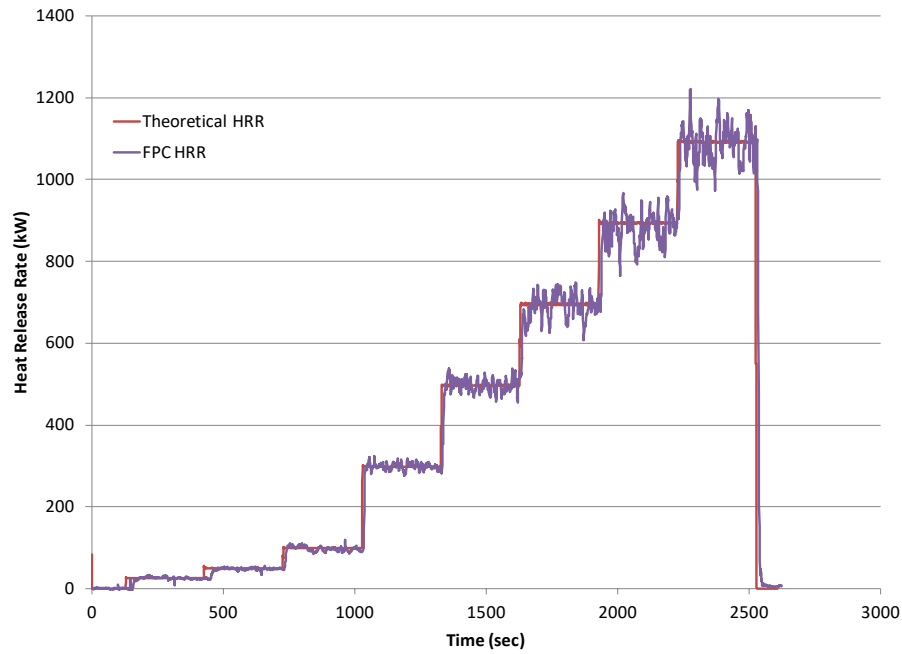

**Figure 11: Heat release rate data from a calibration burner experiment under the 1 MW Square FPC.**

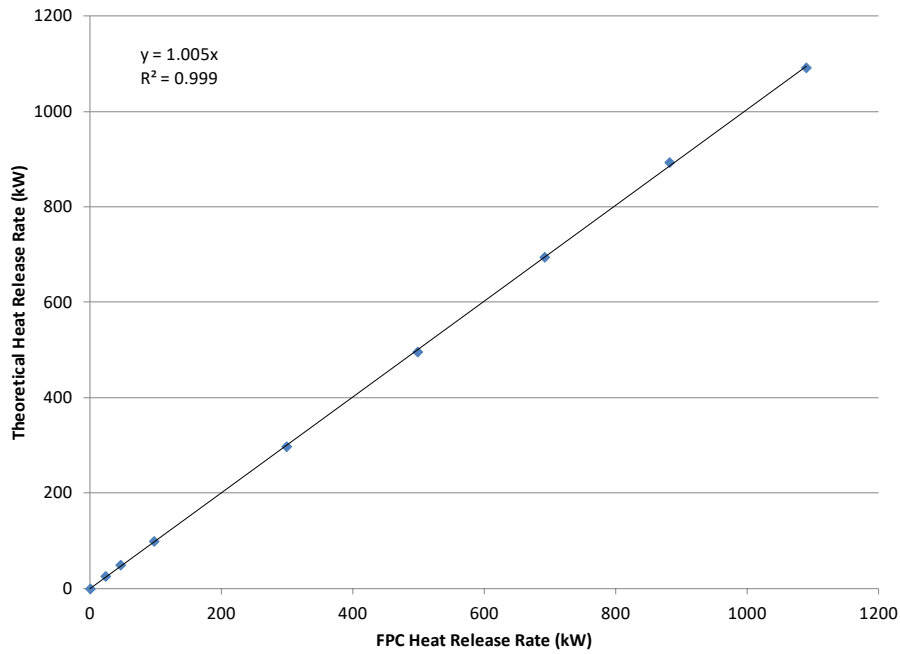

**Figure 12: Average theoretical HRR plotted against average FPC HRR for an experiment using gas trains “A” and “B” and a pair of 41 cm square calibration burners.**



ATF-LS-FRL-TR011b - Fire Products Collectors - 1 MW Round	ID: 5686 Revision: 3
Authority: Technical Leader	Page: 1 of 29
Original maintained by Quality Programs; copies are uncontrolled.	

## Scope

This Technical Reference covers the use, design and specifications of the 1 MW Round Fire Products Collector (FPC) in the Bureau of Alcohol, Tobacco, Firearms and Explosives (ATF) Fire Research Laboratory (FRL).

## Instrument Description

### *General*

The 1 MW Round FPC collects smoke and other products of combustion generated during fire experiments. A FPC consists of a collection hood connected to an exhaust duct, with air drawn through the duct by one or more variable speed fans. A FPC serves two purposes:

- 1) To remove combustion products from a laboratory space, and
- 2) To optimize the flow field for measurement and quantitative analyses of the combustion products.

A FPC provides four primary quantities: heat release rate (HRR), convective heat release rate (CHRR), gas species production and smoke production [1]. When used in conjunction with a weighing device, such as a load cell, the mass loss rate (MLR) of the burning object can be calculated. Gas species yields, smoke yield, and the effective heat of combustion of a burning item can then be calculated based on the MLR.

The 1 MW Round FPC is located in the southeast corner of the FRL's Medium Burn Room (MBR). Figure 1 shows a photograph of the collection hood and exhaust duct for the 1 MW Round FPC.

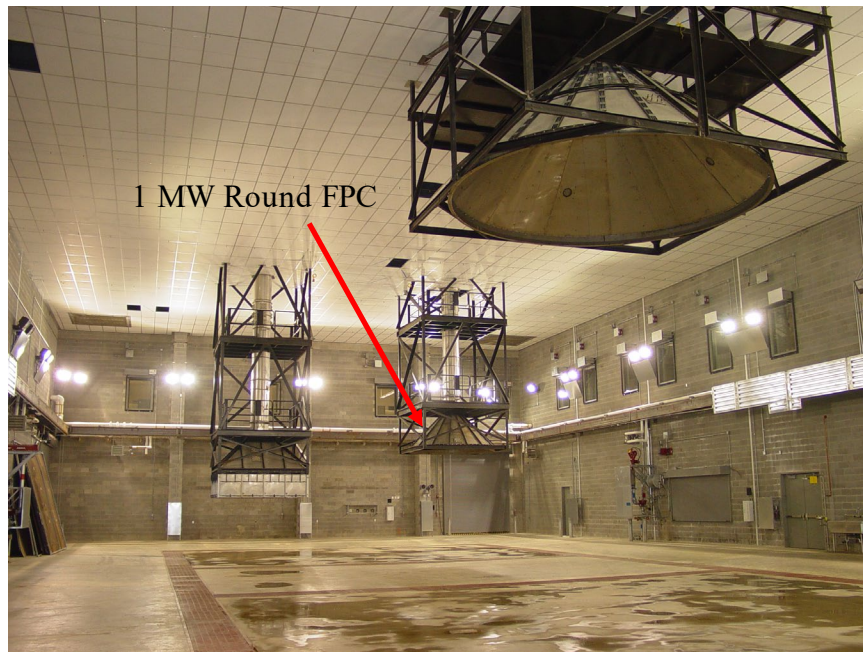

**Figure 1: 1 MW Round FPC**

## ***Hood and Collection System***

### **Physical Dimensions**

Figure 2 shows a plan view schematic of the 1 MW Round FPC collection hood in the MBR. The 3.3 m diameter collection hood and transitions to a circular exhaust duct with an internal diameter of 0.66 m. A 0.39 m diameter orifice plate is located near the entrance of the exhaust duct, approximately 6.0 m above the floor. The orifice enhances mixing of the fire products prior to reaching the instrumentation locations. The exhaust duct has a vertical run of approximately 10.9 m before transitioning to a horizontal run above the MBR ceiling. The base of the collection hood is 3.8 m above the MBR floor; however, skirts can be added to reduce the height to 2.8 m.

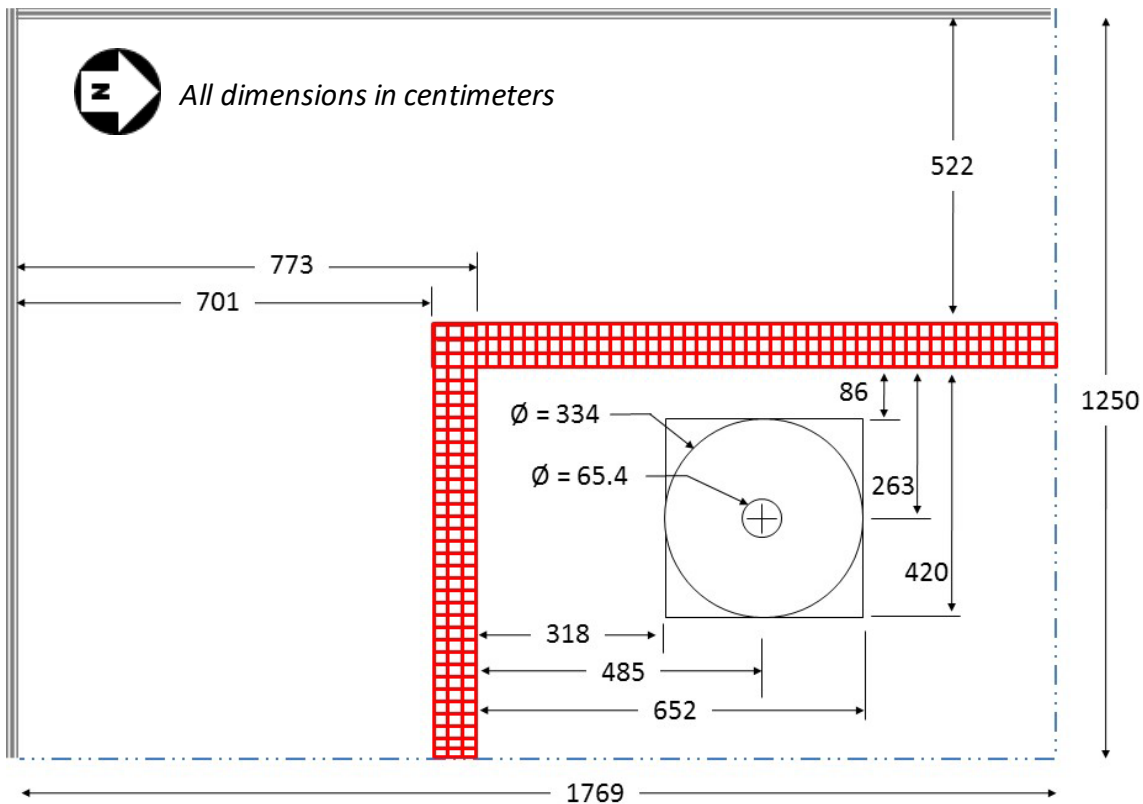

Figure 2: Plan view of 1 MW Round FPC in the MBR.

### Instrument Locations

Instruments are located at two levels in the FPC exhaust duct, as shown in Figure 3. The first instrument station is located approximately 3.5 m downstream of the inlet orifice. This station is located below the MBR ceiling and is accessible via a fixed platform. The first instrument station is used for flow measurement and gas sampling. The second instrument station is located approximately 5 m downstream of the first station, at the mezzanine level directly above the MBR. This station houses the laser and white light smoke measurement instruments.

### Flow Control

Flow in the FPC is controlled by a system of variable speed fans and actuated dampers that are programmed to maintain a fixed mass flow rate. The system is operated by a PC in the FRL Control Room. The FRL FPC's were designed to flow 6.8 kg/s (12,000 SCFM) per 1 MW heat release rate; this flow rate represents the approximate maximum capacity of the 1 MW Round FPC.

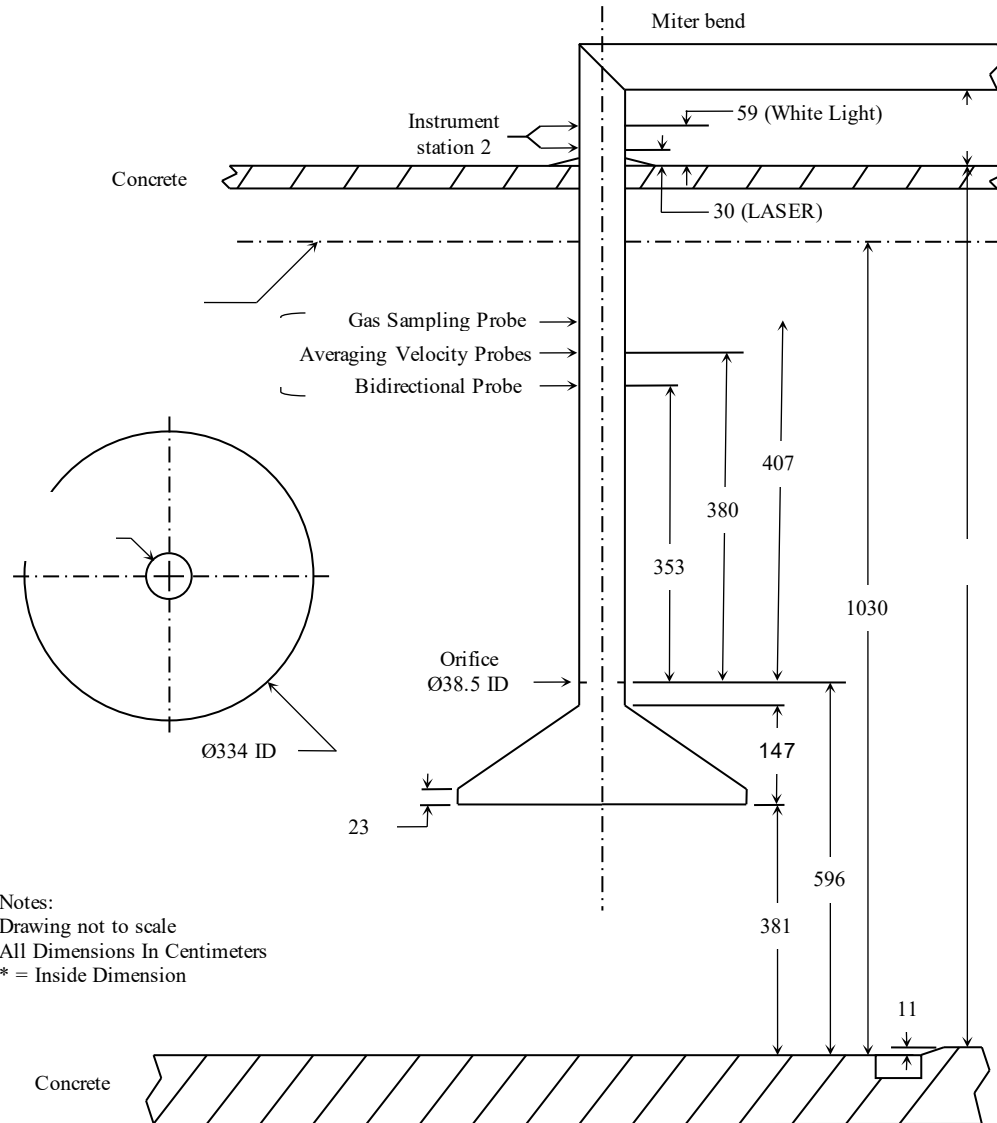

Notes:  
Drawing not to scale  
All Dimensions In Centimeters  
\* = Inside Dimension

Figure 3: Elevation view of 1 MW Round FPC in the MBR.



ATF-LS-FRL-TR011b - Fire Products Collectors - 1 MW Round	ID: 5686 Revision: 3
Authority: Technical Leader	Page: 5 of 29
Original maintained by Quality Programs; copies are uncontrolled.	

## ***Instrumentation***

The 1 MW Round FPC is equipped with instrumentation to measure gas species concentrations, temperature, velocity, and smoke concentration.

### **Gas Species Measurement**

The system of instrumentation used to measure gas species concentrations consists of a gas sampling probe located in the duct, tubing to transport the sample, a pump, sample conditioning equipment, and a gas analyzer.

Figure 4 shows a schematic of the gas sampling probe used in the 1 MW Round FPC. The gas sampling probe is a stainless steel tube with an outside diameter of 19.1 mm (0.75 inch) containing 30 sampling holes positioned at even intervals across the length of the probe. The sampling holes have diameters of either 3 mm or 4 mm and are spaced at 20 mm intervals. Figure 5 shows a detailed schematic of the gas sampling probe.

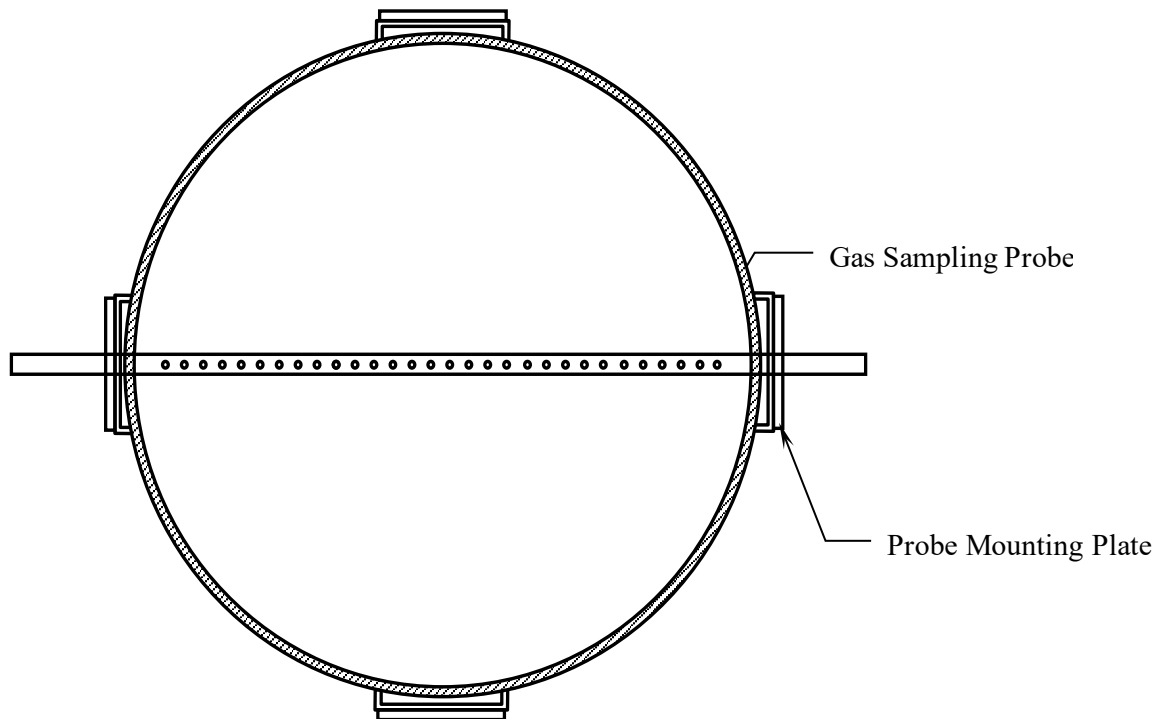

**Figure 4. Schematic of the gas sampling probe mounted in the duct**



ATF-LS-FRL-TR011b - Fire Products Collectors - 1 MW Round	ID: 5686 Revision: 3
Authority: Technical Leader	Page: 6 of 29
Original maintained by Quality Programs; copies are uncontrolled.	

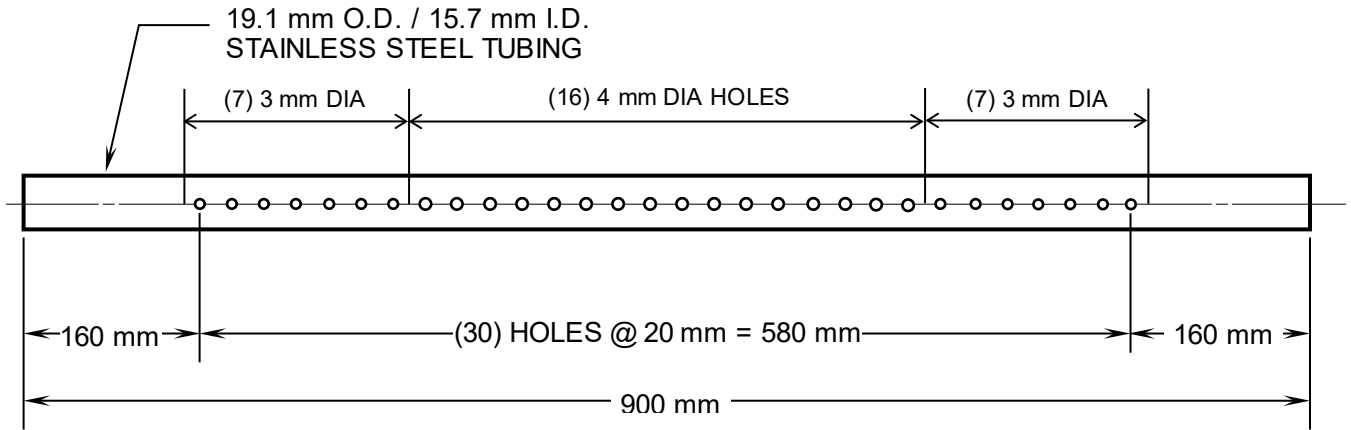

**Figure 5. Detailed schematic of the gas sampling probe showing hole locations**

The gas sampling probe is installed across the center of the exhaust duct with the sampling holes facing downstream. The probe is located 4.1 m downstream of the inlet orifice. The sample is drawn from both ends of the sampling probe and transported to the gas analysis rack through a single 9.5 mm (3/8 inch) diameter Teflon gas sampling line.

Tubing from the gas sampling probe is connected to a gas analysis rack constructed by Fire Testing Technology Limited (FTT), shown in Figure 6. This rack, located in a conditioned space on the mezzanine level above the MBR, includes a Servomex 4100 gas analyzer, gas train, pressure and flow control, filtering, and moisture removal.



ATF-LS-FRL-TR011b - Fire Products Collectors - 1 MW Round	ID: 5686 Revision: 3
Authority: Technical Leader	Page: 7 of 29
Original maintained by Quality Programs; copies are uncontrolled.	



**Figure 6: Photo of the 1 MW Round FPC gas analysis rack**

The gas analyzer is configured to measure oxygen, carbon monoxide and carbon dioxide. Table 1 lists the output range for these three gas species measured for the 1 MW FPC. Additional details on the gas analyzer rack are provided elsewhere [2 - 4].

A delay exists between the time that the gas sample is extracted from the duct and the time it reaches the analyzer. This delay time is determined by introducing a step-change in gas composition flowing past the gas sampling probe and monitoring the output of the analyzer for change in measured gas concentration. The delay time used in each experiment is documented in the FireTOSS datasheet. The gas analyzer was modified by Servomex to permit higher sample flow rates in order to reduce the sample delay times [4, 5].

**Table 1. Servomex 4100 gas species measurement ranges.**

Gas Species	Range
Oxygen (O <sub>2</sub> )	0 – 25 %
Carbon Dioxide (CO <sub>2</sub> )	0 – 10 %
Carbon Monoxide (CO)	0 – 1 %



ATF-LS-FRL-TR011b - Fire Products Collectors - 1 MW Round	ID: 5686 Revision: 3
Authority: Technical Leader	Page: 8 of 29
Original maintained by Quality Programs; copies are uncontrolled.	

## Flow Measurement

The flow of gases in the duct is measured using a pressure transducer, velocity probe, and thermocouple. Details on the use of differential pressure probes for velocity measurements are contained in the Laboratory Instruction [6].

### Pressure Transducer

A Setra model 267 pressure transducer with a range of 0 – 620 Pa (0 – 2.5 inches of water) and an output of 4 – 20 mA is used for differential pressure measurement in the 1 MW Round FPC [7]. The transducer is connected to the differential pressure probes through a valve that can be closed to facilitate baseline readings and probe purging.

### Velocity Probe

Velocity measurements in the 1 MW Round FPC are performed using a bi-directional probe [8]. Figure 7 shows a schematic of the probe. The probe consists of two ports: one facing upstream and the other downstream. The differential pressure measured between the two ports is used to calculate the velocity at the probe location. A flow shape factor is applied to calculate the average duct velocity. The probes are mounted to the exterior of the duct via a 19 cm diameter mounting plate. All components are constructed of stainless steel. Additional details on the use of differential pressure probes for velocity measurements are contained in the Laboratory Instruction [6] and Technical Reference [9].

The 1 MW Round FPC duct is equipped with additional velocity probes. A pair of VOLU-probe/1SS Stainless Steel Pitot Airflow Traverse Probes [10] is mounted approximately 30 cm downstream of the bi-directional probes, as shown in Figure 3. Figure 8 shows a schematic of the probe. The probe consists of two manifolds: one each for static and total pressure measurement. Each manifold has pressure ports spaced at equal area intervals, producing a pressure representing the instantaneous average across the duct. The probes are mounted to the exterior of the duct via a 15 cm x 15 cm mounting plate on one end, with the opposite end secured by a pin support. Two probes are mounted at a 90° angle, per manufacturer specifications [11]. All components are constructed of stainless steel. Additional details on the use of differential pressure probes for velocity measurements are contained in the Laboratory Instruction [6] and Technical Reference [12].

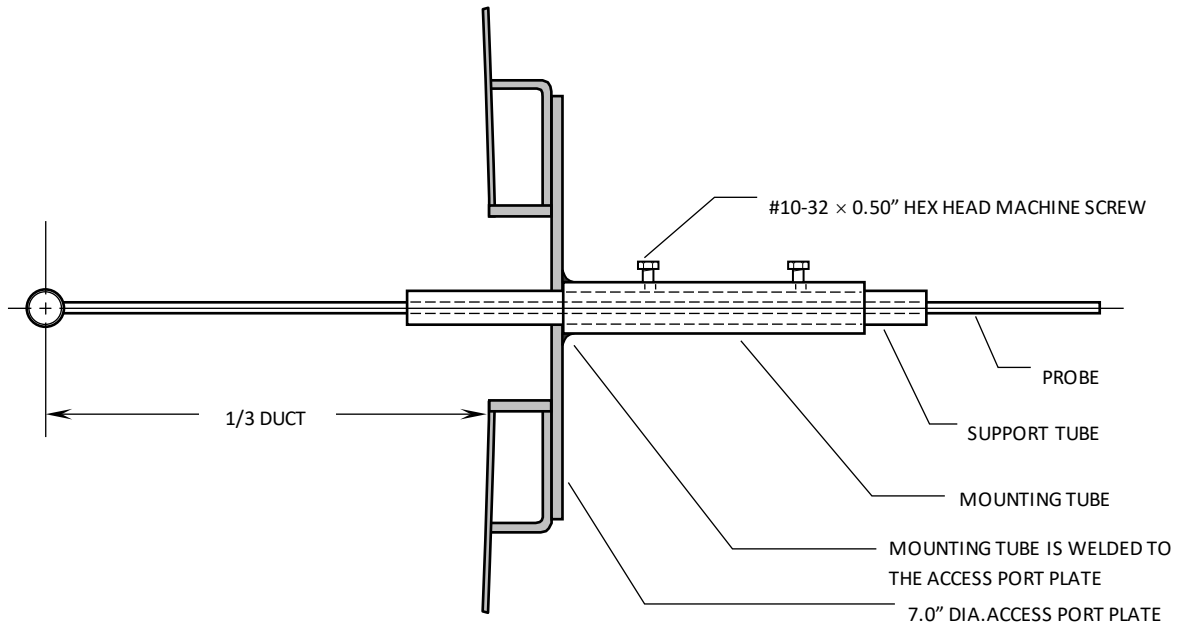

Figure 7: Schematic of the bi-directional probes.

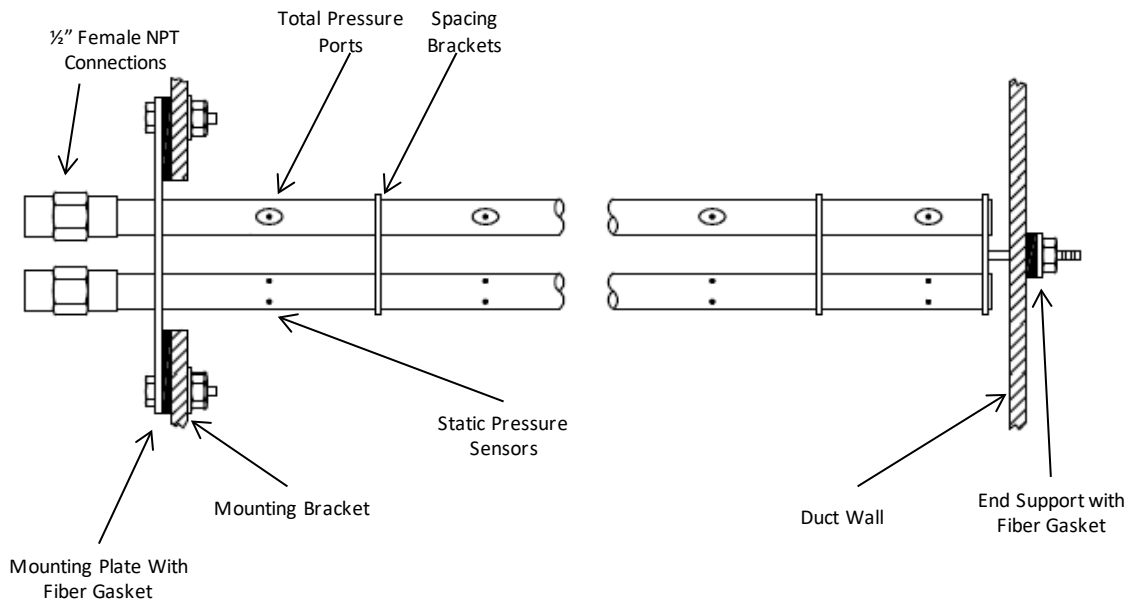

Figure 8: Schematic of the velocity traverse probes [10].



ATF-LS-FRL-TR011b - Fire Products Collectors - 1 MW Round	ID: 5686 Revision: 3
Authority: Technical Leader	Page: 10 of 29
Original maintained by Quality Programs; copies are uncontrolled.	

### Thermocouple

Two 1.5 mm (0.062 inch) Inconel-sheathed Type K special limits of error (SLE) thermocouples are used to monitor the gas temperature in the 1 MW FPC duct. Type K thermocouples have a peak temperature range of approximately 1250 °C (2282 °F). Type-K SLE thermocouple wire has a minimum accuracy of the greater of 1.1°C or 0.4% of the temperature reading over 0°C. Additional information on thermocouples can be found in the Laboratory Instruction [13].

### **Smoke Measurement**

Smoke is measured in the 1 MW Round FPC using optical density meters (ODMs) [14, 15]. Both laser and white-light ODMs are used in the 1 MW Round FPC. The ODM access ports are located approximately 5 m downstream of the velocity and gas sampling probes.

The laser ODM uses a low-power (0.5 mW) Helium-Neon (HeNe) laser that emits continuous light at 632 nm. The laser ODM uses two photodiode detectors; the main detector is used to measure the beam intensity as it is attenuated by the smoke and fire gases in the FPC. A compensating detector located near the laser head is used to account for changes in the laser output during a test so that these are not erroneously attributed to smoke attenuation by the main detector.

The white-light ODM, which is manufactured by Fire Testing Technology (FTT), uses a broad-band visible (white) light source. The light source consists of a halogen lamp and a series of lenses and apertures that combine to create a nearly collimated beam with a 25 mm diameter at the source. The light receiver uses a silicon photoelectric cell in front of which is a spectral filter to accommodate the human eye. The source and receiver are mounted to a rigid frame on opposite sides of the duct.



ATF-LS-FRL-TR011b - Fire Products Collectors - 1 MW Round	ID: 5686 Revision: 3
Authority: Technical Leader	Page: 11 of 29
Original maintained by Quality Programs; copies are uncontrolled.	

## **Data Acquisition**

Data acquisition for the 1 MW Round FPC is achieved using an Allen Bradley (AB) SLC 500 series Programmable Logic Controller (PLC). The system is equipped with a SLC 5/05 processor which has an IP address of 10.243.235.183. The FPC instrumentation and the corresponding FireTOSS tag are listed in Table 2. The PLC is located inside a cabinet on the east wall of a climate controlled instrument shed located on the mezzanine level, above the MBR. This shed houses the data acquisition and gas analysis instrumentation for all of the MBR FPCs.

**Table 2. Data Acquisition Setup**

<b>Devices Attached</b>	<b>Quantity Measured</b>	<b>FireTOSS Tag</b>
Laser ODM – Main	Light transmission	AB183_AI01_04
Laser ODM – Compensating	Light transmission	AB183_AI01_05
White Light ODM	Light transmission	AB183_AI01_06
Gas Analyzer – O <sub>2</sub>	Gas Concentration	AB183_AI03_12
Gas Analyzer – CO <sub>2</sub>	Gas Concentration	AB183_AI03_11 F
Gas Analyzer – CO	Gas Concentration	AB183_AI03_13
Pressure Transducer	Pressure	AB183_AI03_09 F
Thermocouple 1	Temperature	AB183_TC10_01
Thermocouple 2	Temperature	AB183_TC10_02

## **Measurement Range**

The practical HRR measurement range for the 1 MW Round FPC is from 10 kW to 1150 kW. This represents a range of HRR values over which the 1 MW FPC has a linear response. The minimum change in HRR that can be resolved with the 1 MW Round FPC is approximately 5 kW. Data from calibration experiments performed over the full measurement range of the FPC are shown in Appendix A.

## **Calibration**

A calibration burner [16] is used to determine the calibration factor, or C Factor, for a FPC. The type of calibration burner is selected based on the desired maximum HRR needed for the calibration. For the 1 MW Round FPC, sand burners [17] are used to determine the C Factor.

## **Calculations**

The calculations used to determine the HRR, and other output quantities, from the FPC are defined in the FPC Laboratory Instruction [1].



## Uncertainty and Accuracy

Fire Products Collectors are designed to provide four primary quantities: heat release rate (HRR), convective heat release rate (CHRR), gas species production and smoke production. The uncertainty associated with each of these quantities, calculated from measurements in the 1 MW Round FPC, was estimated using the guidelines of the National Institute of Standards and Technology (NIST) Special Publication 1007 [18], Technical Note 1297 [19], and the NIST Uncertainty Workshop [20]. The analysis outlined below is based primarily on data collected from natural gas fires generated using sand burners; the burner output was fixed for a period of five minutes at progressively increasing HRR levels [1, 17]. Uncertainty was calculated for nominal fire sizes of 100 kW, 500 kW and 1000 kW, representing low, middle and high ends of the operating range.

The combined standard uncertainty for a calculated output  $y$ , based on a number ( $i$ ) of uncorrelated input quantities  $x_i$ , is a combination of the uncertainty of each component. It is expressed mathematically by the following equation:

$$u_c(y) = k \sqrt{\sum s_i^2 u(x_i)^2} \quad (1)$$

where:

- $u_c(y)$  = Combined standard uncertainty in the output  $y$
- $u(x_i)$  = Standard uncertainty of each component  $x_i$
- $s_i$  = Sensitivity coefficient associated with each component ( $\partial/\partial x_i$ )
- $k$  = Coverage factor

The expression used to calculate the oxygen consumption HRR is a complex function of multiple variables and physical constants [1, 21]. The formulations used to calculate CHRR, gas species production and smoke production are considerably simpler and use many of the same measured input variables [1]. The approach taken in this analysis was to calculate the uncertainty in the HRR first. This necessitates calculating the standard uncertainty for most of the variables and parameters used in the other output quantities. A spreadsheet formulation was used to apply Equation (1) to perform the uncertainty calculations [22].

Table 3 summarizes the combined standard uncertainty for each output quantity of the 1 MW Round FPC. The HRR, CHRR, CO<sub>2</sub> and CO production rate values are based on data collected from the natural gas calibration burner experiments. Because the natural gas fires produce relatively little smoke, data for the rate of smoke release (RSR) are from separate experiments. The RSR data is from a gasoline pool fire with a peak HRR of approximately 465 kW. Details on how these uncertainty values were determined are provided in the sections that follow.



ATF-LS-FRL-TR011b - Fire Products Collectors - 1 MW Round	ID: 5686 Revision: 3
Authority: Technical Leader	Page: 13 of 29
Original maintained by Quality Programs; copies are uncontrolled.	

**Table 3. Uncertainty Summary**

Quantity	Calculated Value	Combined Standard Uncertainty	Relative Uncertainty
Heat Release Rate (HRR)	500 kW	32	6.4 %
Convective Heat Release Rate	382 kW	23	6.1 %
Mass Production Rate – CO <sub>2</sub>	25 g/s	1.5	6.2 %
Mass Production Rate – CO	0.05 g/s	0.01	15.5 %
Rate of Smoke Release – Laser	9.1 m <sup>2</sup> /s	0.58	6.3 %

### Heat Release Rate

The oxygen consumption heat release rate is calculated according to [1]:

$$HRR = C \left[ E\phi - (E_{CO} - E) \frac{1-\phi}{2} \frac{X_{CO}}{X_{O_2}} \right] \left( \frac{\dot{m}}{1+\phi(\alpha-1)} \right) \left( \frac{MW_{O_2}}{MW_{air}} \right) (1 - X_{H_2O}^0) X_{O_2}^0 \quad (2)$$

The oxygen depletion factor,  $\phi$ , in Equation 2 is a function of two co-dependent pairs: the concentrations of oxygen and carbon dioxide in the incoming air and in the product stream ( $X_{O_2}, X_{CO_2}^0$ ) ( $X_{CO_2}, X_{CO_2}^0$ ). It has been shown that, under these circumstances, the approach to properly account for the uncertainty is to re-write Equation 2 in terms of the raw inputs [18]. Based on this, Equation (2) was broken down into thirty three components and a standard uncertainty was determined for each. Table 4 shows a list of the components along with a brief description.

**Table 4: Components used in the oxygen consumption HRR calculation**

Component	Description (Units in parentheses)
$A_{O_2}$	Current output from oxygen analyzer (A)
$A_{O_2,zero}$	Current output from oxygen analyzer flowing zero gas (A)
$A_{O_2,span}$	Current output from oxygen analyzer flowing span gas (A)
$A_{O_2,base}$	Current output from oxygen analyzer during pre-test baseline (A)
$X_{O_2,zero}$	Mole fraction of oxygen in zero gas (A)
$X_{O_2,span}$	Mole fraction of oxygen in span gas (A)
$A_{CO_2}$	Current output from carbon dioxide analyzer (A)
$A_{CO_2,zero}$	Current output from carbon dioxide analyzer flowing zero gas (A)
$A_{CO_2,span}$	Current output from carbon dioxide analyzer flowing span gas (A)
$A_{CO_2,base}$	Current output from carbon dioxide analyzer during pre-test baseline (A)
$X_{CO_2,zero}$	Mole fraction of carbon dioxide in zero gas (A)
$X_{CO_2,span}$	Mole fraction of carbon dioxide in span gas (A)



ATF-LS-FRL-TR011b - Fire Products Collectors - 1 MW Round	ID: 5686 Revision: 3
Authority: Technical Leader	Page: 14 of 29
Original maintained by Quality Programs; copies are uncontrolled.	

Component	Description (Units in parentheses)
$A_{CO}$	Current output from carbon monoxide analyzer (A)
$A_{CO,zero}$	Current output from carbon monoxide analyzer flowing zero gas (A)
$A_{CO,span}$	Current output from carbon monoxide analyzer flowing span gas (A)
$X_{CO,zero}$	Mole fraction of carbon monoxide in zero gas (A)
$X_{CO,span}$	Mole fraction of carbon monoxide in span gas (A)
$M_{air,dry}$	Molecular weight of dry air (g/mol)
$M_{H_2O}$	Molecular weight of water (g/mol)
$M_{O_2}$	Molecular weight of oxygen (g/mol)
$E$	Net heat release of natural gas per kg of oxygen consumed (kJ/kg)
$E_{CO}$	Net heat release of carbon monoxide per kg of oxygen consumed (kJ/kg)
$\alpha$	Volumetric expansion factor (--)
RH	Relative humidity of incoming air (%)
$P_{amb}$	Ambient pressure (Pa)
$T_{amb}$	Ambient temperature (K)
$C_{bdp}$	Bi-directional probe constant (--)
$f$	Velocity flow shape factor (--)
D	Duct diameter (m)
$T_1$	Duct temperature at the sampling location (K)
$T_2$	Duct temperature at the sampling location (K)
$A_{dp,meas}$	Current output from the pressure transducer (A)
$A_{dp,zero}$	Current output from the pressure transducer during pre-test baseline (A)

Variables and constants are grouped in Table 4 according to four primary categories: gas species concentrations, physical constants, ambient conditions and mass flow rate. A discussion of the uncertainty analysis for each category is given below.

#### Gas Species Concentration

ASTM E 2536 identifies three sources of error that should be considered in the estimation of uncertainty for oxygen measurements in a cone calorimeter: the data acquisition system, random (Type A) scatter in the data signal, and calibration [23]. Instrumentation used in the cone calorimeter is similar to what is used in large scale calorimeter hoods such as the 1 MW FPC. Based on this, these three sources of error were considered for the gas species uncertainty evaluation ( $O_2$ ,  $CO_2$  and  $CO$ ) performed here. A fourth source, calibration gas error, was added based on discussions with the instrument retailer [24].

Table 4 lists two components that contribute to gas species measurements: the unscaled analyzer signal ( $A_i$ ) and the mole fractions in the calibration gases ( $X_i$ ). The following sections provide details related to the uncertainty estimate for each component.



ATF-LS-FRL-TR011b - Fire Products Collectors - 1 MW Round	ID: 5686 Revision: 3
Authority: Technical Leader	Page: 15 of 29
Original maintained by Quality Programs; copies are uncontrolled.	

### *Analyzer Signal Uncertainty*

The uncertainty estimate in the recorded analyzer signal included contributions from the data acquisition hardware and fluctuations in the data. The contribution from data acquisition hardware came from manufacturer's specifications. The uncertainty contribution associated with data fluctuations came from a statistical analysis of the raw signal collected in a calibration burner experiment.

The Servomex gas analyzer used in the 1 MW Round FPC sends an analog 4 – 20 mA signal to an Allen Bradley (AB) SLC 500 series programmable logic controller (PLC) through a 1746 NI16I 16 bit I/O module. Specifications for the AB hardware include a digital resolution of 640 nA and a calibrated accuracy of better than 0.15 % of range [25].

The standard uncertainty associated with fluctuations in the analyzer signal was estimated using the sample standard deviation. Calculations were performed using data recorded when the analyzer output was steady. Analyzer signals listed in Table 4 are divided into two categories: calibration ( $A_{i,zero}$ ,  $A_{i,span}$ ) and experiment ( $A_i$ ,  $A_{i,base}$ ). For the calibration signal uncertainty, the sample standard deviation was calculated over one minute periods during an 'AUTOCAL' cycle. For the experiment signal uncertainty, the sample standard deviation was calculated during a calibration burner experiment. Statistics were performed for data spanning several minutes.

The combined uncertainty was calculated by combining the data acquisition and statistical components.

### *Calibration Gas Uncertainty*

The 1 MW Round FPC is equipped with a modified Servomex 4100 gas analyzer that contains individual cells to measure each of the three species concentrations. Oxygen concentration is measured in a paramagnetic cell with 0 – 25 % range; CO<sub>2</sub> and CO are measured in non-dispersive infrared (NDIR) cells with peak concentration ranges of 10 % and 1 %, respectively. Each cell is calibrated using zero and span gases. The zero gas and CO / CO<sub>2</sub> span gas come with certifications from the supplier. The oxygen analyzer is spanned with ambient air; the uncertainty estimate for ambient O<sub>2</sub> concentration was taken from the literature [18].

The zero gas is "Zero" grade (99.99 %) nitrogen. Assuming a rectangular distribution, the standard uncertainty is  $\pm 5.8 \times 10^{-5}$ . The CO/CO<sub>2</sub> span gas is a Primary Standard grade mixture with certified accuracy of 1% for CO and 0.02 % for CO<sub>2</sub>. The concentrations of CO and CO<sub>2</sub> in the span gas are nominally 0.8 % and 8 %, respectively, with the balance comprised of N<sub>2</sub>. Assuming a rectangular distribution, the standard uncertainties of CO<sub>2</sub> and CO in the span gas are estimated to be  $1.2 \times 10^{-4}$  and  $4.6 \times 10^{-5}$ , respectively. Laboratory air is used to span the oxygen analyzer; the concentration is taken as 20.95 %. The estimated uncertainty associated with the oxygen span concentration is estimated to be 0.05 % [18]. This estimate was verified through a comparison with a high purity certified O<sub>2</sub>/N<sub>2</sub> mixture.



ATF-LS-FRL-TR011b - Fire Products Collectors - 1 MW Round	ID: 5686 Revision: 3
Authority: Technical Leader	Page: 16 of 29
Original maintained by Quality Programs; copies are uncontrolled.	

### Physical Constants

Physical constants include the molecular weights of oxygen ( $M_{O_2}$ ), dry air ( $M_{air,dry}$ ) and water ( $M_{H_2O}$ ), in addition to the volumetric expansion factor ( $\alpha$ ) and the net heat release per unit mass of oxygen consumed for natural gas ( $E$ ) and carbon monoxide ( $E_{CO}$ ). The standard uncertainty of the molecular weights was taken as zero. The standard uncertainties of the remaining constants were based on previous work and summarized in Table 5 [18].

**Table 5: Summary of uncertainty in physical constants**

Parameter	Value	Standard Uncertainty
$\alpha$ (--)	1.104	0.048
$E$ (kJ/kg O <sub>2</sub> )	12550	19.95
$E_{CO}$ (kJ/kg O <sub>2</sub> )	17690	10

### Ambient Conditions

Ambient conditions are measured using a wall mounted weather station that is permanently housed in the MBR. The weather station measures relative humidity, temperature and absolute pressure. Additional information, including the uncertainty analysis for each of the measured quantities, can be found in the laboratory instruction [26]. Table 6 shows a summary of the standard uncertainty for the ambient temperature, pressure and relative humidity.

**Table 6: Ambient conditions uncertainty summary**

Quantity	Standard Uncertainty	Quantity
Ta (°C)	0.6	Ta (°C)
Pa (Pa)	115.5	Pa (Pa)

### Mass Flow Rate

The mass flow rate is expressed as:

$$\dot{m} = \rho \dot{V} \quad (3)$$

where  $\rho$  is the gas density (kg/m<sup>3</sup>) and  $\dot{V}$  is the volumetric flow rate (m<sup>3</sup>/s). The density was expressed in terms of temperature using the ideal gas law:

$$\rho = \rho_{std} \frac{T_{std}}{T} \quad (4)$$

where the standard condition is taken as 300 K and 1 atm. The volumetric flow rate was calculated using:

$$\dot{V} = f A V \quad (5)$$



ATF-LS-FRL-TR011b - Fire Products Collectors - 1 MW Round	ID: 5686 Revision: 3
Authority: Technical Leader	Page: 17 of 29
Original maintained by Quality Programs; copies are uncontrolled.	

where  $f$  is the flow shape factor,  $A$  is the duct area ( $m^2$ ) and  $V$  is the velocity ( $m/s$ ). The flow shape factor was calculated using data from flow traverse measurements conducted previously [27]. The duct area is a function of the diameter,  $D$  (0.65 m). The velocity was calculated according to [6]:

$$V = \sqrt{\frac{2 \Delta P T}{\rho_{std} T_{std}}} / C_{bdp} \quad (6)$$

where  $\Delta P$  is the differential pressure measured by the velocity probe (Pa) and  $T$  (K) is the temperature inside the duct.  $C_{bdp}$  is the bi-directional probe factor that has been shown to be a constant ( $1.08 \pm 5\%$ ) over the range of Reynolds numbers encountered in the duct flow [8]. Combining the above equations and substituting ( $T_{std} = 300\text{ K}$ ,  $\rho_{std} = 1.18\text{ kg/m}^3$ ) yields:

$$\dot{m} = \frac{20.875 D^2 f}{C_{bdp}} \sqrt{\frac{\Delta P}{T}} \quad (7)$$

The temperature was taken as the average of two independent measurements at each time step and the differential pressure was expressed as:

$$\begin{aligned} \Delta P &= \Delta P_{meas} - \Delta P_{baseline} \\ &= (m_{dp} A_{dp} + b_{dp})_{meas} - (m_{dp} A_{dp} + b_{dp})_{baseline} \end{aligned} \quad (8)$$

where  $m_{dp}$  and  $b_{dp}$  are the calibration factors for the differential pressure transducer. The differential pressure is corrected by subtracting a baseline value, which is measured in a separate experiment with the transducer cross-ported. Consolidating terms, the differential pressure can be expressed as:

$$\Delta P = m_{dp} (A_{dp,meas} - A_{dp,baseline}) \quad (9)$$

The calibration constant,  $m_{dp}$ , for the pressure transducer was 38920.1 Pa/A. This yields the expression for mass flow rate:

$$\dot{m} = \frac{4118.26 D^2 f}{C_{bdp}} \sqrt{\frac{A_{dp,meas} - A_{dp,baseline}}{T}} \quad (10)$$

The standard uncertainty in the diameter measurement was calculated from the standard deviation of five independent measurements. The result was  $D = 0.654 \pm 0.003\text{ m}$ . To account for the duct not being perfectly circular this uncertainty was increased to  $\pm 0.005\text{ m}$ . The



ATF-LS-FRL-TR011b - Fire Products Collectors - 1 MW Round	ID: 5686 Revision: 3
Authority: Technical Leader	Page: 18 of 29
Original maintained by Quality Programs; copies are uncontrolled.	

standard uncertainty in the flow shape factor ( $f$ ) was estimated based on the standard error in the least squares regression from the traverse data [27]. The standard uncertainty in the temperature measurement ( $\pm 1.5$  K) was estimated by combining the fundamental error limit of the probe and the sample standard deviation of data calculated during a calibration burner experiment. The standard uncertainty in the average temperature was calculated by combining uncertainties in the individual measurements using Eqn. (1).

The combined standard uncertainty in the pressure transducer data was calculated based on manufacturer’s specifications for the data acquisition hardware and pressure transducer, in addition to a statistical analysis of the signal. The data acquisition hardware is the same as what is used for the gas analyzers; the standard uncertainty is  $7.1 \times 10^{-8}$  A. The standard uncertainty for a Setra model 267 pressure transducer is a function of the input range for the instrument; for a device with input range  $\Delta P = 0 - 0.62$  kPa (0 – 2.5 inch H<sub>2</sub>O) the standard uncertainty is  $5.2 \times 10^{-5}$  A [9]. The uncertainty associated with data fluctuation in the transducer output was calculated from the sample standard deviation collected during a calibration burner experiment. Table 7 shows a summary of the combined standard uncertainty for the pressure measurement for three fire sizes and a baseline.

**Table 7: Combined standard uncertainty in the differential pressure measurement.**

Fire Size	Combined Standard Uncertainty (A)
Baseline	$5.2 \times 10^{-5}$
95 KW	$1.0 \times 10^{-4}$
500 kW	$1.2 \times 10^{-4}$
1005 kW	$1.1 \times 10^{-4}$

Summary

Table 8 shows a summary of the uncertainty in the oxygen consumption heat release rate performed for three fire sizes. The first column lists the 33 components (with units in parentheses) that comprise the oxygen consumption HRR calculation, as described in Table 4. For each component, the nominal value obtained for a 500 kW fire is listed in column 2. Column 3 lists the standard uncertainty for each component that was discussed in the preceding sections. Columns 4 – 6 list the sensitivity coefficients calculated for fire sizes of 95 kW, 500 kW and 1005 kW.



ATF-LS-FRL-TR011b - Fire Products Collectors - 1 MW Round	ID: 5686 Revision: 3
Authority: Technical Leader	Page: 19 of 29
Original maintained by Quality Programs; copies are uncontrolled.	

**Table 8: Summary of HRR uncertainty calculations**

Variable / Parameter $x_i$	Nominal Value	Standard Uncertainty $u(x_i)$	Sensitivity Coefficient $ s_j $		
			95 kW	500 kW	1005 kW
$A_{O_2}$	0.01684	$1.2 \times 10^{-5}$	$9.2 \times 10^5$	$9.2 \times 10^5$	$1.1 \times 10^6$
$A_{O_2,zero}$	0.00400	$6.2 \times 10^{-7}$	$7.9 \times 10^3$	$4.1 \times 10^4$	$8.2 \times 10^4$
$A_{O_2,span}$	0.01741	$1.8 \times 10^{-6}$	$9.0 \times 10^3$	$4.7 \times 10^4$	$9.3 \times 10^4$
$A_{O_2,base}$	0.01743	$1.5 \times 10^{-6}$	$9.2 \times 10^5$	$9.2 \times 10^5$	$1.1 \times 10^6$
$X_{O_2,zero}$	0.00000	$5.8 \times 10^{-5}$	$5.1 \times 10^2$	$2.6 \times 10^3$	$5.3 \times 10^3$
$X_{O_2,span}$	0.20950	$5.0 \times 10^{-4}$	$5.7 \times 10^2$	$3.0 \times 10^3$	$6.0 \times 10^3$
$A_{CO_2}$	0.00482	$1.2 \times 10^{-5}$	$7.7 \times 10^4$	$7.4 \times 10^4$	$8.9 \times 10^4$
$A_{CO_2,zero}$	0.00400	$2.3 \times 10^{-7}$	$9.7 \times 10^2$	$4.8 \times 10^3$	$9.7 \times 10^3$
$A_{CO_2,span}$	0.01680	$1.3 \times 10^{-6}$	$8.8 \times 10^2$	$4.3 \times 10^3$	$8.9 \times 10^3$
$A_{CO_2,base}$	0.00407	$1.9 \times 10^{-6}$	$7.7 \times 10^4$	$7.5 \times 10^4$	$9.0 \times 10^4$
$X_{CO_2,zero}$	0.00000	$5.8 \times 10^{-5}$	$1.6 \times 10^2$	$7.6 \times 10^2$	$1.6 \times 10^3$
$X_{CO_2,span}$	0.08000	$1.2 \times 10^{-4}$	$1.4 \times 10^2$	$6.9 \times 10^2$	$1.4 \times 10^3$
$A_{CO}$	0.00403	$2.6 \times 10^{-6}$	$1.4 \times 10^4$	$1.3 \times 10^4$	$1.6 \times 10^4$
$A_{CO,zero}$	0.00400	$1.4 \times 10^{-6}$	$1.4 \times 10^4$	$1.3 \times 10^4$	$1.6 \times 10^4$
$A_{CO,span}$	0.01680	$1.6 \times 10^{-5}$	$1.2 \times 10^1$	$2.8 \times 10^1$	$7.8 \times 10^0$
$X_{CO,zero}$	0.00000	$5.8 \times 10^{-5}$	$2.2 \times 10^4$	$2.1 \times 10^4$	$2.6 \times 10^4$
$X_{CO,span}$	0.00800	$4.6 \times 10^{-5}$	$2.0 \times 10^1$	$4.5 \times 10^1$	$1.2 \times 10^2$
$M_{air,dry}$ (g/mol)	28.97	0	0	0	0
$M_{H_2O}$ (g/mol)	18	0	0	0	0
$M_{O_2}$ (g/mol)	32	0	0	0	0
$E$ (kJ/kg)	12550	19.95	$7.6 \times 10^{-3}$	$4.0 \times 10^{-2}$	$8.0 \times 10^{-2}$
$E_{CO}$ (kJ/kg)	17690	10	$1.3 \times 10^{-5}$	$3.2 \times 10^{-5}$	$8.9 \times 10^{-6}$
$\alpha$ (--)	1.104	0.048	$9.2 \times 10^{-1}$	$2.5 \times 10^1$	$8.0 \times 10^1$
RH (%)	52.2	2.16	$2.3 \times 10^{-2}$	$1.2 \times 10^{-1}$	$2.5 \times 10^{-1}$
$P_{amb}$ (Pa)	101636.2	115.5	$1.3 \times 10^{-5}$	$6.0 \times 10^{-5}$	$1.7 \times 10^{-4}$
$T_{amb}$ (K)	300.9	0.59	$7.7 \times 10^{-2}$	$3.7 \times 10^{-1}$	$1.0 \times 10^{-0}$
$C_{bdp}$	1.08	0.054	$8.4 \times 10^1$	$4.4 \times 10^2$	$8.9 \times 10^2$
$f$ (--)	1.0822	$1.7 \times 10^{-2}$	$8.7 \times 10^1$	$4.5 \times 10^2$	$9.1 \times 10^2$
D (m)	0.654	0.005	$2.9 \times 10^2$	$1.5 \times 10^3$	$3.1 \times 10^3$
$T_1$ (K)	409.7	1.5	$7.4 \times 10^{-2}$	$3.0 \times 10^{-1}$	$5.4 \times 10^{-1}$
$T_2$ (K)	409.2	1.5	$7.4 \times 10^{-2}$	$3.0 \times 10^{-1}$	$5.4 \times 10^{-1}$
$A_{dp,meas}$ (A)	0.00623	$1.2 \times 10^{-4}$	$2.8 \times 10^4$	$1.1 \times 10^5$	$1.3 \times 10^5$
$A_{dp,zero}$ (A)	0.00404	$5.2 \times 10^{-5}$	$2.9 \times 10^4$	$1.1 \times 10^5$	$1.3 \times 10^5$



ATF-LS-FRL-TR011b - Fire Products Collectors - 1 MW Round	ID: 5686 Revision: 3
Authority: Technical Leader	Page: 20 of 29
Original maintained by Quality Programs; copies are uncontrolled.	

The combined standard uncertainty for each fire size was calculated by combining terms in Table 8 according to Equation 1. The results are summarized in Table 9; the values represent a coverage factor of  $k = 1$ . In the case of a normal distribution, this translates to a confidence level of approximately 68%. To obtain a higher confidence level a higher coverage factor can be applied. A coverage factor of  $k = 2$  in a normally distributed population provides a confidence level of approximately 95 %.

**Table 9: Combined standard uncertainty in the heat release rate**

Fire Size (kW)	Combined Standard Uncertainty (kW)	Relative Uncertainty (%)
95	7	7.2
500	32	6.4
1005	64	6.4

Table 10 shows a list of the variables that contribute most significantly to the combined uncertainty. The HRR is highly sensitive to the oxygen concentration measurements ( $A_{O_2}$ ,  $A_{O_2,base}$ ) as demonstrated by the large sensitivity factor shown for these variables in Table 8. However, the mass flow terms ( $C_{bdp}$ ,  $D$ ,  $A_{dp,meas}$ ) contribute more to the combined uncertainty. These terms account for more than 70 % of the combined uncertainty, with the differential pressure probe factor ( $C_{bdp}$ ) being dominant.

**Table 10: Contribution to the combined uncertainty**

Variable / Parameter $x_i$	Fire Size		
	95 kW	500 kW	1005 kW
$A_{O_2}$ (A)	14.4	11.8	25.2
$A_{O_2,base}$ (A)	4.2	0.2	0.1
$X_{CO,zero}$ (--)	3.4	0.2	0.1
$C_{bdp}$ (--)	44.4	55.0	56.2
$D$ (m)	4.6	5.7	5.8
$A_{dp,meas}$ (A)	19.0	17.5	4.8
$A_{dp,zero}$ (A)	4.9	3.5	1.1
$f$ (--)	4.5	5.6	5.7



ATF-LS-FRL-TR011b - Fire Products Collectors - 1 MW Round	ID: 5686 Revision: 3
Authority: Technical Leader	Page: 21 of 29
Original maintained by Quality Programs; copies are uncontrolled.	

### Convective Heat Release Rate

The convective heat release rate (CHRR) is expressed as:

$$\dot{Q}_c = \dot{m} (h_2 - h_1) \tag{11}$$

where  $\dot{Q}_c$  is the convective heat release rate (kW),  $\dot{m}$  is the mass flow rate (kg/s) and  $h_1$  and  $h_2$  are the enthalpies of the incoming air and product stream, respectively (kJ/kg). The mass flow rate is evaluated in the same manner as in the HRR calculation (Equation 11) and is a function of six quantities ( $A_{dp, meas}$ ,  $A_{dp, baseline}$ ,  $D$ ,  $T$ ,  $C_{bdp}$ ,  $f$ ). The standard uncertainty in each of these is the same as in the HRR analysis.

The enthalpy difference is calculated according to a polynomial fit evaluated over the temperature range:

$$h_2 - h_1 = \left( \alpha T + \beta \frac{T^2}{2} + \gamma \frac{T^3}{3} + \delta \frac{T^4}{4} + \varepsilon \frac{T^5}{5} \right) \Big|_{T_1}^{T_2} \tag{12}$$

where  $\alpha$ ,  $\beta$ ,  $\gamma$ ,  $\delta$ ,  $\varepsilon$  are fit parameters. Data used to fit the coefficients was taken from two sources [28, 29]. The error associated with the fit parameters is negligible; the uncertainty in enthalpy was assumed to be solely due to error in the temperature measurement<sup>1</sup>. The standard uncertainty in temperature is the same as in the HRR analysis. Table 11 shows a summary of the CHRR and the combined standard uncertainty in the CHRR for each corresponding HRR step; the values represent a coverage factor of  $k = 1$ .

**Table 11: Convective heat release rate uncertainty summary**

HRR (kW)	CHRR (kW)	Combined Uncertainty (kW)	Relative Uncertainty (%)
95	68	5.5	8.1
500	382	23	6.1
1005	733	40	5.5

<sup>1</sup> The polynomial fit parameters used for the enthalpy calculation were those for air.



ATF-LS-FRL-TR011b - Fire Products Collectors - 1 MW Round	ID: 5686 Revision: 3
Authority: Technical Leader	Page: 22 of 29
Original maintained by Quality Programs; copies are uncontrolled.	

## Gas Species Production

The gas species mass production rate is expressed as:

$$\dot{m}_x = \dot{m} (X_x - X_{x,base}) \frac{M_x}{M_a} \quad (13)$$

Where  $\dot{m}_x$  is the production rate of species x (kg/s),  $\dot{m}$  is the mass flow rate in the exhaust duct (kg/s),  $X_x$  and  $X_{x,base}$  are the mole fractions of species x in the product stream and the incoming air, respectively (mol/mol),  $M_x$  is the molecular weight of species x (g/mol) and  $M_a$  is the molecular weight of air (g/mol).

All variables in Equation (13) are evaluated in the same manner as in the HRR calculation (Equation 1). The mass flow rate is a function of six quantities ( $A_{dp,meas}$ ,  $A_{dp,baseline}$ ,  $D$ ,  $T$ ,  $C_{bdp}$ ,  $f$ ). The mole fractions are calculated from the analyzer current and calibration concentrations. The standard uncertainty in each of these is the same as in the HRR analysis.

Table 12 and Table 13 show summaries of the combined uncertainty in the CO<sub>2</sub> and CO production rates, respectively, for three fire sizes. The values represent a coverage factor of  $k = 1$ . Relative uncertainty levels in the CO production rate are high at low HRR mainly because of the low CO levels generated by natural gas fires.

**Table 12: Combined uncertainty in the CO<sub>2</sub> production rate**

HRR (kW)	$\dot{m}_{CO_2}$ (g/s)	Combined Uncertainty (g/s)	Relative Uncertainty (%)
95	4.8	0.3	6.8
500	25	1.5	6.2
1005	53	3.2	6.0

**Table 13: Combined uncertainty in the CO production rate**

HRR (kW)	$\dot{m}_{CO}$ (g/s)	Combined Uncertainty (g/s)	Relative Uncertainty (%)
95	0.02	0.01	41.9
500	0.05	0.01	15.5
1005	0.13	0.01	9.0



## **Smoke Production**

The rate of smoke release (RSR) is expressed as:

$$RSR = k\dot{V} \quad (14)$$

where  $k$  ( $\text{m}^{-1}$ ) is the optical extinction coefficient measured by the ODM and  $\dot{V}$  ( $\text{m}^3/\text{s}$ ) is the volumetric flow rate in the exhaust duct.

The standard uncertainty for the extinction coefficient is described in the ODM Technical Reference [15]. For the laser system the relative standard uncertainty is less than 1 % for  $k > 0.1 \text{ m}^{-1}$ ; for  $k > 0.2 \text{ m}^{-1}$  the relative uncertainty is less than 0.5 %.

Uncertainty in the volumetric flow rate was calculated in a manner similar to the procedure used for the mass flow rate in the HRR analysis. The volumetric flow rate is a function of the same six quantities as the mass flow rate ( $A_{dp,meas}$ ,  $A_{dp,baseline}$ ,  $D$ ,  $T$ ,  $C_{bdp}$ ,  $f$ ).

Smoke data was collected from an experiment in which gasoline was the primary fuel. The peak HRR in this experiment was approximately 465 kW; at this fire size the extinction coefficient measured by the laser ODM was approximately  $2.3 \text{ m}^{-1}$ , yielding a smoke release rate of  $9.1 \text{ m}^2/\text{s}$ . The combined standard uncertainty in the RSR under these conditions was 0.58  $\text{m}^2/\text{s}$  or 6.3 %.



ATF-LS-FRL-TR011b - Fire Products Collectors - 1 MW Round	ID: 5686 Revision: 3
Authority: Technical Leader	Page: 24 of 29
Original maintained by Quality Programs; copies are uncontrolled.	

## References

1. ATF FRL Laboratory Instruction, Fire Products Collectors, ATF-LS-FRL-LI011.
2. ATF FRL Technical Reference, Servomex 4100 Gas Purity Analyzers, ATF-LS-FRL-TR016a.
3. “Automatic Gas Analysis Console & Ducting Users Manual,” Fire Testing Technology Limited, Issue 4.1, January 2003.
4. “Xentra Analyser Installation Manual,” Servomex, Ref 0400/005C/2.
5. “SERVPRO 4100 Series Analyser Supplementary Manual,” Servomex, Part Number 04100007C, Revision 1.
6. ATF FRL Laboratory Instruction, Velocity – Differential Pressure, ATF-LS-FRL-LI009.
7. “Installation Guide Model 267 and 267MR Differential Pressure Transducers,” Setra, Boxborough, MA, 2002.
8. McCaffrey, B. J., and Heskestad, G., “A Robust Bidirectional Low-Velocity Probe for Flame and Fire Applications,” Combustion and Flame, 26, 125 – 127, 1976.
9. ATF FRL Technical Reference, Differential Pressure – Point Velocity Probes, ATF-LS-FRL-TR009a.
10. “VOLU-Probe/SS Stainless Steel Pitot Airflow Traverse Probes,” AMC Power, Santa Rosa, CA 2007.
11. “Installation Procedure VOLU-Probe/ISS for Round Ducts,” Air Monitor Corporation, Santa Rosa, CA.
12. ATF FRL Technical Reference, Differential Pressure – Averaging Velocity Probes, ATF-LS-FRL-TR009b.
13. ATF FRL Laboratory Instruction, Thermocouple, ATF-LS-FRL-LI001.
14. ATF FRL Laboratory Instruction, Optical Density Meter, ATF-LS-FRL-LI014.
15. ATF FRL Technical Reference, Optical Density Meter Fire Products Collector, ATF-LS-FRL-TR014a.
16. ATF FRL Laboratory Instruction, Calibration Burners, ATF-LS-FRL-LI010.
17. ATF FRL Technical Reference, Calibration Burners – Sand Burners, ATF-LS-FRL-TR010a.
18. Bryant, A.R., Ohlemiller, T.J., Johnsson, E.L, Hamins, A., Grove, B.S., Guthrie, W.F., Maranghides, A., Mulholland, G.W., “Special Publication 1007,” National Institute of Standards and Technology, Gaithersburg, Maryland, 2003.



ATF-LS-FRL-TR011b - Fire Products Collectors - 1 MW Round	ID: 5686 Revision: 3
Authority: Technical Leader	Page: 25 of 29
Original maintained by Quality Programs; copies are uncontrolled.	

19. Taylor, B. N., & Kuyatt, C. E., "NIST Technical Note 1297: Guidelines for Evaluating and Expressing the Uncertainty of NIST Measurement Results," National Institute of Standards and Technology, Gaithersburg, Maryland, 1993.
20. Guthrie, W. & Liu, H., "Hands-on Workshop on Estimating and Reporting Measurement Uncertainty," National Institute of Standards and Technology, Gaithersburg, Maryland, Presentation given to the Consumer Product Safety Commission (CPSC), 2007.
21. Babrauskas, V., Grayson, S. ed., *Heat Release in Fires*, E & FN Spon, London, 1992.
22. Kragten, J., "Calculating Standard Deviations and Confidence Intervals with a Universally Applicable Spreadsheet Technique", *Analyst*, Vol. 119, pp 2161 – 2165, October, 1994.
23. ASTM E2536-09, *Standard Guide for Assessment of Measurement Uncertainty in Fire Tests*, ASTM International, West Conshohocken, Pennsylvania, 2010.
24. Email correspondence from Tim Banham, Test, Service & Support Coordinator, Fire Testing Technology Limited, to Paul Fuss, Fire Research Engineer, ATF Fire Research Laboratory, September 8, 2011.
25. *Allen-Bradley SLC 500™ Analog Input Modules, Catalog Numbers 1746-NI16I and 1746-NI16V – User Manual*, Rockwell Automation, December 1999.
26. ATF FRL Laboratory Instruction, Laboratory Conditions, ATF-LS-FRL-LI017.
27. Fire Research Laboratory Large Scale Calorimeter Velocity Traverses,
28. "Tables of Thermal Properties of Gases", NBS Circular 564, 1955.
29. Kyle, B. G., "Chemical and Process Thermodynamics", Englewood Cliffs / Prentice Hall, 1984.



ATF-LS-FRL-TR011b - Fire Products Collectors - 1 MW Round	ID: 5686 Revision: 3
Authority: Technical Leader	Page: 26 of 29
Original maintained by Quality Programs; copies are uncontrolled.	

## Appendix A – Experimental Data

Figure 9 shows heat release rate data from a calibration burner experiment conducted under the 1 MW Round FPC using gas train “C” and a 20 cm square burner [17]. Gas train “C” has a maximum flow rate of 100 SLPM, which for natural gas translates to a peak fire size of approximately 57 kW. The calibration burner was run through a series of 5-minute duration steps with outputs of 0, 5, 15, 30 and 50 kW. Data from the burner is labeled “Theoretical HRR” in the chart. Calculated HRR from FPC measurements is plotted on the same chart.

Average HRR values were calculated for the burner and FPC during each of the seven steps; the average values are plotted together in Figure 10. This chart shows the average theoretical HRR plotted against the average FPC HRR calculated for each step in Figure 9. The slope of a linear fit through this data is the C-Factor [1].

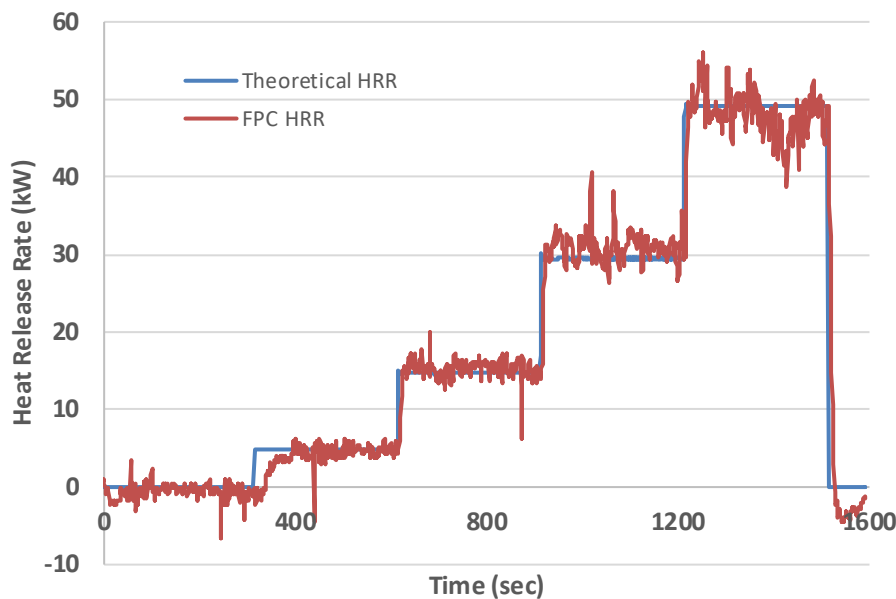

**Figure 9: Heat release rate data from a calibration burner experiment under the 1 MW Round FPC.**



ATF-LS-FRL-TR011b - Fire Products Collectors - 1 MW Round	ID: 5686 Revision: 3
Authority: Technical Leader	Page: 27 of 29
Original maintained by Quality Programs; copies are uncontrolled.	

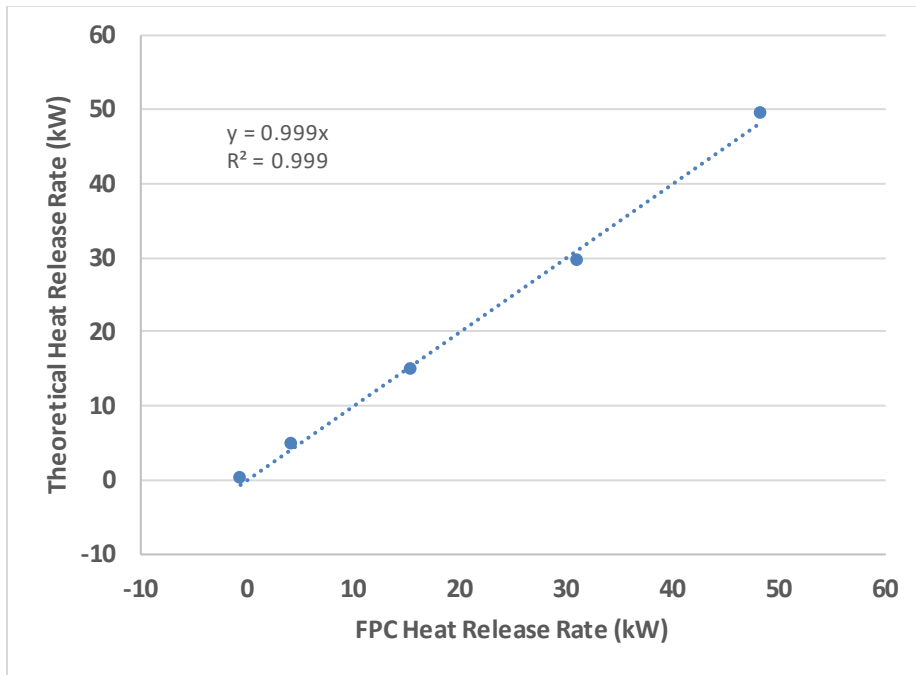

**Figure 10: Average theoretical HRR plotted against average FPC HRR for an experiment using gas train “C” and a 20 cm square calibration burner.**

Figure 11 shows heat release rate data from a calibration burner experiment conducted under the 1 MW Round FPC using gas trains “A” and “B” and a pair of 41 cm square burners [17]. Gas trains “A” and “B” each have a maximum flow rate of 1000 SLPM, which for natural gas translates to a peak fire size of approximately 570 kW. When run simultaneously they can produce a peak fire size of approximately 1100 kW. The calibration burners were run through a series of 5-minute duration steps with combined outputs of 0, 100, 300, 500, 700, 900 and 1100 kW. Data from the burners is labeled “Theoretical HRR” in the chart. Calculated HRR from FPC measurements is plotted on the same chart.

Average HRR values were calculated for the burners and FPC during each of the nine steps; the average values are plotted together in Figure 12. This chart shows the average theoretical HRR plotted against the average FPC HRR calculated for each step in Figure 11. The slope of a linear fit through this data is the C-Factor [1].

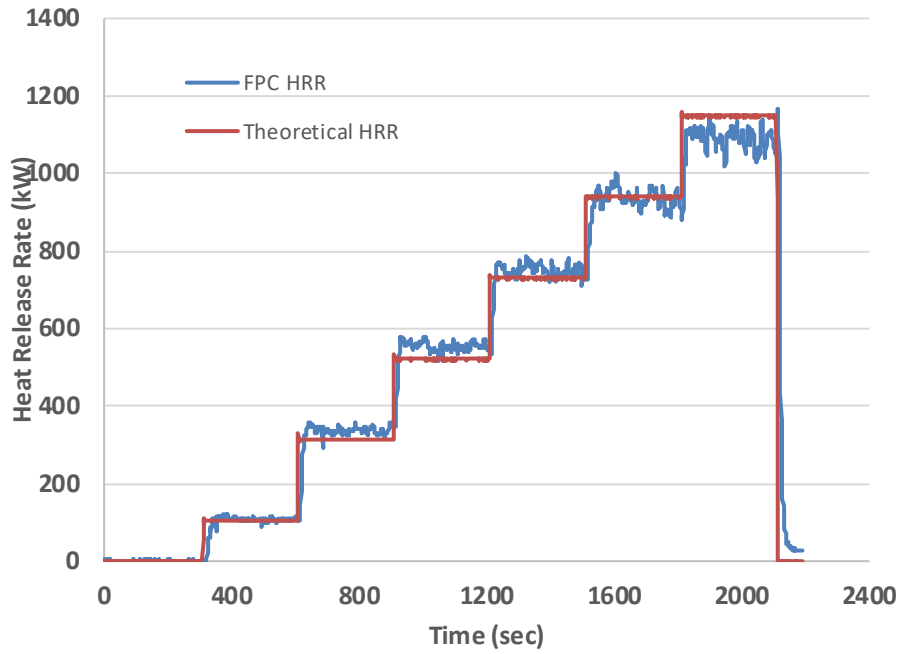

**Figure 11: Heat release rate data from a calibration burner experiment under the 1 MW Round FPC.**

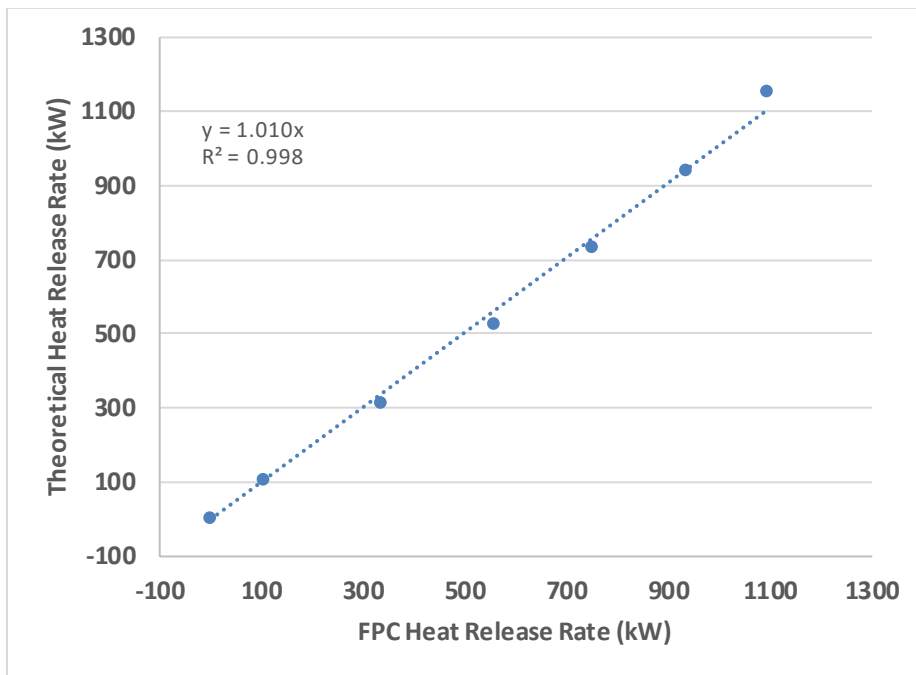

**Figure 12: Average theoretical HRR plotted against average FPC HRR for an experiment using gas trains “A” and “B” and a pair of 41 cm square calibration burners.**



ATF-LS-FRL-TR011c - Fire Products Collectors - 4 MW	ID: 5685 Revision: 2
Authority: Technical Leader	Page: 1 of 30
Original maintained by Quality Programs; copies are uncontrolled.	

## Scope

This Technical Reference covers the use, design and specifications of the 4 MW Fire Products Collector (FPC) in the Bureau of Alcohol, Tobacco, Firearms and Explosives (ATF) Fire Research Laboratory (FRL).

## Instrument Description

### *General*

The 4 MW FPC collects smoke and other products of combustion generated during fire experiments. A FPC consists of a collection hood connected to an exhaust duct, with air drawn through the duct by one or more variable speed fans. A FPC serves two purposes:

- 1) To remove combustion products from a laboratory space, and
- 2) To optimize the flow field for measurement and quantitative analyses of the combustion products.

A FPC provides four primary quantities: heat release rate (HRR), convective heat release rate (CHRR), gas species production and smoke production [1]. When used in conjunction with a weighing device, such as a load cell, the mass loss rate (MLR) of the burning object can be calculated. Gas species yields, smoke yield, and the effective heat of combustion of a burning item can then be calculated based on the MLR.

The 4 MW FPC is located in the north end of the FRL's Medium Burn Room (MBR). Figure 1 shows a photograph of the collection hood for the 4 MW FPC.

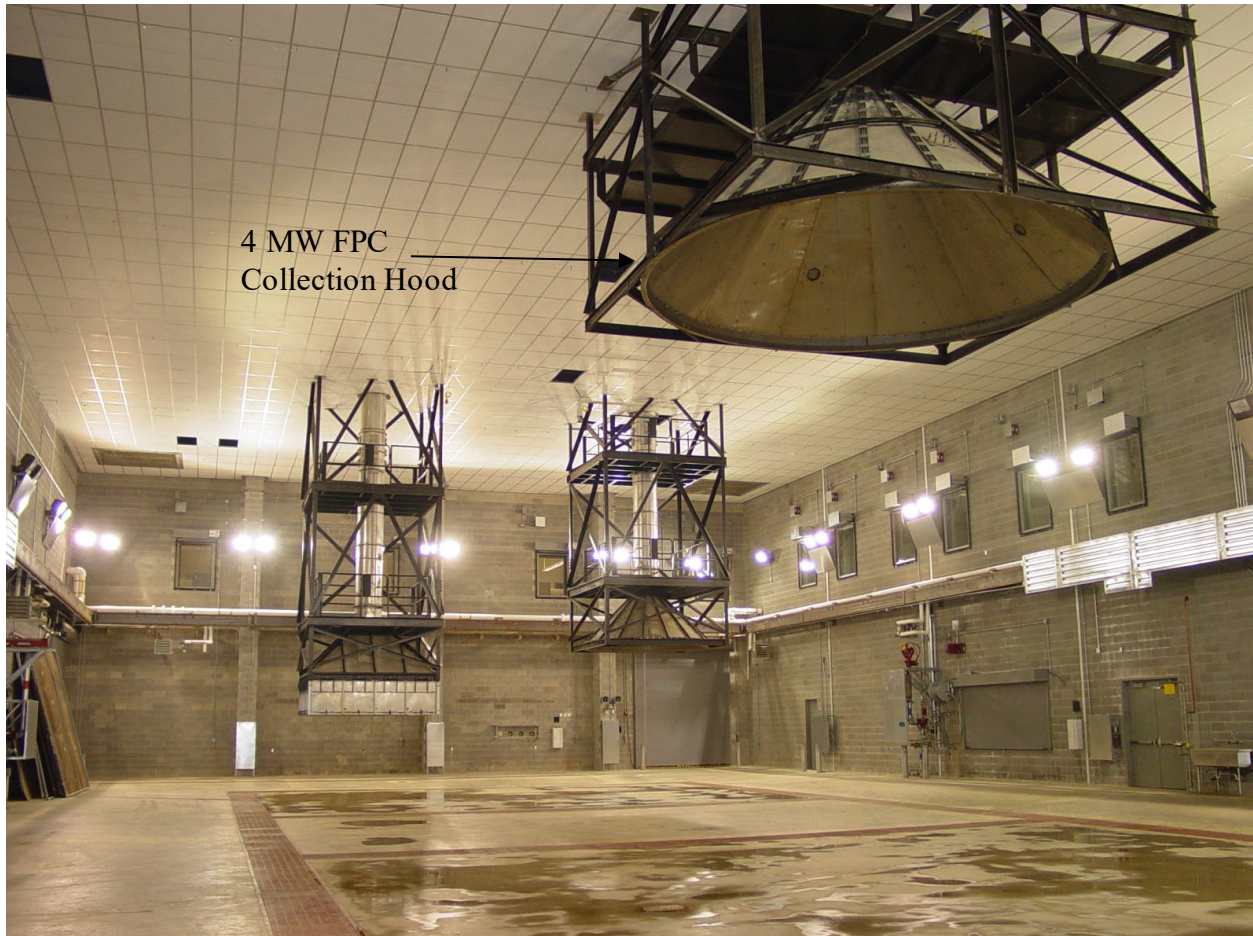

Figure 1: 4 MW FPC

## ***Hood and Collection System***

### **Physical Dimensions**

Figure 2 shows a plan view schematic of the 4 MW FPC collection hood in the MBR. The 5.8 m diameter collection hood transitions to a circular exhaust duct with an internal diameter of 1.35 m. A 0.82 m diameter orifice plate is located in the horizontal section of the duct, downstream of the 90° bend approximately 3.2 m from the centerline of the vertical section. The orifice enhances mixing of the fire products prior to reaching the instrumentation locations. The exhaust duct has a vertical run of approximately 7.3 m before transitioning to a horizontal run above the MBR ceiling. The base of the collection hood is 7.1 m above the MBR floor; however skirts can be added to reduce the height to 4.2 m.

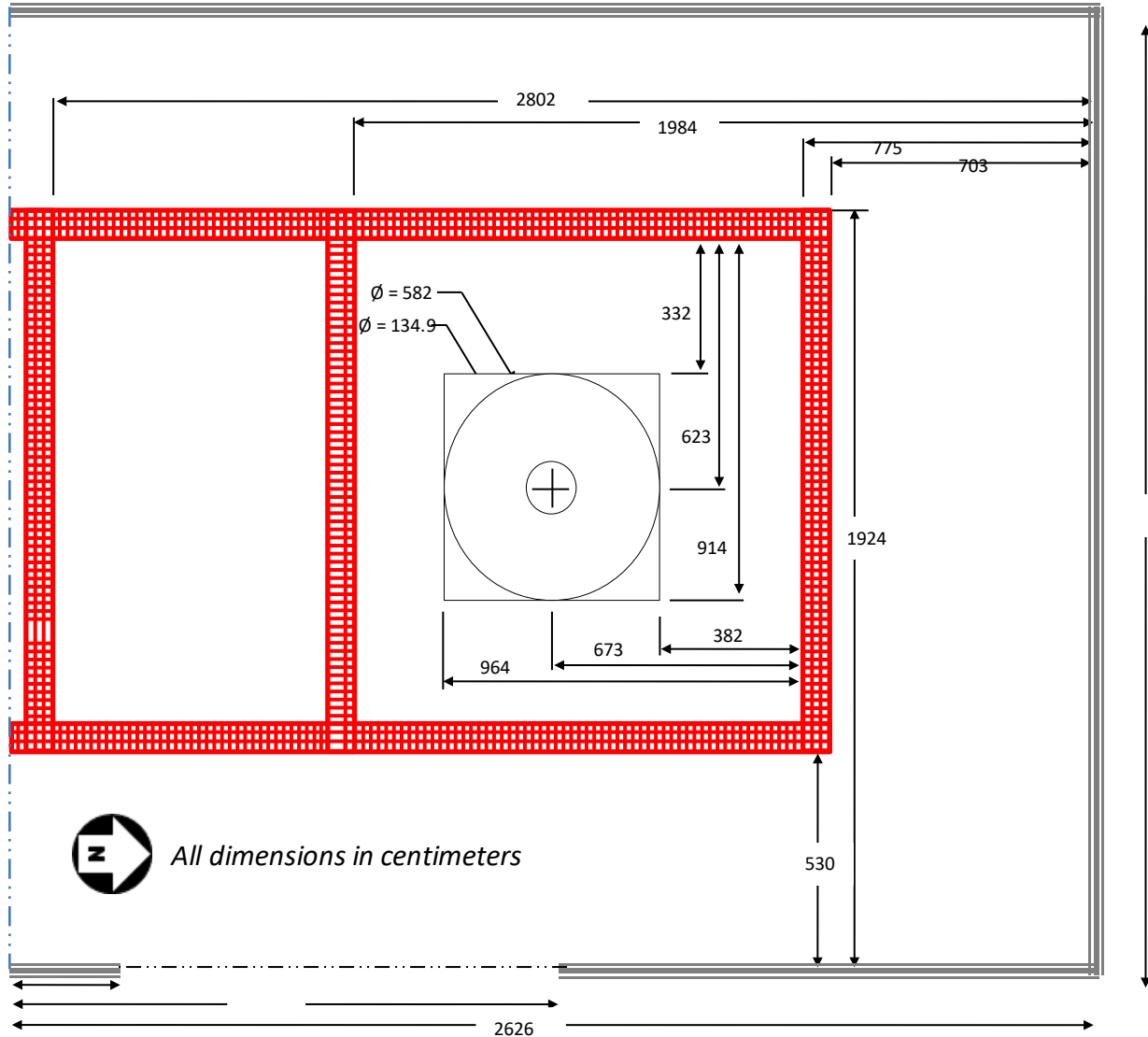

Figure 2: Plan view of 4 MW FPC in the MBR.

### Instrument Locations

Instruments are located in the horizontal run of the FPC exhaust duct as shown in Figure 3. The first two instrument stations are located approximately 7.3 m and 7.7 m downstream of the inlet orifice, and are used for flow measurement. The first flow measurement station is the averaging velocity probes and the second includes the bidirectional probes. The gas sampling probe is



ATF-LS-FRL-TR011c - Fire Products Collectors - 4 MW	ID: 5685 Revision: 2
Authority: Technical Leader	Page: 4 of 30
Original maintained by Quality Programs; copies are uncontrolled.	

located approximately 0.3 m downstream of the bi-directional probe station. The laser smoke measurement station is located approximately 0.3 m downstream of the sampling probe.

### **Flow Control**

Flow in the FPC is controlled by a system of variable speed fans and actuated dampers that are programmed to maintain a fixed mass flow rate. The system is operated by a PC in the FRL Control Room. The FRL FPC's were designed to flow 6.8 kg/s (12,000 SCFM) per 1 MW heat release rate; the design flow rate of the 4 MW FPC is 27.2 kg/s.

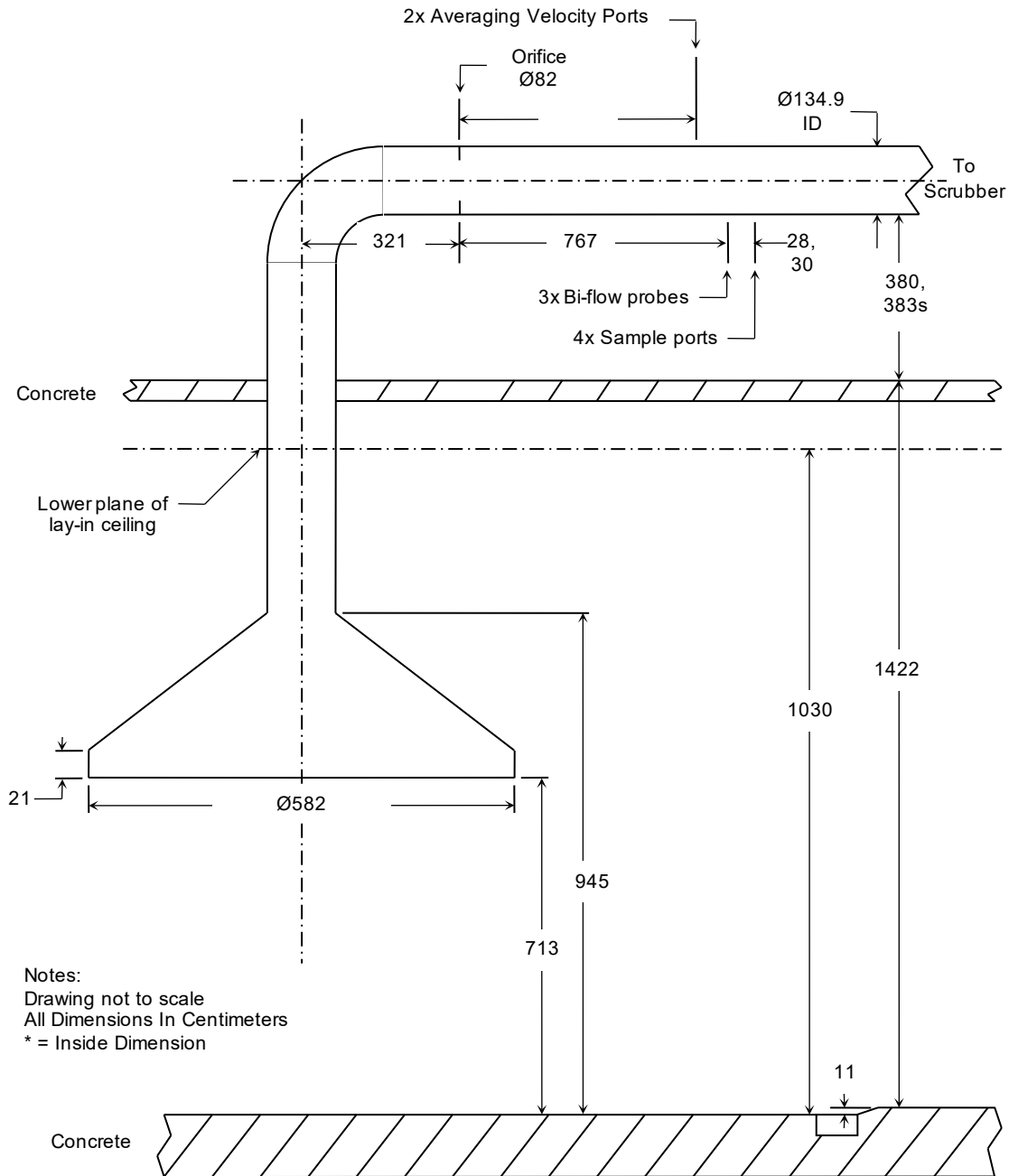

Figure 3: Elevation view of 4 MW FPC in the MBR



ATF-LS-FRL-TR011c - Fire Products Collectors - 4 MW	ID: 5685 Revision: 2
Authority: Technical Leader	Page: 6 of 30
Original maintained by Quality Programs; copies are uncontrolled.	

## ***Instrumentation***

The 4 MW FPC is equipped with instrumentation to measure gas species concentrations, temperature, velocity, and smoke concentration.

### **Gas Species Measurement**

The system of instrumentation used to measure gas species concentrations consists of a gas sampling probe located in the duct, tubing to transport the sample, a pump, sample conditioning equipment, and a gas analyzer.

Figure 4 shows a schematic of the gas sampling probe layout used in the 4 MW FPC. The gas sampling probe consists of two stainless steel tubes with a radial offset of 90° and an axial offset of approximately 5.1 cm (2 inch) between centerlines. Each tube has an outside diameter of 19.1 mm (0.75 inch) and contains 26 sampling holes positioned at 50 mm (2 inch) intervals. The sampling holes have diameters of either 3 mm or 4 mm. Figure 5 shows a detailed schematic of the gas sampling probe.

The gas sampling probe is installed with one tube oriented vertically and the other oriented horizontally with the sampling holes facing downstream; the tubes overlap at the center of the exhaust duct. The probe is located in 8 m downstream of the inlet orifice. Sample is drawn from both ends of each tube and transported to the gas analysis rack through a single 9.5 mm (3/8 inch) diameter Teflon gas sampling line.

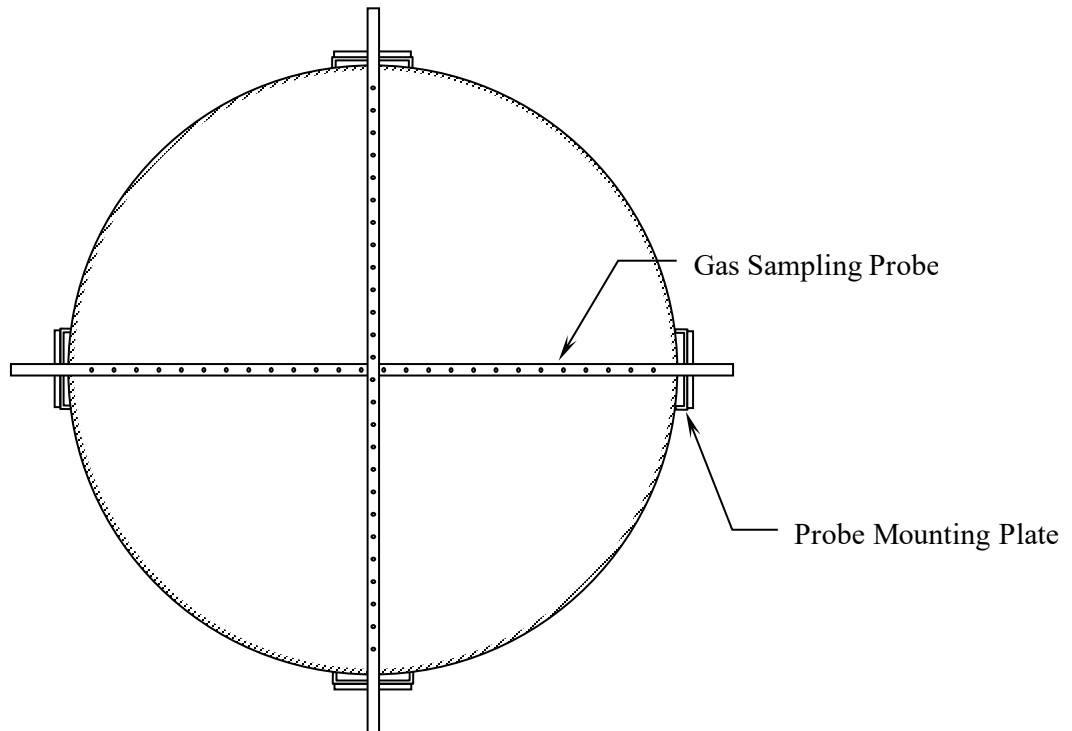

Figure 4. Schematic of the gas sampling probe mounted in the duct

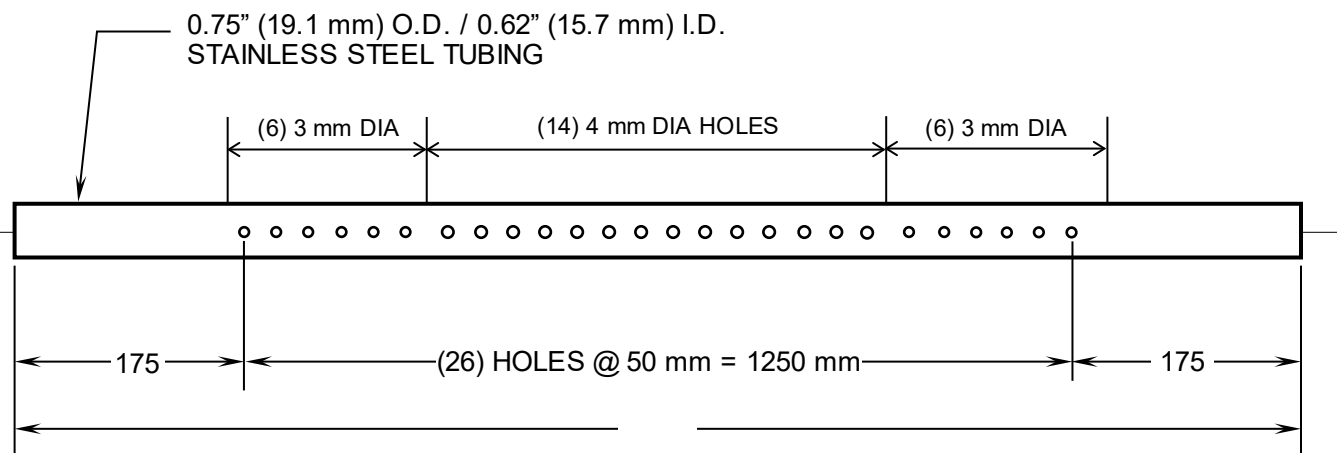

Figure 5. Detailed schematic of the gas sampling probe showing hole locations



Tubing from the gas sampling probe is connected to a gas analysis rack constructed by Fire Testing Technology Limited (FTT), shown in Figure 6. This rack, located in a conditioned space on the mezzanine level above the MBR, includes a Servomex 4100C Xentra gas analyzer, gas train, pressure and flow control, filtering, and moisture removal.



**Figure 6: Photo of the 4 MW FPC gas analysis rack**

The gas analyzer is configured to measure oxygen, carbon monoxide and carbon dioxide. Table 1 lists the output range for these three gas species measured for the 4 MW FPC. Additional details on the gas analyzer rack are provided elsewhere [2 - 4].

A delay exists between the time that the gas sample is extracted from the duct and the time it reaches the analyzer. This delay time is determined by introducing a step-change in gas composition flowing past the gas sampling probe and monitoring the output of the analyzer for change in measured gas concentration. The delay time used in each experiment is documented in the FireTOSS datasheet. The gas analyzer was modified by Servomex to permit higher sample flow rates in order to reduce the sample delay times [4, 5].



ATF-LS-FRL-TR011c - Fire Products Collectors - 4 MW	ID: 5685 Revision: 2
Authority: Technical Leader	Page: 9 of 30
Original maintained by Quality Programs; copies are uncontrolled.	

**Table 1. Servomex 4100C gas species measurement ranges.**

<b>Gas Species</b>	<b>Range</b>
Oxygen (O <sub>2</sub> )	0 – 25 %
Carbon Dioxide (CO <sub>2</sub> )	0 – 10 %
Carbon Monoxide (CO)	0 – 1 %

## **Flow Measurement**

The flow of gases in the duct is measured using a pressure transducer, velocity probe, and thermocouple. Details on the use of differential pressure probes for velocity measurements are contained in the Laboratory Instruction [6].

### Pressure Transducer

A Setra model 267 pressure transducer with a range of 0 – 620 Pa (0 – 2.5 inches of water) and an output of 4 – 20 mA is used for differential pressure measurement in the 4 MW FPC [7]. The transducer is connected to the differential pressure probes through a set of valves that can be closed to facilitate baseline readings and probe purging.

### Velocity Probe

Velocity measurements in the 4 MW FPC are performed using a pair of bi-directional probes [8]. Figure 7 shows a schematic of the probe. The probe consists of two ports; one facing upstream and the other downstream. The differential pressure measured between the two ports is used to calculate the velocity at the probe location. A flow shape factor is applied to calculate the average duct velocity. The probes are mounted to the exterior of the duct via a 19 cm diameter mounting plate. All components are constructed of stainless steel. Additional details on the use of differential pressure probes for velocity measurements are contained in the Laboratory Instruction [6] and Technical Reference [9].

The 4 MW FPC duct is equipped with additional velocity probes. A pair of VOLU-probe/1SS Stainless Steel Pitot Airflow Traverse Probes [10] is mounted approximately 39 cm upstream of the bi-directional probes, as shown in Figure 3. Figure 8 shows a schematic of the probe. The probe consists of two manifolds; one each for static and total pressure measurement. Each manifold has pressure ports spaced at equal area intervals, producing a pressure representing the instantaneous average across the duct. The probes are mounted to the exterior of the duct via a 15 cm x 15 cm mounting plate on one end, with the opposite end secured by a pin support. Two probes are mounted at a 90° angle, per manufacturer specifications [11]. All components are constructed of stainless steel. Additional details on the use of differential pressure probes for velocity measurements are contained in the Laboratory Instruction [6] and Technical Reference [12].

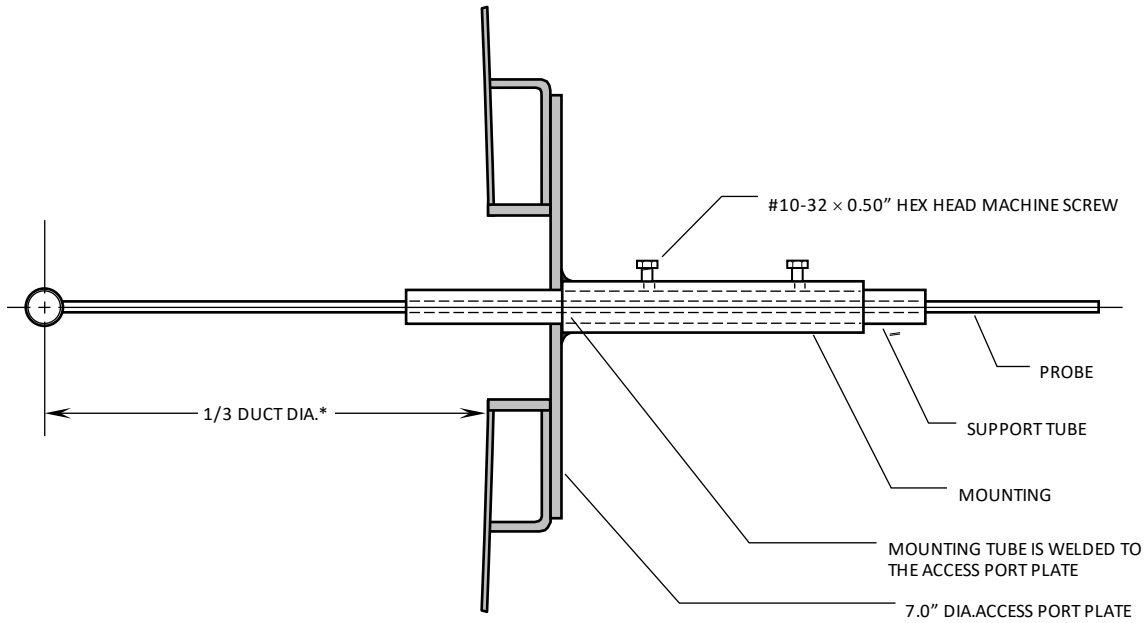

Figure 7: Schematic of the bi-directional probes.

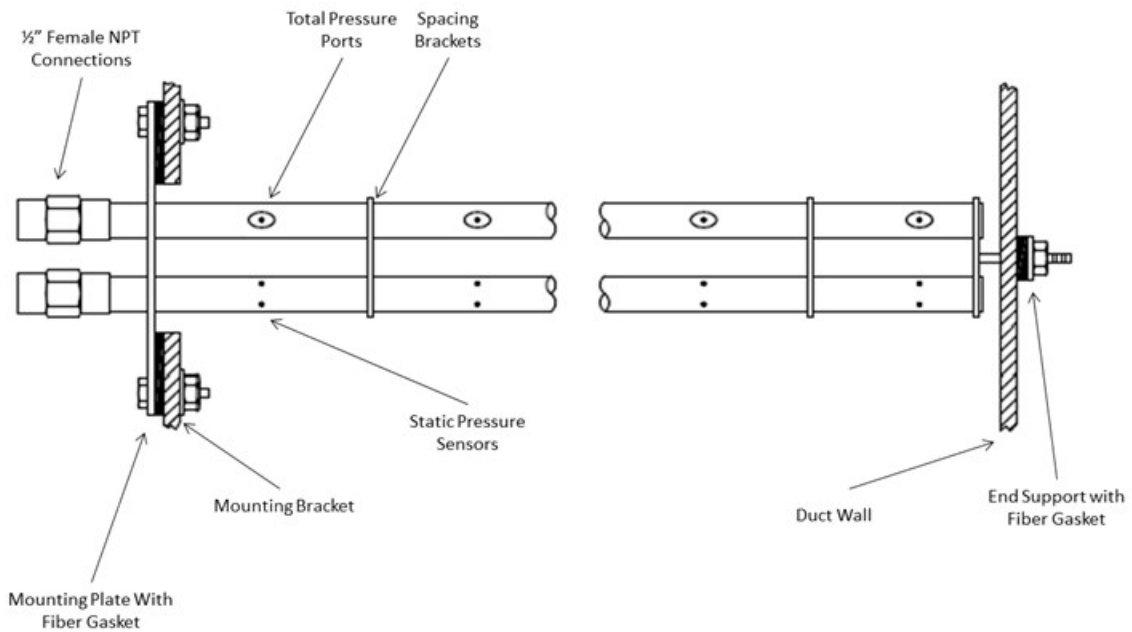

Figure 8: Schematic of the Voluprobe/1SS [10]



ATF-LS-FRL-TR011c - Fire Products Collectors - 4 MW	ID: 5685 Revision: 2
Authority: Technical Leader	Page: 11 of 30
Original maintained by Quality Programs; copies are uncontrolled.	

### Thermocouple

Two 1.5 mm (0.062 inch) Inconel-sheathed Type K special limits of error (SLE) thermocouples are used to monitor the gas temperature at each bi-directional probe location in the 4 MW FPC duct. Type K thermocouples have a peak temperature range of approximately 1250°C (2282 °F). Type-K SLE thermocouple wire has a minimum accuracy of the greater of 1.1°C or 0.4% of the temperature reading over 0°C. Additional information on thermocouples can be found in the Laboratory Instruction [13].

### **Smoke Measurement**

Smoke is measured in the 4 MW FPC using laser optical density meters (ODMs) [14, 15]. The ODM access ports are located approximately 0.3 m downstream of the gas sampling probes.

The laser ODM uses a low-power (0.5 mW) Helium-Neon (HeNe) laser that emits continuous light at 632 nm. The laser ODM uses two photodiode detectors; the main detector is used to measure the beam intensity as it is attenuated by the smoke and fire gases in the FPC. A compensating detector located near the laser head is used to account for changes in the laser output during a test so that these are not erroneously attributed to smoke attenuation by the main detector.

### **Data Acquisition**

Data acquisition for the 4 MW FPC is achieved using an Allen Bradley (AB) SLC 500 series Programmable Logic Controller (PLC). Instruments are connected to the FireTOSS network through a SLC 5/05 processor, with an IP address of 10.243.235.183. The FPC instrumentation and the corresponding FireTOSS tag are listed in Table 2. The SLC 500 is located on the east wall of a compartment located on the mezzanine level, above the MBR. This compartment houses the data acquisition and gas analysis instrumentation for all of the MBR FPCs.

**Table 2. Data Acquisition Setup**

<b>Devices Attached</b>	<b>Quantity Measured</b>	<b>FireTOSS Tag</b>
Laser ODM – Main	Light transmission	AB183_AI01_00
Laser ODM – Compensating	Light transmission	AB183_AI01_01
White Light ODM	Light transmission	AB183_AI01_02
Gas Analyzer – O <sub>2</sub>	Gas Concentration	AB183_AI03_04
Gas Analyzer – CO <sub>2</sub>	Gas Concentration	AB183_AI03_03_F
Gas Analyzer – CO	Gas Concentration	AB183_AI03_05
Bi-directional probe Pressure Transducer	Pressure	AB183_AI03_00_F



ATF-LS-FRL-TR011c - Fire Products Collectors - 4 MW	ID: 5685 Revision: 2
Authority: Technical Leader	Page: 12 of 30
Original maintained by Quality Programs; copies are uncontrolled.	

Devices Attached	Quantity Measured	FireTOSS Tag
Bi-directional probe Pressure Transducer	Pressure	AB183_AI03_01_F
Thermocouple 1	Temperature	AB183 TC09 01
Thermocouple 2	Temperature	AB183 TC09 02
Thermocouple 3	Temperature	AB183 TC09 03
Thermocouple 4	Temperature	AB183 TC09 04

### **Measurement Range**

The practical HRR measurement range for the 4 MW FPC is from approximately 50 kW to 5600 kW. This range represents a range of HRR values over which the 4 MW FPC has a linear response. The minimum change in HRR that can be resolved with the 4 MW FPC is approximately 25 kW. Data from calibration experiments performed over the full measurement range of the FPC are shown in Appendix A.

### **Calibration**

A calibration burner [16] is used to determine the calibration factor, or C Factor, for a FPC. The type of calibration burner is selected based on the desired maximum HRR needed for the calibration. For the 4 MW FPC, a natural gas tube burner [17] is used to determine the C Factor.

### **Calculations**

The calculations used to determine the HRR, and other output quantities, from the FPC are defined in the FPC Laboratory Instruction [1].

### **Uncertainty and Accuracy**

Fire Products Collectors are designed to provide four primary quantities: heat release rate (HRR), convective heat release rate (CHRR), gas species production and smoke production. The uncertainty associated with each of these quantities, calculated from measurements in the 4 MW FPC, was estimated using the guidelines of the National Institute of Standards and Technology (NIST) Special Publication 1007 [18], Technical Note 1297 [19], and the NIST Uncertainty Workshop [20]. The analysis outlined below is based primarily on data collected from natural gas fires generated using the FRL tube burner; the burner output was fixed for a period of five minutes at progressively increasing HRR levels [1, 17]. Uncertainty was calculated for nominal fire sizes of 400 kW, 2600 kW and 5400 kW, representing low, middle and high ends of the operating range.



ATF-LS-FRL-TR011c - Fire Products Collectors - 4 MW	ID: 5685 Revision: 2
Authority: Technical Leader	Page: 13 of 30
Original maintained by Quality Programs; copies are uncontrolled.	

The combined standard uncertainty for a calculated output  $y$ , based on a number ( $i$ ) of uncorrelated input quantities  $x_i$ , is a combination of the uncertainty of each component. It is expressed mathematically by the following equation:

$$u_c(y) = k \sqrt{\sum s_i^2 u(x_i)^2} \quad (1)$$

where:

- $u_c(y)$  = Combined standard uncertainty in the output  $y$
- $u(x_i)$  = Standard uncertainty of each component  $x_i$
- $s_i$  = Sensitivity coefficient associated with each component ( $\partial/\partial x_i$ )
- $k$  = Coverage factor

The expression used to calculate the oxygen consumption HRR is a complex function of multiple variables and physical constants [1, 21]. The formulations used to calculate CHRR, gas species production and smoke production are considerably simpler and use many of the same measured input variables [1]. The approach taken in this analysis was to calculate the uncertainty in the HRR first. This necessitates calculating the standard uncertainty for most of the variables and parameters used in the other output quantities. A spreadsheet formulation was used to apply Equation (1) to perform the uncertainty calculations [22].

Table 3 summarizes the combined standard uncertainty for each output quantity of the 4 MW FPC. The HRR, CHRR, CO<sub>2</sub> and CO production rate values are based on data collected from the natural gas calibration burner experiments. Because the natural gas fires produce relatively little smoke, data for the rate of smoke release (RSR) are from a separate experiment. The RSR data is from an upholstered furniture fire with a peak HRR of approximately 5500 kW. Details on how these uncertainty values were determined are provided in the sections that follow.

**Table 3. Uncertainty Summary**

Quantity	Calculated Value	Combined Standard Uncertainty	Relative Uncertainty
Heat Release Rate (HRR)	2565 kW	149	5.8 %
Convective Heat Release Rate	2077 kW	110	5.3 %
Mass Production Rate – CO <sub>2</sub>	108 g/s	5.7	5.3 %
Mass Production Rate – CO	0.72 g/s	0.11	14.9 %
Rate of Smoke Release – Laser	122 m <sup>2</sup> /s	7.2	5.9 %



## Heat Release Rate

The oxygen consumption heat release rate is calculated according to [1]:

$$HRR = C \left[ E\phi - (E_{CO} - E) \frac{1 - \phi}{2} \frac{X_{CO}}{X_{O_2}} \right] \left( \frac{\dot{m}}{1 + \phi(\alpha - 1)} \right) \left( \frac{MW_{O_2}}{MW_{air}} \right) (1 - X_{H_2O}^0) X_{O_2}^0 \quad (2)$$

The oxygen depletion factor,  $\phi$ , in Equation 2 is a function of two co-dependent pairs: the concentrations of oxygen and carbon dioxide in the incoming air and in the product stream ( $X_{O_2}, X_{O_2}^0$ ) ( $X_{CO_2}, X_{CO_2}^0$ ). It has been shown that, under these circumstances, the approach to properly account for the uncertainty is to re-write Equation 2 in terms of the raw inputs [18]. Based on this, Equation (2) was broken down into thirty four components and a standard uncertainty was determined for each. Table 4 shows a list of the components along with a brief description.

**Table 4: Components used in the oxygen consumption HRR calculation**

Component	Description (Units in parentheses)
$A_{O_2}$	Current output from oxygen analyzer (A)
$A_{O_2,zero}$	Current output from oxygen analyzer flowing zero gas (A)
$A_{O_2,span}$	Current output from oxygen analyzer flowing span gas (A)
$A_{O_2,base}$	Current output from oxygen analyzer during pre-test baseline (A)
$X_{O_2,zero}$	Mole fraction of oxygen in zero gas (A)
$X_{O_2,span}$	Mole fraction of oxygen in span gas (A)
$A_{CO_2}$	Current output from carbon dioxide analyzer (A)
$A_{CO_2,zero}$	Current output from carbon dioxide analyzer flowing zero gas (A)
$A_{CO_2,span}$	Current output from carbon dioxide analyzer flowing span gas (A)
$A_{CO_2,base}$	Current output from carbon dioxide analyzer during pre-test baseline (A)
$X_{CO_2,zero}$	Mole fraction of carbon dioxide in zero gas (A)
$X_{CO_2,span}$	Mole fraction of carbon dioxide in span gas (A)
$A_{CO}$	Current output from carbon monoxide analyzer (A)
$A_{CO,zero}$	Current output from carbon monoxide analyzer flowing zero gas (A)
$A_{CO,span}$	Current output from carbon monoxide analyzer flowing span gas (A)
$X_{CO,zero}$	Mole fraction of carbon monoxide in zero gas (A)
$X_{CO,span}$	Mole fraction of carbon monoxide in span gas (A)
$M_{air,dry}$	Molecular weight of dry air (g/mol)
$M_{H_2O}$	Molecular weight of water (g/mol)



ATF-LS-FRL-TR011c - Fire Products Collectors - 4 MW	ID: 5685 Revision: 2
Authority: Technical Leader	Page: 15 of 30
Original maintained by Quality Programs; copies are uncontrolled.	

Component	Description (Units in parentheses)
$M_{O_2}$	Molecular weight of oxygen (g/mol)
$E$	Net heat release of natural gas per kg of oxygen consumed (kJ/kg)
$E_{CO}$	Net heat release of carbon monoxide per kg of oxygen consumed (kJ/kg)
$\alpha$	Volumetric expansion factor (--)
RH	Relative humidity of incoming air (%)
$P_{amb}$	Ambient pressure (Pa)
$T_{amb}$	Ambient temperature (K)
$C_{bdp}$	Bi-directional probe constant (--)
$f$	Velocity flow shape factor (--)
D	Duct diameter (m)
$T_1$	Duct temperature at sampling location 1 (K)
$T_2$	Duct temperature at sampling location 2 (K)
$A_{dp,meas1}$	Current output from pressure transducer at sampling location 1(A)
$A_{dp,meas2}$	Current output from pressure transducer at sampling location 2(A)
$A_{dp,zero}$	Current output from the pressure transducer during pre-test baseline (A)

Variables and constants are grouped in Table 4 according to four primary categories: gas species concentrations, physical constants, ambient conditions and mass flow rate. A discussion of the uncertainty analysis for each category is given below.

#### Gas Species Concentration

ASTM E 2536 identifies three sources of error that should be considered in the estimation of uncertainty for oxygen measurements in a cone calorimeter: the data acquisition system, random (Type A) scatter in the data signal, and calibration [23]. Instrumentation used in the cone calorimeter is similar to what is used in large scale calorimeter hoods such as the 4 MW FPC. Based on this, these three sources of error were considered for the gas species uncertainty evaluation ( $O_2$ ,  $CO_2$  and  $CO$ ) performed here. A fourth source, calibration gas error, was added based on discussions with the instrument retailer [24].

Table 4 lists two components that contribute to gas species measurements: the unscaled analyzer signal ( $A_i$ ) and the mole fractions in the calibration gases ( $X_i$ ). The following sections provide details related to the uncertainty estimate for each component.

#### Analyzer Signal Uncertainty

The uncertainty estimate in the recorded analyzer signal included contributions from the data acquisition hardware and fluctuations in the data. The contribution from data acquisition hardware came from manufacturer's specifications. The uncertainty contribution associated with data fluctuations came from a statistical analysis of the raw signal collected in a calibration burner experiment.



ATF-LS-FRL-TR011c - Fire Products Collectors - 4 MW	ID: 5685 Revision: 2
Authority: Technical Leader	Page: 16 of 30
Original maintained by Quality Programs; copies are uncontrolled.	

The Servomex gas analyzer used in the 4 MW FPC sends an analog 4 – 20 mA signal to an Allen Bradley (AB) SLC 500 series programmable logic controller (PLC) through a 1746 NI16I 16 bit I/O module. Specifications for the AB hardware include a digital resolution of 640 nA and a calibrated accuracy of better than 0.15 % of range [25].

The standard uncertainty associated with fluctuations in the analyzer signal was estimated using the sample standard deviation. Calculations were performed using data recorded when the analyzer output was steady. Analyzer signals listed in Table 4 are divided into two categories: calibration ( $A_{i,zero}$ ,  $A_{i,span}$ ) and experiment ( $A_i$ ,  $A_{i,base}$ ). For the calibration signal uncertainty, the sample standard deviation was calculated over one minute periods during an ‘AUTOCAL’ cycle. For the experiment signal uncertainty the sample standard deviation was calculated during a calibration burner experiment. Statistics were performed for data spanning several minutes.

The combined uncertainty was calculated by combining the data acquisition and statistical components.

#### *Calibration Gas Uncertainty*

The 4 MW FPC is equipped with a modified Servomex Xentra 4100 gas analyzer that contains individual cells to measure each of the three species concentrations. Oxygen concentration is measured in a paramagnetic cell with 0 – 25 % range; CO<sub>2</sub> and CO are measured in non-dispersive infrared (NDIR) cells with peak concentration ranges of 10 % and 1 %, respectively. Each cell is calibrated using zero and span gases. The zero gas and CO / CO<sub>2</sub> span gas come with certifications from the supplier. The oxygen analyzer is spanned with ambient air; the uncertainty estimate for ambient O<sub>2</sub> concentration was taken from the literature [18].

The zero gas is “Zero” grade (99.99 %) nitrogen. Assuming a rectangular distribution, the standard uncertainty is +/-  $5.8 \times 10^{-5}$ . The CO/CO<sub>2</sub> span gas is a Primary Standard grade mixture with certified accuracy of 1% for CO and 0.02 % for CO<sub>2</sub>. The concentrations of CO and CO<sub>2</sub> in the span gas are nominally 0.8 % and 8 %, respectively, with the balance comprised of N<sub>2</sub>. Assuming a rectangular distribution, the standard uncertainties of CO<sub>2</sub> and CO in the span gas are estimated to be  $1.2 \times 10^{-4}$  and  $4.6 \times 10^{-5}$ , respectively. Laboratory air is used to span the oxygen analyzer; the concentration is taken as 20.95 %. The estimated uncertainty associated with the oxygen span concentration is estimated to be 0.05 % [18]. This estimate was verified through a comparison with a high purity certified O<sub>2</sub>/N<sub>2</sub> mixture.

#### *Physical Constants*

Physical constants include the molecular weights of oxygen ( $M_{O_2}$ ), dry air ( $M_{air,dry}$ ) and water ( $M_{H_2O}$ ), in addition to the volumetric expansion factor ( $\alpha$ ) and the net heat release per unit mass of oxygen consumed for natural gas ( $E$ ) and carbon monoxide ( $E_{CO}$ ). The standard uncertainty



ATF-LS-FRL-TR011c - Fire Products Collectors - 4 MW	ID: 5685 Revision: 2
Authority: Technical Leader	Page: 17 of 30
Original maintained by Quality Programs; copies are uncontrolled.	

of the molecular weights was taken as zero. The standard uncertainties of the remaining constants were based on previous work and summarized in Table 5 [18].

**Table 5: Summary of uncertainty in physical constants**

Parameter	Value	Standard Uncertainty
$\alpha$ (--)	1.104	0.048
$E$ (kJ/kg O <sub>2</sub> )	12550	19.95
$E_{CO}$ (kJ/kg O <sub>2</sub> )	17690	10

#### Ambient Conditions

Ambient conditions are measured using a wall mounted weather station that is permanently housed in the MBR. The weather station measures relative humidity, temperature and absolute pressure. Additional information, including the uncertainty analysis for each of the measured quantities, can be found in the laboratory instruction [28]. Table 6 shows a summary of the standard uncertainty for the ambient temperature, pressure and relative humidity.

**Table 6: Ambient conditions uncertainty summary**

Quantity	Standard Uncertainty
T <sub>a</sub> (°C)	0.6
P <sub>a</sub> (Pa)	115.5
RH (%)	2.2

#### Mass Flow Rate

The mass flow rate is expressed as:

$$\dot{m} = \rho \dot{V} \quad (3)$$

where  $\rho$  is the gas density (kg/m<sup>3</sup>) and  $\dot{V}$  is the volumetric flow rate (m<sup>3</sup>/s). The density was expressed in terms of temperature using the ideal gas law:

$$\rho = \rho_{std} \frac{T_{std}}{T} \quad (4)$$

where the standard condition is taken as 300 K and 1 atm. The volumetric flow rate was calculated using:



ATF-LS-FRL-TR011c - Fire Products Collectors - 4 MW	ID: 5685 Revision: 2
Authority: Technical Leader	Page: 18 of 30
Original maintained by Quality Programs; copies are uncontrolled.	

$$\dot{V} = f A V \quad (5)$$

where  $f$  is the flow shape factor,  $A$  is the duct area ( $\text{m}^2$ ) and  $V$  is the velocity ( $\text{m/s}$ ). The flow shape factor was calculated using data from flow traverse measurements conducted previously [29]. The duct area is a function of the diameter,  $D$  (1.35 m). The velocity was calculated according to [6]:

$$V = \sqrt{\frac{2 \Delta P T}{\rho_{std} T_{std}}} / C_{bdp} \quad (6)$$

where  $\Delta P$  is the differential pressure measured by the velocity probe (Pa) and  $T$  (K) is the temperature inside the duct.  $C_{bdp}$  is the bi-directional probe factor that has been shown to be a constant ( $1.08 \pm 5\%$ ) over the range of Reynolds numbers encountered in the duct flow [8]. Combining the above equations and substituting ( $T_{std} = 300 \text{ K}$ ,  $\rho_{std} = 1.18 \text{ kg/m}^3$ ) yields:

$$\dot{m} = \frac{20.875 D^2 f}{C_{bdp}} \sqrt{\frac{\Delta P}{T}} \quad (7)$$

The temperature was taken as the average of four independent measurements at each time step and the differential pressure was expressed as:

$$\begin{aligned} \Delta P &= \Delta P_{meas} - \Delta P_{baseline} \\ &= (m_{dp} A_{dp} + b_{dp})_{meas} - (m_{dp} A_{dp} + b_{dp})_{baseline} \end{aligned} \quad (8)$$

where  $m_{dp}$  and  $b_{dp}$  are the calibration factors for the differential pressure transducer. The differential pressure is corrected by subtracting a baseline value, which is measured in a separate experiment with the transducer cross-ported. Consolidating terms, the differential pressure can be expressed as:

$$\Delta P = m_{dp} (A_{dp,meas} - A_{dp,baseline}) \quad (9)$$

The calibration constant,  $m_{dp}$ , for the pressure transducer was 38920.1 Pa/A. This yields the expression for mass flow rate:

$$\dot{m} = \frac{4118.26 D^2 f}{C_{bdp}} \sqrt{\frac{A_{dp,meas} - A_{dp,baseline}}{T}} \quad (10)$$



ATF-LS-FRL-TR011c - Fire Products Collectors - 4 MW	ID: 5685 Revision: 2
Authority: Technical Leader	Page: 19 of 30
Original maintained by Quality Programs; copies are uncontrolled.	

The standard uncertainty in the diameter measurement was calculated from the standard deviation of six independent measurements. The result was  $D = 1.349 \pm 0.002$  m. To account for the duct not being perfectly circular this uncertainty was increased to  $\pm 0.005$  m. The standard uncertainty in the flow shape factor ( $f$ ) was estimated based on the standard error in the least squares regression from the traverse data [29]. The standard uncertainty in the each temperature measurement was estimated by combining the fundamental error limit of the probe and the sample standard deviation of data calculated during a calibration burner experiment. The standard uncertainty in the average temperature was calculated by combining uncertainties in the individual measurements using Eqn. (1).

The combined standard uncertainty in the pressure transducer data was calculated based on manufacturer's specifications for the data acquisition hardware and pressure transducer, in addition to a statistical analysis of the signal. The data acquisition hardware is the same as what is used for the gas analyzers; the standard uncertainty is  $7.1 \times 10^{-8}$  A. The standard uncertainty for a Setra model 267 pressure transducer is a function of the input range for the instrument; for a device with input range  $\Delta P = 0 - 0.62$  kPa (0 - 2.5 inch H<sub>2</sub>O) the standard uncertainty is  $5.2 \times 10^{-5}$  A [12]. The uncertainty associated with data fluctuation in the transducer output was calculated from the sample standard deviation collected during a calibration burner experiment. Table 7 shows a summary of the combined standard uncertainty for the pressure measurement for three fire sizes and a baseline.

**Table 7: Combined standard uncertainty in the differential pressure measurement.**

Fire Size	Combined Standard Uncertainty (A)
Baseline	$5.2 \times 10^{-5}$
370 kW	$3.0 \times 10^{-4}$
2565 kW	$2.6 \times 10^{-4}$
5370 kW	$3.0 \times 10^{-4}$

Summary

Table 8 shows a summary of the uncertainty in the oxygen consumption heat release rate performed for three fire sizes. The first column lists the 26 components (with units in parentheses) that comprise the oxygen consumption HRR calculation, as described in Table 4. For each component, the nominal value obtained for a 2565 kW fire is listed in column 2. Column 3 lists the standard uncertainty for each component that was discussed in the preceding sections. Columns 4 – 6 list the sensitivity coefficients calculated for fire sizes of 370 kW, 2565 kW and 5370 kW.



ATF-LS-FRL-TR011c - Fire Products Collectors - 4 MW	ID: 5685 Revision: 2
Authority: Technical Leader	Page: 20 of 30
Original maintained by Quality Programs; copies are uncontrolled.	

**Table 8: Summary of HRR uncertainty calculations**

Variable / Parameter $x_i$	Nominal Value	Standard Uncertainty $u(x_i)$	Sensitivity Coefficient $ s_j $		
			370 kW	2565 kW	5370 kW
$A_{O_2}$	0.01699	$9.9 \times 10^{-6}$	$6.9 \times 10^6$	$6.4 \times 10^6$	$5.8 \times 10^6$
$A_{O_2,zero}$	0.00400	$1.2 \times 10^{-6}$	$3.2 \times 10^4$	$2.1 \times 10^5$	$4.3 \times 10^5$
$A_{O_2,span}$	0.01741	$1.0 \times 10^{-6}$	$3.5 \times 10^4$	$2.4 \times 10^5$	$5.0 \times 10^5$
$A_{O_2,base}$	0.01743	$1.2 \times 10^{-6}$	$6.9 \times 10^6$	$6.4 \times 10^6$	$5.9 \times 10^6$
$X_{O_2,zero}$	0.00000	$5.8 \times 10^{-5}$	$2.1 \times 10^3$	$1.3 \times 10^5$	$2.8 \times 10^4$
$X_{O_2,span}$	0.20950	$5.0 \times 10^{-4}$	$2.2 \times 10^3$	$1.5 \times 10^5$	$3.2 \times 10^4$
$A_{CO_2}$	0.00454	$4.4 \times 10^{-6}$	$5.7 \times 10^5$	$5.2 \times 10^5$	$4.5 \times 10^5$
$A_{CO_2,zero}$	0.00400	$2.2 \times 10^{-7}$	$4.6 \times 10^3$	$2.2 \times 10^4$	$4.6 \times 10^4$
$A_{CO_2,span}$	0.01680	$8.1 \times 10^{-7}$	$4.3 \times 10^3$	$1.9 \times 10^4$	$4.2 \times 10^4$
$A_{CO_2,base}$	0.00406	$1.4 \times 10^{-6}$	$5.7 \times 10^5$	$5.2 \times 10^5$	$4.6 \times 10^5$
$X_{CO_2,zero}$	0.00000	$5.8 \times 10^{-5}$	$7.3 \times 10^2$	$3.5 \times 10^3$	$7.4 \times 10^3$
$X_{CO_2,span}$	0.08000	$1.2 \times 10^{-4}$	$6.9 \times 10^2$	$3.1 \times 10^3$	$6.7 \times 10^3$
$A_{CO}$	0.00402	$3.3 \times 10^{-6}$	$1.0 \times 10^5$	$9.3 \times 10^4$	$8.4 \times 10^4$
$A_{CO,zero}$	0.00400	$6.5 \times 10^{-7}$	$1.0 \times 10^5$	$9.3 \times 10^4$	$8.4 \times 10^4$
$A_{CO,span}$	0.01680	$7.9 \times 10^{-6}$	$2.8 \times 10^2$	$1.1 \times 10^2$	$2.5 \times 10^2$
$X_{CO,zero}$	0.00000	$5.8 \times 10^{-5}$	$1.6 \times 10^5$	$1.5 \times 10^5$	$1.3 \times 10^5$
$X_{CO,span}$	0.00800	$4.6 \times 10^{-5}$	$4.5 \times 10^2$	$1.8 \times 10^2$	$4.0 \times 10^2$
$M_{air,dry}$ (g/mol)	28.97	0	0	0	0
$M_{H_2O}$ (g/mol)	18	0	0	0	0
$M_{O_2}$ (g/mol)	32	0	0	0	0
$E$ (kJ/kg)	12550	19.95	$3.0 \times 10^{-2}$	$2.0 \times 10^{-1}$	$4.3 \times 10^{-1}$
$E_{CO}$ (kJ/kg)	17690	10	$3.1 \times 10^{-4}$	$1.2 \times 10^{-4}$	$2.8 \times 10^{-4}$
$\alpha$ (--)	1.104	0.048	$1.9 \times 10^0$	$9.6 \times 10^1$	$4.5 \times 10^2$
RH (%)	47.01	2.16	$8.5 \times 10^{-2}$	$3.4 \times 10^{-1}$	$7.1 \times 10^{-1}$
$P_{amb}$ (Pa)	100105	115.5	$4.8 \times 10^{-5}$	$1.6 \times 10^{-4}$	$3.3 \times 10^{-4}$
$T_{amb}$ (K)	291.41	0.44	$2.9 \times 10^{-1}$	$1.0 \times 10^0$	$2.1 \times 10^0$
$C_{bdp}$	1.08	0.054	$3.3 \times 10^2$	$2.3 \times 10^3$	$4.7 \times 10^3$
$f$ (--)	1.0825	$8.0 \times 10^{-3}$	$3.4 \times 10^2$	$2.4 \times 10^3$	$4.9 \times 10^3$
D (m)	1.349	0.005	$5.5 \times 10^2$	$3.8 \times 10^3$	$8.0 \times 10^3$
$T_1$ (K)	378.26	1.13	$2.9 \times 10^{-1}$	$1.7 \times 10^0$	$2.8 \times 10^0$
$T_2$ (K)	378.07	1.12	$3.0 \times 10^{-1}$	$1.7 \times 10^0$	$2.8 \times 10^0$
$A_{dp,meas,1}$ (A)	0.00903	$2.5 \times 10^{-4}$	$1.9 \times 10^4$	$1.2 \times 10^5$	$2.3 \times 10^5$



ATF-LS-FRL-TR011c - Fire Products Collectors - 4 MW	ID: 5685 Revision: 2
Authority: Technical Leader	Page: 21 of 30
Original maintained by Quality Programs; copies are uncontrolled.	

Variable / Parameter $x_i$	Nominal Value	Standard Uncertainty $u(x_i)$	Sensitivity Coefficient $ s_i $		
			370 kW	2565 kW	5370 kW
$A_{dp,meas,2}$ (A)	0.00946	$2.8 \times 10^{-4}$	$1.8 \times 10^4$	$1.2 \times 10^5$	$2.3 \times 10^5$
$A_{dp,zero}$ (A)	0.00404	$5.2 \times 10^{-5}$	$3.8 \times 10^4$	$2.5 \times 10^5$	$4.6 \times 10^5$

The combined standard uncertainty for each fire size was calculated by combining terms in Table 8 according to Equation 1. The results are summarized in Table 9; the values represent a coverage factor of  $k = 1$ . In the case of a normal distribution, this translates to a confidence level of approximately 68%. To obtain a higher confidence level a higher coverage factor can be applied. A coverage factor of  $k = 2$  in a normally distributed population provides a confidence level of approximately 95 %.

**Table 9: Combined standard uncertainty in the heat release rate**

Fire Size (kW)	Combined Standard Uncertainty (kW)	Relative Uncertainty (%)
370	29	7.8
2565	149	5.8
5370	301	5.6

Table 10 shows a list of the variables that contribute most significantly to the combined uncertainty. The HRR is highly sensitive to the oxygen concentration measurements ( $A_{O_2}$ ,  $A_{O_2,base}$ ) as demonstrated by the large sensitivity factor shown for these variables in Table 8. As the fire size increases, the terms associated with the mass flow become more significant ( $C_{bdp}$ ,  $D$ ,  $A_{dp,meas}$ ). These terms account for more than 84 % of the combined uncertainty at 5370 kW, with the differential pressure probe factor ( $C_{bdp}$ ) being dominant.

**Table 10: Contribution to the combined uncertainty**

Variable / Parameter $x_i$	Fire Size		
	370 kW	2565 kW	5370 kW
$A_{O_2}$ (A)	35.7 %	17.9 %	12.1 %
$A_{O_2,base}$ (A)	5.7 %	0.3 %	0.1 %
$X_{CO,zero}$ (--)	10.5 %	0.3 %	0.1 %
$C_{bdp}$ (--)	37.3 %	67.6 %	72.2 %
$D$ (m)	0.9 %	1.6 %	1.8 %
$A_{dp,meas}$ (A)	7.7 %	9.2 %	10.4 %



ATF-LS-FRL-TR011c - Fire Products Collectors - 4 MW	ID: 5685 Revision: 2
Authority: Technical Leader	Page: 22 of 30
Original maintained by Quality Programs; copies are uncontrolled.	

## Convective Heat Release Rate

The convective heat release rate (CHRR) is expressed as:

$$\dot{Q}_c = \dot{m} (h_2 - h_1) \quad (11)$$

where  $\dot{Q}_c$  is the convective heat release rate (kW),  $\dot{m}$  is the mass flow rate (kg/s) and  $h_1$  and  $h_2$  are the enthalpies of the incoming air and product stream, respectively (kJ/kg). The mass flow rate is evaluated in the same manner as in the HRR calculation (Equation 11) and is a function of six quantities ( $A_{dp, meas}$ ,  $A_{dp, baseline}$ ,  $D$ ,  $T$ ,  $C_{bdp}$ ,  $f$ ). The standard uncertainty in each of these is the same as in the HRR analysis.

The enthalpy difference is calculated according to a polynomial fit evaluated over the temperature range:

$$h_2 - h_1 = \left( \alpha T + \beta \frac{T^2}{2} + \gamma \frac{T^3}{3} + \delta \frac{T^4}{4} + \varepsilon \frac{T^5}{5} \right) \Bigg|_{T_1}^{T_2} \quad (12)$$

where  $\alpha$ ,  $\beta$ ,  $\gamma$ ,  $\delta$ ,  $\varepsilon$  are fit parameters. Data used to fit the coefficients was taken from two sources [30,31]. The error associated with the fit parameters is negligible; the uncertainty in enthalpy was assumed to be solely due to error in the temperature measurement<sup>1</sup>. The standard uncertainty in temperature is the same as in the HRR analysis. Table 11 shows a summary of the CHRR and the combined standard uncertainty in the CHRR for each corresponding HRR step; the values represent a coverage factor of  $k = 1$ .

**Table 11: Convective heat release rate uncertainty summary**

HRR (kW)	CHRR (kW)	Combined Uncertainty (kW)	Relative Uncertainty (%)
370	322	24	7.4
2565	2077	110	5.3
5370	4343	227	5.2

## Gas Species Production

The gas species mass production rate is expressed as:

<sup>1</sup> The polynomial fit parameters used for the enthalpy calculation were those for air.



ATF-LS-FRL-TR011c - Fire Products Collectors - 4 MW	ID: 5685 Revision: 2
Authority: Technical Leader	Page: 23 of 30
Original maintained by Quality Programs; copies are uncontrolled.	

$$\dot{m}_x = \dot{m} (X_x - X_{x,base}) \frac{M_x}{M_a} \quad (13)$$

Where  $\dot{m}_x$  is the production rate of species x (kg/s),  $\dot{m}$  is the mass flow rate in the exhaust duct (kg/s),  $X_x$  and  $X_{x,base}$  are the mole fractions of species x in the product stream and the incoming air, respectively (mol/mol),  $M_x$  is the molecular weight of species x (g/mol) and  $M_a$  is the molecular weight of air (g/mol).

All variables in Equation (13) are evaluated in the same manner as in the HRR calculation (Equation 1). The mass flow rate is a function of six quantities ( $A_{dp,meas}$ ,  $A_{dp,baseline}$ ,  $D$ ,  $T$ ,  $C_{bdp}$ ,  $f$ ). The mole fractions are calculated from the analyzer current and calibration concentrations. The standard uncertainty in each of these is the same as in the HRR analysis.

Table 12 and Table 13 show summaries of the combined uncertainty in the CO<sub>2</sub> and CO production rates, respectively, for three fire sizes. The values represent a coverage factor of  $k = 1$ . Relative uncertainty levels in the CO production rate are high mainly because of the low CO levels generated by natural gas fires.

**Table 12: Combined uncertainty in the CO<sub>2</sub> production rate**

HRR (kW)	$\dot{m}_{CO_2}$ (g/s)	Combined Uncertainty (g/s)	Relative Uncertainty (%)
370	23	1.5	6.6
2565	108	5.7	5.3
5370	249	13.2	5.3

**Table 13: Combined uncertainty in the CO production rate**

HRR (kW)	$\dot{m}_{CO}$ (g/s)	Combined Uncertainty (g/s)	Relative Uncertainty (%)
370	0.06	0.24	369
2565	0.72	0.11	14.9
5370	1.2	0.11	9.8

## Smoke Production

The rate of smoke release (RSR) is expressed as:

$$RSR = k\dot{V} \quad (14)$$



ATF-LS-FRL-TR011c - Fire Products Collectors - 4 MW	ID: 5685 Revision: 2
Authority: Technical Leader	Page: 24 of 30
Original maintained by Quality Programs; copies are uncontrolled.	

where  $k$  ( $\text{m}^{-1}$ ) is the optical extinction coefficient measured by the ODM and  $\dot{V}$  ( $\text{m}^3/\text{s}$ ) is the volumetric flow rate in the exhaust duct.

The standard uncertainty for the extinction coefficient is described in the ODM Technical Reference [15]. For the laser system the relative standard uncertainty is less than 1 % for  $k > 0.1 \text{ m}^{-1}$ ; for  $k > 0.2 \text{ m}^{-1}$  the relative uncertainty is less than 0.5 %.

Uncertainty in the volumetric flow rate was calculated in a manner similar to the procedure used for the mass flow rate in the HRR analysis. The volumetric flow rate is a function of the same six quantities as the mass flow rate ( $A_{dp,meas}$ ,  $A_{dp,baseline}$ ,  $D$ ,  $T$ ,  $C_{bap}$ ,  $f$ ).

Smoke data was collected from an experiment in which upholstered furniture was the primary fuel. The peak HRR in this experiment was approximately 5500 kW; at this fire size the extinction coefficient measured by the laser ODM was  $5.0 \text{ m}^{-1}$ , yielding a smoke release rate of  $122 \text{ m}^2/\text{s}$ . The combined standard uncertainty in the RSR under these conditions was 7.2  $\text{m}^2/\text{s}$  or 5.9 %.



ATF-LS-FRL-TR011c - Fire Products Collectors - 4 MW	ID: 5685 Revision: 2
Authority: Technical Leader	Page: 25 of 30
Original maintained by Quality Programs; copies are uncontrolled.	

## References

1. ATF FRL Laboratory Instruction, Fire Products Collectors, ATF-LS-FRL-LI011.
2. ATF FRL Technical Reference, Servomex 4100 Gas Purity Analyzers, ATF-LS-FRL-TR016a.
3. “Automatic Gas Analysis Console & Ducting Users Manual,” Fire Testing Technology Limited, Issue 4.1, January 2003.
4. “Xentra Analyser Installation Manual,” Servomex, Ref 0400/005C/2.
5. “SERVPRO 4100 Series Analyser Supplementary Manual,” Servomex, Part Number 04100007C, Revision 1.
6. ATF FRL Laboratory Instruction, Velocity – Differential Pressure, ATF-LS-FRL-LI009.
7. “Installation Guide Model 267 and 267MR Differential Pressure Transducers,” Setra, Boxborough, MA, 2002.
8. McCaffrey, B. J., and Heskestad, G., “A Robust Bidirectional Low-Velocity Probe for Flame and Fire Applications,” Combustion and Flame, 26, 125 – 127, 1976.
9. ATF FRL Technical Reference, Differential Pressure – Point Velocity Probes, ATF-LS-FRL-TR009a.
10. “VOLU-Probe/SS Stainless Steel Pitot Airflow Traverse Probes” AMC Power, Santa Rosa, CA 2007.
11. “Installation Procedure VOLU-probe/1SS for Round Ducts,” Air Monitor Corporation, Santa Rosa, CA.
12. ATF FRL Technical Reference, Differential Pressure – Averaging Velocity Probes, ATF-LS-FRL-TR009b.
13. ATF FRL Laboratory Instruction, Thermocouple, ATF-LS-FRL-LI001.
14. ATF FRL Laboratory Instruction, Optical Density Meter, ATF-LS-FRL-LI014.
15. ATF FRL Technical Reference, Optical Density Meter Fire Products Collector, ATF-LS-FRL-TR014a.
16. ATF FRL Laboratory Instruction, Calibration Burners, ATF-LS-FRL-LI010.
17. ATF FRL Technical Reference, Calibration Burners – Tube Burners, ATF-LS-FRL-TR010b.



ATF-LS-FRL-TR011c - Fire Products Collectors - 4 MW	ID: 5685 Revision: 2
Authority: Technical Leader	Page: 26 of 30
Original maintained by Quality Programs; copies are uncontrolled.	

18. Bryant, A.R., Ohlemiller, T.J., Johnsson, E.L, Hamins, A., Grove, B.S., Guthrie, W.F., Maranghides, A., Mulholland, G.W., “Special Publication 1007,” National Institute of Standards and Technology, Gaithersburg, Maryland, 2003.
19. Taylor, B. N., & Kuyatt, C. E., “NIST Technical Note 1297: Guidelines for Evaluating and Expressing the Uncertainty of NIST Measurement Results,” National Institute of Standards and Technology, Gaithersburg, Maryland, 1993.
20. Guthrie, W. & Liu, H., “Hands-on Workshop on Estimating and Reporting Measurement Uncertainty,” National Institute of Standards and Technology, Gaithersburg, Maryland, Presentation given to the Consumer Product Safety Commission (CPSC), 2007.
21. Babrauskas, V., Grayson, S. ed., *Heat Release in Fires*, E & FN Spon, London, 1992.
22. Kragten, J., “Calculating Standard Deviations and Confidence Intervals with a Universally Applicable Spreadsheet Technique”, *Analyst*, Vol. 119, pp 2161 – 2165, October, 1994.
23. ASTM E2536-09, *Standard Guide for Assessment of Measurement Uncertainty in Fire Tests*, ASTM International, West Conshohocken, Pennsylvania, 2010.
24. Email correspondence from Tim Banham, Test, Service & Support Coordinator, Fire Testing Technology Limited, to Paul Fuss, Fire Research Engineer, ATF Fire Research Laboratory, September 8, 2011.
25. *Allen-Bradley SLC 500™ Analog Input Modules, Catalog Numbers 1746-NI16I and 1746-NI16V – User Manual*, Rockwell Automation, December 1999.
26. Email correspondence from Dr. Sean Gregory, Product Manager, Fire Testing Technology Limited, to Scott Dillon, Fire Research Engineer, ATF Fire research Laboratory, January 15, 2003.
27. Email correspondence from Dr. Sean Gregory, Product Manager, Fire Testing Technology Limited, to Scott Dillon, Fire Research Engineer, ATF Fire research Laboratory, January 17, 2003.
28. ATF FRL Laboratory Instruction, Laboratory Conditions, ATF-LS-FRL-LI017.
29. Fire Research Laboratory Large Scale Calorimeter Velocity Traverses.
30. “Tables of Thermal Properties of Gases”, NBS Circular 564, 1955.
31. Kyle, B. G., “Chemical and Process Thermodynamics”, Englewood Cliffs / Prentice Hall, 1984.



## Appendix A – Experimental Data

Figure 9 shows heat release rate data from a calibration burner experiment conducted under the 4 MW FPC using the natural gas tube burner [17]. The burner was run through a series of 5-minute duration steps with outputs of 0, 50, 100, 300, 500, 700, 900 and 1100 kW. Data from the burner is labeled “Theoretical HRR” in the chart. Calculated HRR from FPC measurements is plotted on the same chart.

Average HRR values were calculated for the burner and FPC during each of the eight steps; the average values are plotted together in Figure 10. This chart shows the average theoretical HRR plotted against the average FPC HRR calculated for each step in Figure 9. The slope of a linear fit through this data is the C-Factor [1].

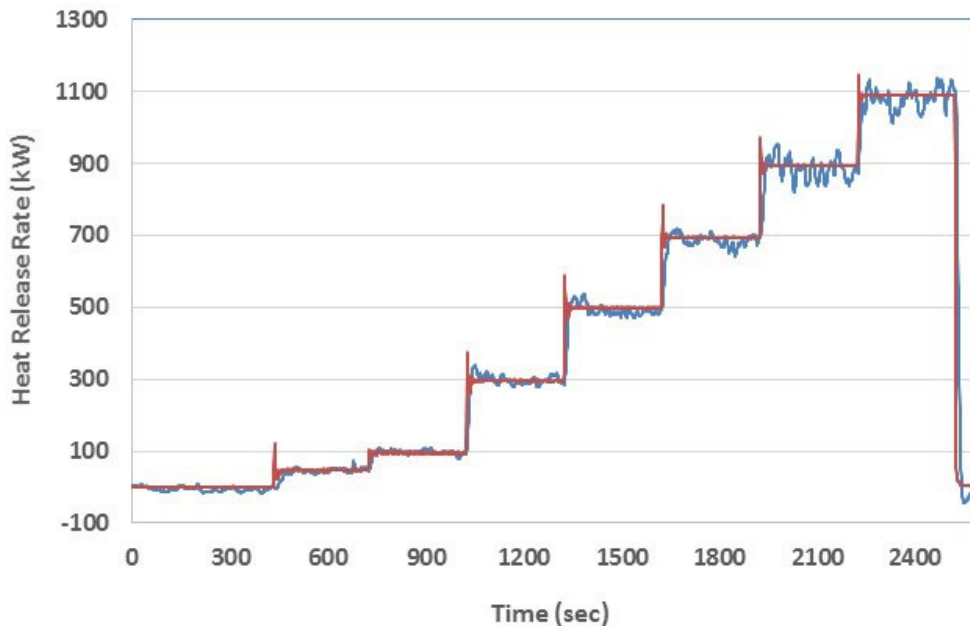

**Figure 9: Heat release rate data from a calibration burner experiment under the 4 MW FPC.**



ATF-LS-FRL-TR011c - Fire Products Collectors - 4 MW	ID: 5685
Authority: Technical Leader	Revision: 2
Page: 28 of 30	
Original maintained by Quality Programs; copies are uncontrolled.	

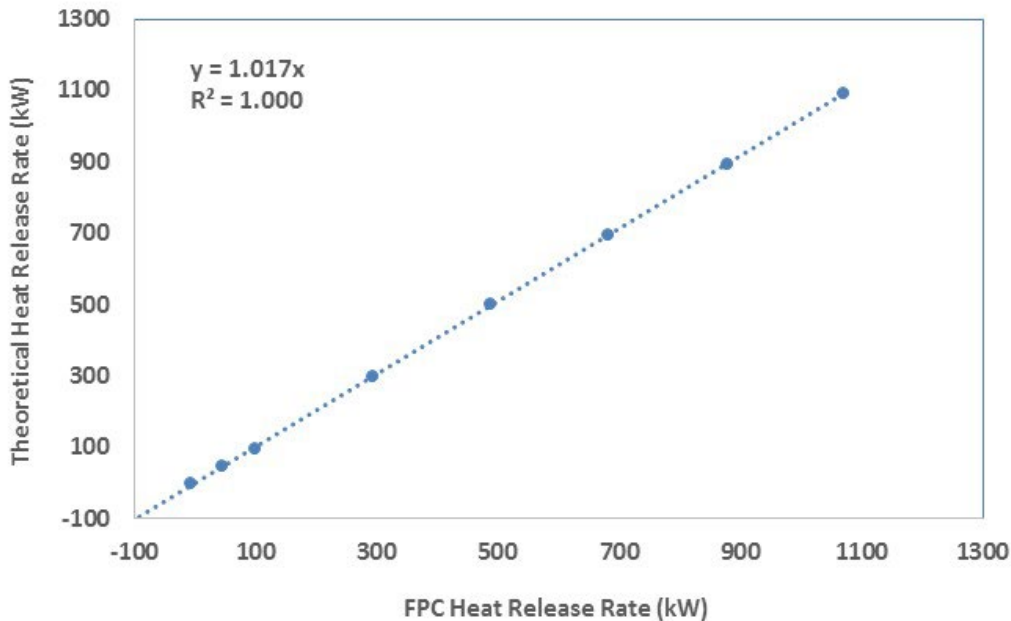

**Figure 10: Average theoretical HRR plotted against average FPC HRR for an experiment using the natural gas tube burner.**

Figure 11 shows heat release rate data from a calibration burner experiment conducted under the 4 MW FPC using the natural gas tube burner [17]. The burner was run through a series of 5-minute duration steps with nominal outputs of 0, 750, 1450, 2450, 3450, 4400 and 5400 kW. Data from the burners is labeled “Theoretical HRR” in the chart. Calculated HRR from FPC measurements is plotted on the same chart.

Average HRR values were calculated for the burner and FPC during each of the seven steps; the average values are plotted together in Figure 12. This chart shows the average theoretical HRR plotted against the average FPC HRR calculated for each step in Figure 11. The slope of a linear fit through this data is the C-Factor [1].

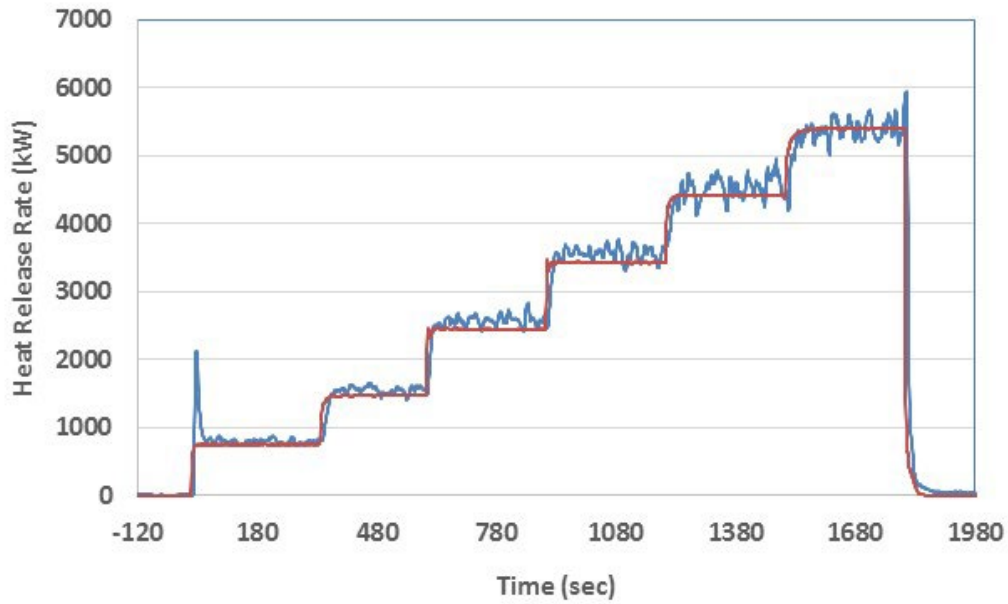

**Figure 11: Heat release rate data from a calibration burner experiment under the 4 MW FPC.**

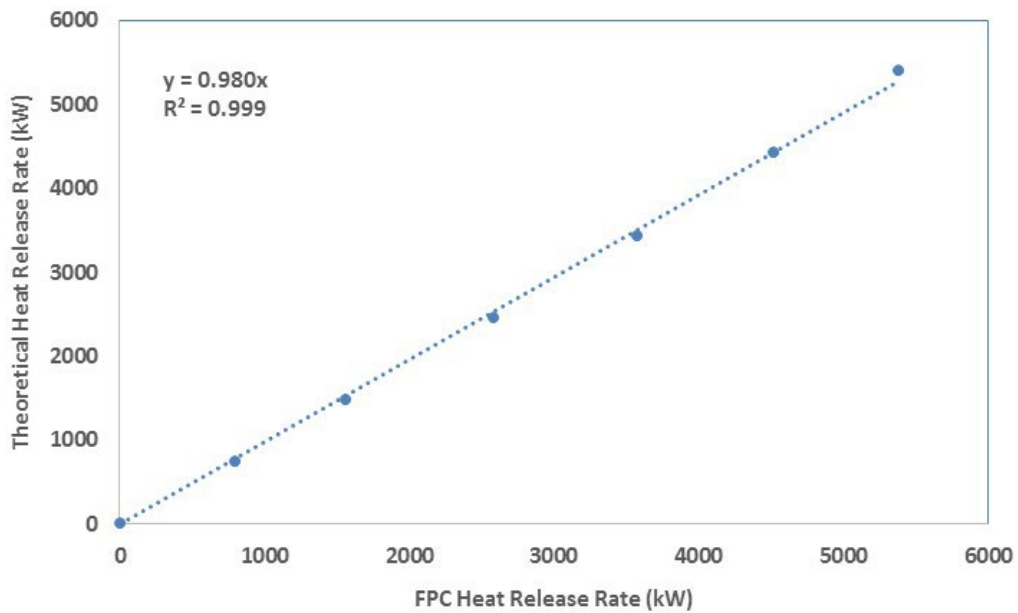

**Figure 12: Average theoretical HRR plotted against average FPC HRR for an experiment using the natural gas tube burner.**



ATF-LS-FRL-TR014A-Optical Density Meter Fire Product Collector	ID: 5687 Revision: 2
Authority: Technical Leader	Page: 1 of 15
Original maintained by Quality Programs; copies are uncontrolled.	

## Scope

This Technical Reference covers the use, design and specifications of white light and laser Optical Density Meters (ODM) in the large scale Fire Product Collectors (FPC) at the Bureau of Alcohol, Tobacco, Firearms and Explosives (ATF) Fire Research Laboratory (FRL).

## Instrument Description

### **GENERAL**

Optical Density Meters (ODMs) are used to perform smoke measurements in the exhaust duct of a fire product collector. Smoke measurements are performed for a variety of reasons including toxicity assessment, visibility calculation, and model validation. Optical density meters measure the attenuation of a light beam passing along a fixed path length through a particulate and gaseous medium. The FPC ODMs used at the ATF FRL are categorized as laser and white light systems.

### **LASER SYSTEM**

The basic elements of the laser system are a laser and two photodiode detectors. The hardware is configured so that the laser and compensating detector are mounted to one side of the FPC duct, while the main detector is mounted on the other side of the duct, directly opposite the laser. A schematic of the setup is shown in Figure 1 (Note that the mounting bracket design may vary). Additional components include beam splitters, diffusers, filter housings, optical density filters, amplifier and power supply modules. The laser system is designed in accordance with ASTM E 1354, NFPA 286 and NFPA 289 fire test standards [1,2,3].



ATF-LS-FRL-TR014A-Optical Density Meter Fire Product Collector	ID: 5687 Revision: 2
Authority: Technical Leader	Page: 2 of 15
Original maintained by Quality Programs; copies are uncontrolled.	

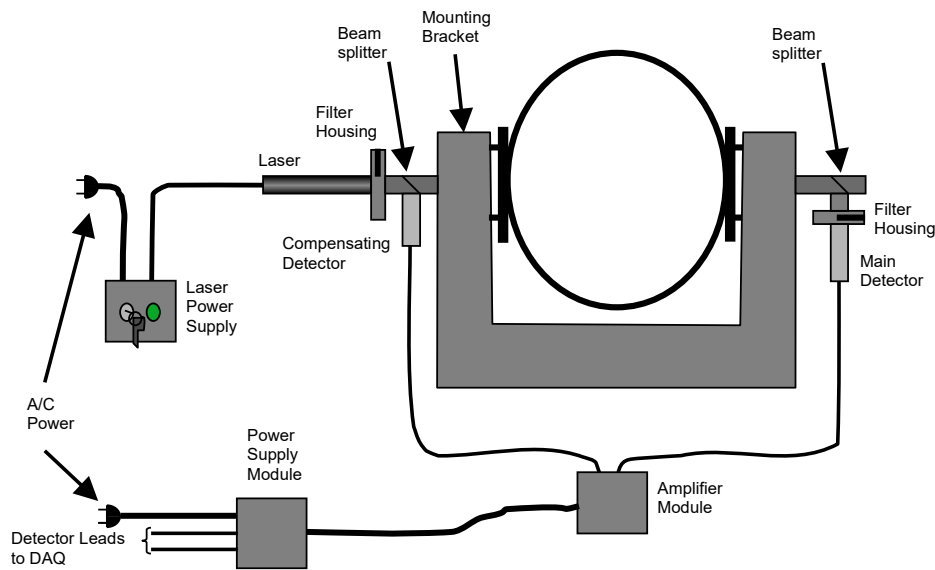

**Figure 1: Layout of laser smoke measurement equipment.**

### Laser

The light source is a 0.5 mW Helium-Neon (HeNe) laser that emits at 632.8 nm (Melles Griot 05-LHP-494-249 or similar) [4]. Figure 2 shows a photo of a typical laser mounted to an assembly that includes a filter housing, beam splitter, diffuser and compensating detector.

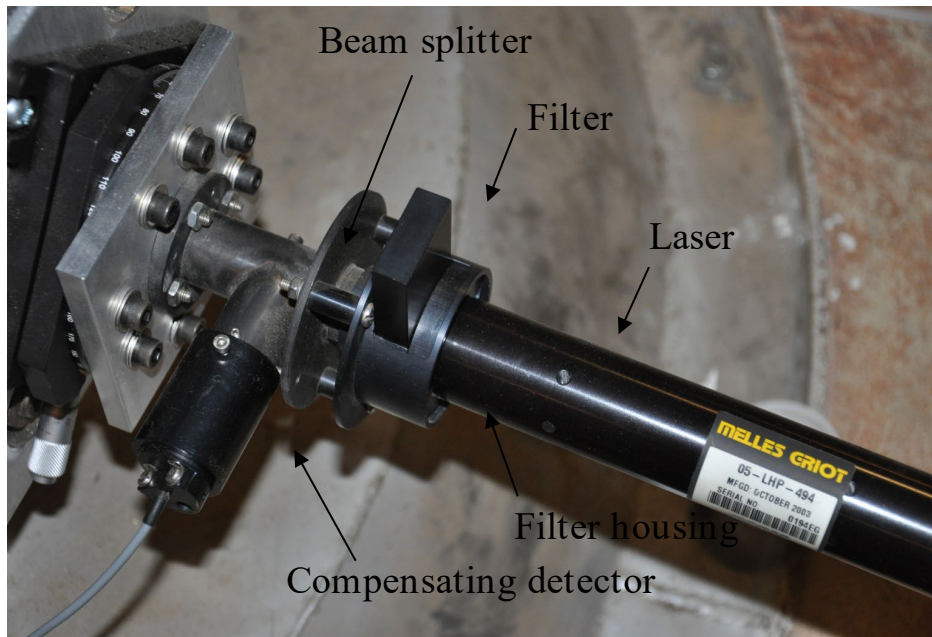

**Figure 2: Laser assembly**



ATF-LS-FRL-TR014A-Optical Density Meter Fire Product Collector	ID: 5687 Revision: 2
Authority: Technical Leader	Page: 3 of 15
Original maintained by Quality Programs; copies are uncontrolled.	

## Detectors

The laser system is equipped with two silicon photodiode detectors: both a main and a compensating (Hamamatsu S1336-44BK) [5]. The main detector is mounted to the side of the duct directly opposite the laser, shown in Figure 3. The signal from the main detector is used to calculate the quantities described in the Lab Instruction [6]. The compensating detector is mounted to the same side of the duct as the laser head (Figure 2). The purpose of a compensating detector is to act as a reference for variations in the laser source intensity so that the main detector signal can be corrected.

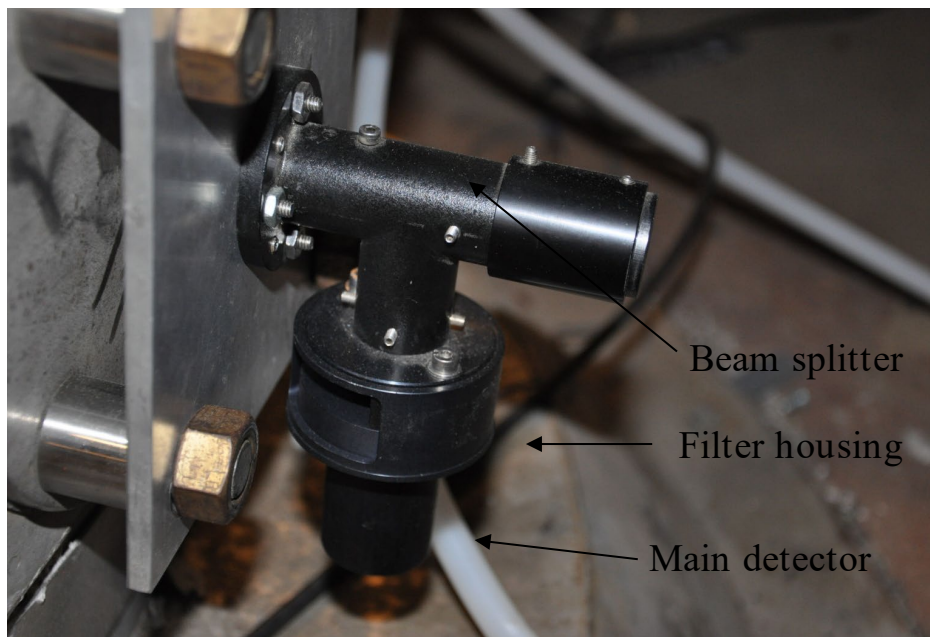

**Figure 3: Main detector assembly**

### Beam Splitter

The system includes two non polarizing cube beam splitters, located along the laser path adjacent to each detector (Melles Griot 03-BSL-043) [7]. Each beam splitter nominally transmits 50% of the incident light, redirecting the remaining light at a 90° angle to the detector.

### Filter Housing

There is a filter housing mounted along the laser path adjacent to both detectors. The filter housings are machined with a slot to accommodate an optical density filter during balancing and calibration procedures. A sliding cover can be used to cover the slot when a filter is not in use.

### Optical Density Filters

Optical density filters can be used to calibrate the laser ODM. Two Coherent neutral density filters (models 36-5338 and 36-5387), with nominal optical densities of 0.3 and 0.8 are provided



ATF-LS-FRL-TR014A-Optical Density Meter Fire Product Collector	ID: 5687 Revision: 2
Authority: Technical Leader	Page: 4 of 15
Original maintained by Quality Programs; copies are uncontrolled.	

[8]. Figure 4 shows a photo of typical filters. In addition to the filters, a blank insert is also provided for use in the system balancing procedure. The laser ODM balancing and calibration procedures are described in the “FireTOSS Calculations” section.

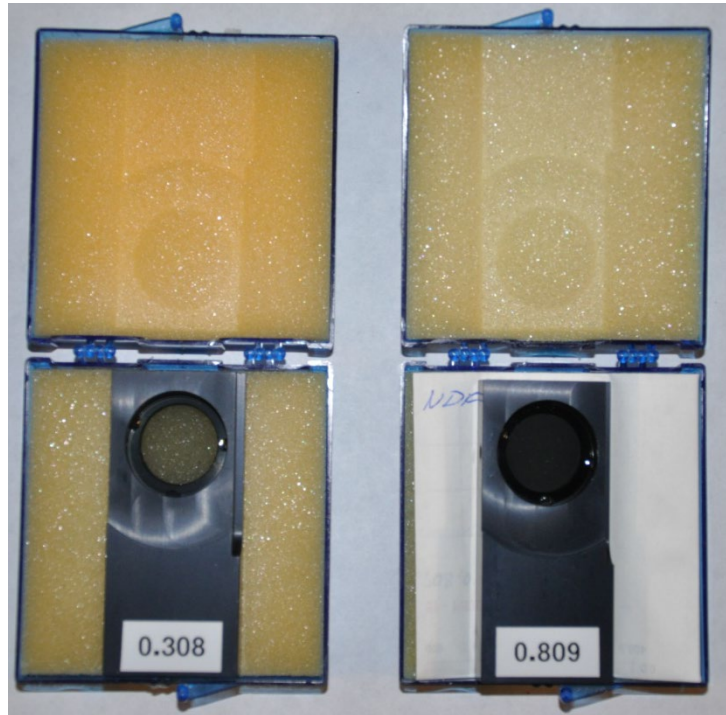

**Figure 4: Optical density filters**

#### Diffuser

The front surface of each detector is covered by a diffuser. The diffuser scatters the incident light over a larger area on the detector surface. This makes system alignment more forgiving but also reduces the light intensity reaching the detector.

#### Amplifier and Power Supply

The detector output is amplified by adjusting the gain on the amplifier module, shown in Figure 5. The power supply module, shown in Figure 6, connects to the amplifier module and also has junctions to connect the detector outputs to the data acquisition system.



**Figure 5: Photodiode amplifier module**



**Figure 6: Laser ODM power supply module**



ATF-LS-FRL-TR014A-Optical Density Meter Fire Product Collector	ID: 5687 Revision: 2
Authority: Technical Leader	Page: 6 of 15
Original maintained by Quality Programs; copies are uncontrolled.	

### WHITE LIGHT

The basic elements of the white light system are a control unit, a light source, and a light receiver. The system used by the FRL is manufactured by Fire Testing Technology (FTT), and conforms to DIN 50055 [9]. The hardware is configured so that the light source is mounted to one side of the FPC duct, while the light receiver is mounted on the other side of the duct, directly opposite the source. A schematic of the setup is shown in Figure 7 (note that the mounting bracket design may vary).

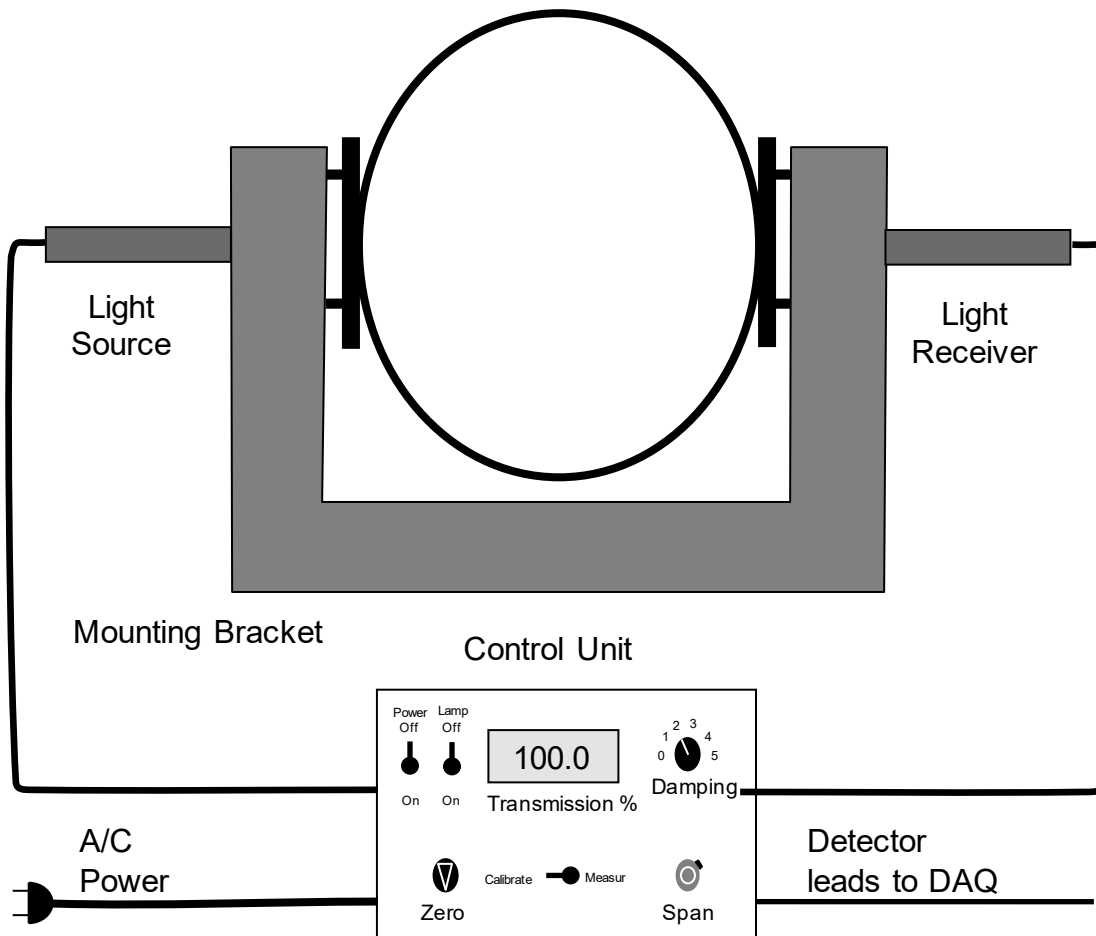

Figure 7: Layout of white light smoke measurement equipment.

#### Control Unit

The control unit interface includes the main power switch, the lamp power switch, the zero and span controls, damping adjustment and a LED display [9]. Figure 8 shows a photo of the control unit. The display can be toggled between calibration mode and measurement mode. The damping setting adjusts the 95% time constant of the amplifier. Table 1 shows the time constant associated with each setting option.



**Figure 8: White light ODM control module**

**Table 1: Damping levels for white light ODM**

Damping Level	Time Constant in s $\pm 10\%$
0	0.75
1	1.6
2	2.5
3	4.0
4	6.0
5	8.0

### Light Source

The light source consists of a halogen lamp and a series of lenses and apertures that combine to create a nearly collimated beam with a 25 mm diameter at the outlet. It is also equipped with an adjustable aperture to reduce the luminous intensity if necessary [9]. Figure 9 shows a photo of the source module.



ATF-LS-FRL-TR014A-Optical Density Meter Fire Product Collector	ID: 5687 Revision: 2
Authority: Technical Leader	Page: 8 of 15
Original maintained by Quality Programs; copies are uncontrolled.	



**Figure 9: Source module for white light ODM**

### Light Receiver

The Light Receiver consists of an achromatic lens system with a focal depth of approximately 80mm and a silicon photoelectric cell in front of which is a spectral filter to accommodate the human eye. A ground glass plate in front of the spectral filter scatters the incident light in the focal plane of the lens. The unit is fitted with an amplifier [9]. Figure 10 shows a photo of the white light receiver module.



**Figure 10: Receiver module for white light ODM**

### Optical Density Filters

Optical density filters can be used to calibrate the laser ODM. Five filters, with nominal optical densities of 0.1, 0.3, 0.5, 1.0 and 2.0 are provided. Figure 11 shows a photo of a typical filter. During a calibration procedure the filter is placed in front of the light receiving module between two guides welded to the mounting frame.



ATF-LS-FRL-TR014A-Optical Density Meter Fire Product Collector	ID: 5687 Revision: 2
Authority: Technical Leader	Page: 9 of 15
Original maintained by Quality Programs; copies are uncontrolled.	



**Figure 11: Filter for white ODM**

## **FireTOSS Calculations**

Optical density meters are used in FPC experiments to calculate the following quantities: extinction coefficient, optical density per meter, rate of smoke release and total smoke released. If an experiment is conducted using a weighing device the smoke yield can also be calculated. The theory behind these calculations is provided elsewhere [6]. The calculations outlined in this document describe how the amplified photodiode and photocell voltages are used to calculate engineering quantities.

## **LASER SYSTEM**

### **Zeroing and Balancing**

The first step in the laser calculation is to zero and balance the system. Zeroing is accomplished by recording the amplified detector outputs with the laser beam blocked; this yields  $V_0$  for each detector ( $V_{0,\text{main}}$  and  $V_{0,\text{comp}}$ ). Likewise, the system is balanced by recording the amplified detector signals with no obstructions in the laser path. This yields  $V_{1,\text{main}}$  and  $V_{1,\text{comp}}$  [10].

The next step is to normalize the amplified detector readings for both the main and compensating detectors to produce a signal that varies between zero and one. The data arrays are normalized according to Equation 1.1:

$$V_n = \frac{V_{\text{raw}} - V_0}{V_1 - V_0} \quad (1.1)$$



ATF-LS-FRL-TR014A-Optical Density Meter Fire Product Collector	ID: 5687 Revision: 2
Authority: Technical Leader	Page: 10 of 15
Original maintained by Quality Programs; copies are uncontrolled.	

Where  $V_{\text{raw}}$  is the detector data array.  $V_n$  is the calculated for the main and compensating detectors to produce  $V_{n,\text{main}}$  and  $V_{n,\text{comp}}$ , respectively.

### Calibration

System calibration is used to calculate the correction factor,  $f$ , used in the extinction coefficient calculation [10]. Calibration is performed on the main detector by placing a neutral density filter in the housing and recording the detector output. The measured optical density is then calculated using Equation 1.2,

$$\text{OD}_{\text{meas}} = \log \left( \frac{V_{n,\text{comp}}}{V_{n,\text{main}}} \right) \quad (1.2)$$

where  $V_{n,\text{main}}$  is calculated based on  $V_{\text{raw}}$  with the filter in place. The correction factor is the ratio of the filter optical density to the measured optical density, as shown in Equation 1.3.

$$f = \frac{\text{OD}_{\text{filter}}}{\text{OD}_{\text{meas}}} \quad (1.3)$$

The factor should be close to 1, and is assumed to be 1 if calibration is not performed.

### Extinction Coefficient

The extinction coefficient,  $k$  ( $\text{m}^{-1}$ ), is defined by Equation 1.4:

$$k = f \cdot \frac{1}{L} \ln \left( \frac{V_{n,\text{comp}}}{V_{n,\text{main}}} \right) \quad (1.4)$$

Where  $L$  is the path length traversed through the attenuating medium. The optical density per meter, rate of smoke release and total smoke released are all derived from the extinction coefficient [6].

### **WHITE LIGHT SYSTEM**

The white light calculations are similar to the laser calculations, with the exception that the signal is not normalized as in Equation 1.1.

### Zeroing and Spanning

The white light FPC ODM is equipped with zero and span controls. The system is zeroed with the light source either blocked or turned off. The system is then spanned with the light source



ATF-LS-FRL-TR014A-Optical Density Meter Fire Product Collector	ID: 5687 Revision: 2
Authority: Technical Leader	Page: 11 of 15
Original maintained by Quality Programs; copies are uncontrolled.	

powered on and unobstructed. The span setting is adjusted such that the display reads 100.0 with no smoke present in the light path.

### Calibration

The system is calibrated by placing three neutral density filters independently in front of the detector, normal to the light path. If the measured transmittance varies from the calibrated filter transmittance by more than 2%, then a correction factor,  $f_w$ , will be used to adjust the measured values.

### Extinction Coefficient

The white extinction coefficient,  $k_w$  ( $m^{-1}$ ) follows from Equation 1.4:

$$k_w = f_w \frac{1}{L} \ln \left( \frac{V_1 - V_0}{V_{raw} - V_0} \right) \quad (1.5)$$

Where  $V_0$  and  $V_1$  are the photocell zero and span voltage, respectively.  $V_{raw}$  is the photocell data array measured during an experiment and  $L$  is the path length traversed through the attenuating medium.

## Uncertainty and Accuracy

The uncertainty of the optical density measurements was estimated using the guidelines of the National Institute of Standards and Technology (NIST) Technical Note 1297 [11], Special Publication 1007 [12], and the NIST Uncertainty Workshop [13]. The combined standard uncertainty of the measurements is a combination of the uncertainty of its components, including voltage, path length and the filter optical density, among other factors, and is given by the following equation:

$$u_c(k) = \sqrt{\sum s_i^2 u(x_i)^2} \quad (1.6)$$

where:

- $u_c(k)$  = Combined standard uncertainty of the extinction coefficient
- $u(x_i)$  = Standard uncertainty of each extinction coefficient component
- $s_i$  = Sensitivity coefficient ( $\partial y / \partial x_i$ )

Due to the relatively large number of variables involved in the laser calculation, a numerical approach was used to evaluate Equation 1.6 [14].

### **LASER**

A spreadsheet formulation was used to apply Equation 1.6 to calculate the combined standard uncertainty in the laser extinction coefficient as represented by Equations 1.1 – 1.4 [14]. The laser extinction coefficient ( $k$ ) is a function of nine variables:



ATF-LS-FRL-TR014A-Optical Density Meter Fire Product Collector	ID: 5687 Revision: 2
Authority: Technical Leader	Page: 12 of 15
Original maintained by Quality Programs; copies are uncontrolled.	

$V_{\text{raw,main}}$	Raw voltage from the main detector (V)
$V_{1,\text{main}}$	Span voltage from the main detector (V)
$V_{0,\text{main}}$	Zero voltage from the main detector (V)
$V_{\text{filter,main}}$	Voltage from the main detector with the filter in place (V)
$V_{\text{raw,comp}}$	Raw voltage from the compensating detector (V)
$V_{1,\text{comp}}$	Span voltage from the compensating detector (V)
$V_{0,\text{comp}}$	Zero voltage from the compensating detector (V)
$OD_{\text{filter}}$	Optical density of the filter (--)
L	Laser path length (m)

The uncertainties in the voltages were estimated based on a statistical evaluation of detector output during an experiment. The standard uncertainty for each measurement was calculated according to Equation (1.7) [13].

$$u = \frac{s}{\sqrt{n}} \quad (1.7)$$

where:

S = Standard deviation of the measurements in a sample  
n = Number of measurements in the sample

Similarly, the combined uncertainty in the path length measurement was based on the resolution of the measuring device and a statistical evaluation based on multiple measurements. The standard uncertainty in the measurement was estimated as  $1.9 \times 10^{-3}$  m.

The uncertainty of the neutral density filters was estimated based on the measured optical density. The filters are calibrated to a tolerance of 0.001 OD. Assuming a rectangular probability distribution the standard uncertainty was calculated by dividing the filter error by  $\sqrt{3}$  [11]. This yields a standard uncertainty for the filters of  $\pm 5.8 \times 10^{-4}$  OD.

The relative combined standard uncertainty in the extinction coefficient is approximately 10.5 % at an extinction coefficient of  $0.01 \text{ m}^{-1}$ . The relative uncertainty decreases rapidly as the extinction coefficient increases, however, falling below 2 % at an extinction coefficient of  $0.05 \text{ m}^{-1}$ . Figure 12 shows a chart of this trend.



ATF-LS-FRL-TR014A-Optical Density Meter Fire Product Collector	ID: 5687 Revision: 2
Authority: Technical Leader	Page: 13 of 15
Original maintained by Quality Programs; copies are uncontrolled.	

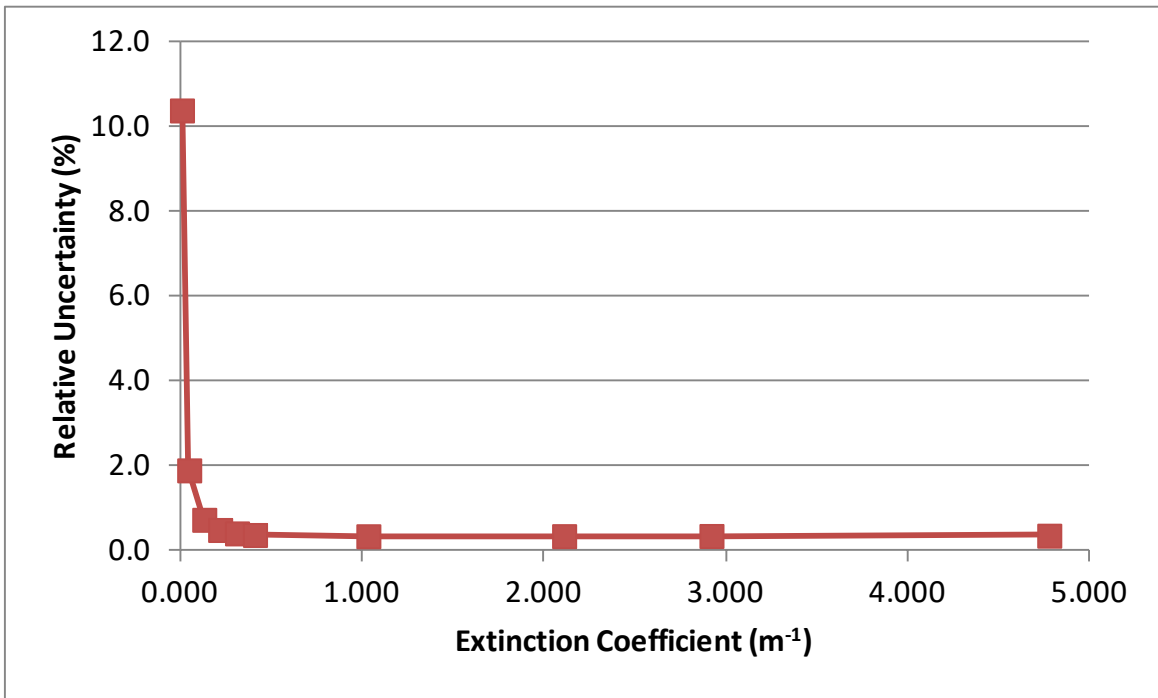

Figure 12: Relative combined standard uncertainty in laser extinction coefficient

### WHITE LIGHT

Uncertainty for the white light system was calculated in a way that was similar to the laser system calculation. A spreadsheet formulation was used to apply Equation 1.6 to calculate the combined standard uncertainty in the extinction coefficient as represented by Equation 1.5 [14].

The uncertainties in the voltages were estimated based on a statistical evaluation of detector output during an experiment. The path length uncertainty was taken to be the same as what was calculated for the laser system.

The filter uncertainty was based on manufacturer specifications. The white light ODM uses UQG Optics neutral density filters. The calibrated accuracy of these filters is  $\pm 1.0\%$  [15]. It can be assumed that this error maintains a rectangular probability distribution and the standard uncertainty was calculated by dividing the filter error by  $\sqrt{3}$  [11].

The relative combined standard uncertainty in the white extinction coefficient displayed a trend similar to the laser system. The relative uncertainty is approximately 12 % for an extinction coefficient of  $6 \times 10^{-4} \text{ m}^{-1}$ . The relative uncertainty decreases rapidly as the extinction coefficient increases, however, falling below 1 % at an extinction coefficient of  $0.01 \text{ m}^{-1}$ . Figure 13 shows a chart of this trend.

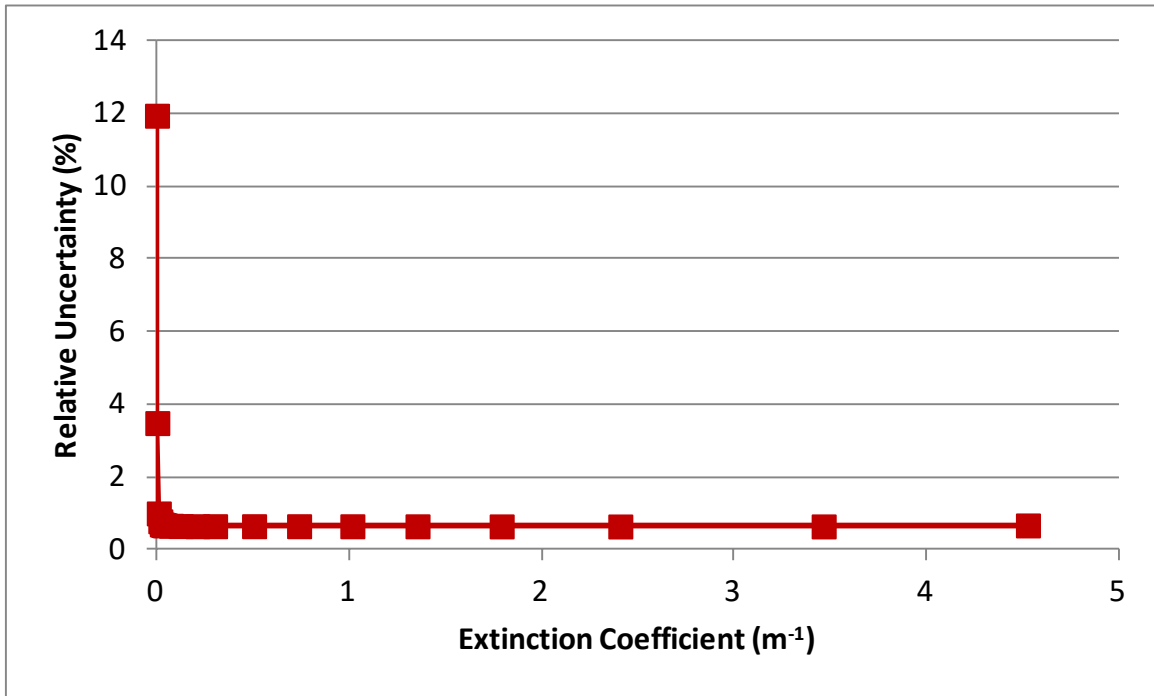

Figure 13: Relative combined standard uncertainty in white extinction coefficient

## References

1. American Society for Testing and Materials, “ASTM E1354: Standard Test Method for Heat and Visible Smoke Release Rates for Materials and Products Using an Oxygen Consumption Calorimeter,” ASTM, West Conshohocken, PA, 2010.
2. National Fire Protection Association, “NFPA 286: Standard Methods of Fire Tests for Evaluating Contribution of Wall and Ceiling Interior Finish to Room Fire Growth,” NFPA, Quincy, MA 2011.
3. National Fire Protection Association, “NFPA 289: Standard Method of Fire Test for Individual Fuel Packages,” NFPA, Quincy, MA 2013.
4. Melles Griot Product Specifications, Model: 05-LHP-494-339 Helium Neon Laser.
5. Product Guide for the S1336 series Si Photodiode, Hamamatsu Solid State Division.
6. ATF FRL Instruction, “Laboratory Instruction LI00014: Optical Density Meter.”



ATF-LS-FRL-TR014A-Optical Density Meter Fire Product Collector	ID: 5687 Revision: 2
Authority: Technical Leader	Page: 15 of 15
Original maintained by Quality Programs; copies are uncontrolled.	

7. Melles Griot Product Catalog, Cube Beamsplitters, pp 23.10 – 23.11
8. Coherent, “Product Catalog – Filters” pg. 261-262.
9. Users’ Guide for the Light Measurement System for Testing Smoke Development, Fire Testing Technology, Ltd., Issue 1.0, 2000.
10. User’s Guide for the Laser Smoke Measurement Unit – For Use with Large Scale Heat Release Systems, Fire Testing Technology, Issue 2.1, 2001.
11. Taylor, B. N., & Kuyatt, C. E., “NIST Technical Note 1297: Guidelines for Evaluating and Expressing the Uncertainty of NIST Measurement Results,” National Institute of Standards and Technology, Gaithersburg, MD, 1993.
12. Bryant, A.R., Ohlemiller, T.J., Johnsson, E.L, Hamins, A., Grove, B.S., Guthrie, W.F., Maranghides, A., Mulholland, G.W., “Special Publication 1007,” National Institute of Standards and Technology, Gaithersburg, MD, 2003.
13. Guthrie, W. & Liu, H., “Hands-on Workshop on Estimating and Reporting Measurement Uncertainty,” National Institute of Standards and Technology, Presentation given to CPSC, 2007.
14. Kragten, J., “Calculating Standard Deviations and Confidence Intervals with a Universally Applicable Spreadsheet Technique”, *Analyst* 119 (10), 2161 – 2165, 1994.
15. UQG Optics, “Calibration Certificate,” Certificate No. CE/510, 2002.



ATF-LS-FRL-TR016A Servomex 4100 Gas Purity Analyzer	ID: 1580 Revision: 4
Authority: Technical Leader	Page: 1 of 4
Original maintained by Quality Programs; copies are uncontrolled.	

## Scope

This Technical Reference covers the use, design and specifications of Servomex 4100 Gas Species Analyzers (Servomex Analyzers) used in the Bureau of Alcohol, Tobacco, Firearms and Explosives (ATF) Fire Research Laboratory (FRL).

## Instrument Description

### **GENERAL**

Servomex analyzers are used in experiments to determine the concentration of a gas species in a mixture of gases. Servomex analyzers are utilized remotely from the measurement location with a continuous sample drawn from the measurement location and pumped through the analyzers via tubing. The sample is pre-treated prior to reaching the analyzers to remove particulate materials and moisture that can damage the analyzers. This pre-treatment is accomplished through a series of particulate filters, cold traps and Drierite filters. To reduce the transit time between the sampling point and the analyzer, a bypass flow is incorporated into the sampling apparatus.

### **ANALYZER DESCRIPTION**

The Servomex analyzer is configured to measure oxygen, carbon monoxide and carbon dioxide. The analyzers feature two different analyzer types, paramagnetic and infrared absorption.

Oxygen (O<sub>2</sub>) measurement utilizes the paramagnetic principle which uses the response of the gas in a varying magnetic field to determine the presence and concentration of a paramagnetic species (oxygen) in the mixture. The paramagnetic analyzer is configured to measure oxygen concentrations of 0-25%. The O<sub>2</sub> measurement is calibrated using nitrogen gas for the zero measurement and ambient air for the high measurement.

Carbon monoxide (CO) and carbon dioxide (CO<sub>2</sub>) measurement utilizes an infrared absorption principle, which measures the absorption of infrared light over a wavelength range to determine the presence and concentration of species, in the mixture. The infrared analyzer is configured to measure CO concentrations of 0-1% and CO<sub>2</sub> concentrations of 0-10%. The CO/CO<sub>2</sub> measurements are calibrated using nitrogen gas for the zero measurements and a 0.8% CO/8% CO<sub>2</sub> gas mixture with a nitrogen balance for the high measurements.



ATF-LS-FRL-TR016A Servomex 4100 Gas Purity Analyzer	ID: 1580 Revision: 4
Authority: Technical Leader	Page: 2 of 4
Original maintained by Quality Programs; copies are uncontrolled.	



**Figure 1: Servomex 4100 Gas Purity Analyzer**

### ***RACK DESCRIPTION***

The Servomex analyzers are located in racks constructed by Fire Testing Technology Limited. The rack includes the analyzer, gas train, pressure and flow control, filtering and moisture removal, power switches, and a mode selection dial which controls how the analyzer measures and calibrates.



**Figure 2. Rack housing of Servomex Analyzer**

### ***DATA ACQUISITION***

Servomex 4100 analyzers produce a current output over the 4-20 mA range. The current output is typically recorded using the FRL's Data Acquisition System (DAQ). To collect the output with a voltage channel, a 250 ohm resistor can be placed in parallel with the signal to convert the output signal to 1-5 volts.



ATF-LS-FRL-TR016A Servomex 4100 Gas Purity Analyzer	ID: 1580 Revision: 4
Authority: Technical Leader	Page: 3 of 4
Original maintained by Quality Programs; copies are uncontrolled.	

## Uncertainty and Accuracy

The uncertainty of the Servomex analyzers was estimated using the guidelines of the National Institute of Standards and Technology (NIST) Technical Note 1297 [1], Special Publication 1007 [2] and the NIST Uncertainty Workshop [3]. Each type of analyzer, which includes the paramagnetic O<sub>2</sub>, infrared CO, and infrared CO<sub>2</sub>, has unique errors. The errors of the gas analyzer at the specified ranges are given by Servomex [4] and are listed in Table 1. Note that most conservative (largest) errors assumed.

**Table 1. Errors associated with the Servomex 4100 Gas Purity Analyzers**

Types of Error	Paramagnetic (O <sub>2</sub> : 0-25%)	Infrared (CO: 0-1%)	Infrared (CO <sub>2</sub> : 0-10%)
Intrinsic Error	<0.15%	0.01%	0.1%
Linearity Error	<0.1%	0.01%	0.1%
Repeatability	<0.1%	0.01%	0.1%
Zero Drift	0.1%	0.02%	0.2%
Span Drift	0.1%	0.01%	0.1%
Output Fluctuation	<0.1%	0.01%	0.1%
Inlet Sample Pressure Effect	<0.5%	<0.03%	<0.3%
Sample Flow Effect	<0.5%	<0.03%	<0.3%

It can be assumed that the errors have a rectangular probability distribution, in which case the standard uncertainty is computed by the following equation [1]:

$$u(x) = \frac{e}{\sqrt{3}} \quad (1.1)$$

where:

$u(x)$  = Standard uncertainty  
 $e$  = Error/accuracy of the measurement

Where more than one type of uncertainty is present for a measurement, the values can be combined in quadrature to achieve a combined uncertainty, using the following equation [1-3]:

$$u_c(X) = \sqrt{\sum u(x_i)^2} \quad (1.2)$$

where:

$u_c(X)$  = Combined standard uncertainty  
 $u(x_i)$  = Standard uncertainty component, as calculated by equation 1.1



ATF-LS-FRL-TR016A Servomex 4100 Gas Purity Analyzer	ID: 1580 Revision: 4
Authority: Technical Leader	Page: 4 of 4
Original maintained by Quality Programs; copies are uncontrolled.	

Using Equation 1.2 with the values from Table 1, the following combined standard uncertainties were calculated:

Paramagnetic (O<sub>2</sub>): 0.44%  
Infrared (CO): 0.03%  
Infrared (CO<sub>2</sub>): 0.30%

## References

1. Taylor, B. N., & Kuyatt, C. E., "NIST Technical Note 1297: Guidelines for Evaluating and Expressing the Uncertainty of NIST Measurement Results," National Institute of Standards and Technology, Gaithersburg, MD, 1993.
2. Bryant, A.R., Ohlemiller, T.J., Johnsson, E.L, Hamins, A., Grove, B.S., Guthrie, W.F., Maranghides, A., Mulholland, G.W., "Special Publication 1007," National Institute of Standards and Technology, Gaithersburg, MD, 2003.
3. Guthrie, W. & Liu, H., "Hands-on Workshop on Estimating and Reporting Measurement Uncertainty," National Institute of Standards and Technology, Presentation given to CPSC, 2007.
4. "4000 Series Analyzer Installation Manual," Servomex, 2005.



ATF-LS-FRL-TR016B Siemens Oxymat 61	ID: 1581 Revision: 4
Authority: Technical Leader	Page: 1 of 5
Original maintained by Quality Programs; copies are uncontrolled.	

## Scope

This Technical Reference covers the use, design and specifications of Siemens Oxymat 61 oxygen analyzers used in the Bureau of Alcohol, Tobacco, Firearms and Explosives (ATF) Fire Research Laboratory (FRL).

## Instrument Description

### GENERAL

Oxygen analyzers are used in experiments to determine the concentration of oxygen in a mixture of gases. Oxygen analyzers are utilized remotely from the measurement location with a continuous sample drawn from the measurement location and pumped through the analyzers via tubing. The sample is pre-treated prior to reaching the analyzers to remove particulate materials and moisture that can damage the analyzers. This pre-treatment is accomplished through a series of filters, cold traps and desiccant filters. To reduce the transit time between the sampling point and the analyzer, a by-pass flow is incorporated into the sampling apparatus.

### ANALYZER DESCRIPTION

The Oxymat 61 utilizes the paramagnetic principle which uses the response of the gas in a varying magnetic field to determine the presence and concentration of a paramagnetic species (oxygen) in the mixture. The paramagnetic analyzer is configured to measure oxygen concentrations of 0-25% [1]. The O<sub>2</sub> measurement is calibrated using zero grade nitrogen gas for the zero measurement and ambient air for the span measurement, which is 20.95%.



Figure 1: Siemens Oxymat 61 Analyzer



ATF-LS-FRL-TR016B Siemens Oxymat 61	ID: 1581 Revision: 4
Authority: Technical Leader	Page: 2 of 5
Original maintained by Quality Programs; copies are uncontrolled.	

### **CART DESCRIPTION**

The Oxymat 61 analyzers are located in mobile carts. The cart includes the analyzer, gas train, pressure and flow control, filtering and moisture removal, power switches, and a gas selection dials which controls how the analyzer measures and calibrates.



**Figure 2. Cart housing of Siemens Oxymat 61 Analyzer**

### **DATA ACQUISITION**

Oxymat 61 analyzers produce a current output over the 4-20 mA range. The current output can be converted to a voltage output by placing a resistor in parallel with the signal. For example, the typical setup used by the FRL is to place a 250 ohm precision resistor in line to convert the output signal to 1-5 VDC.

### **Uncertainty and Accuracy**

ASTM E2536 describes the procedure for assessing uncertainty in fire tests, which is based on the law of propagation of uncertainty [2]. In this approach, the combined standard uncertainty for a calculated output  $y$ , based on a number ( $i$ ) of uncorrelated input quantities  $x_i$ , is a combination of the uncertainty of each component. The standard uncertainties are evaluated independently and combined through an analytical expression for the result. It is expressed mathematically by the following equation [2-5]:

$$u_c(y) = k\sqrt{\sum s_i^2 u(x_i)^2} \quad (0.1)$$

where:



ATF-LS-FRL-TR016B Siemens Oxymat 61	ID: 1581 Revision: 4
Authority: Technical Leader	Page: 3 of 5
Original maintained by Quality Programs; copies are uncontrolled.	

- $u_c(y)$  = Combined standard uncertainty in the output  $y$
- $u(x_i)$  = Standard uncertainty of each component  $x_i$
- $s_i$  = Sensitivity coefficient associated with each component ( $\partial/\partial x_i$ )
- $k$  = Coverage factor

For measurements of time varying data such as temperature, pressure and gas concentration, E2536 identifies three components of error that should be considered: measurement error in the data acquisition system, noise in the recorded signal, and sensor calibration [2]. These are the sources that were considered for present analysis. The following sections provide details related to each component.

### **DATA ACQUISITION UNCERTAINTY**

The FRL uses Yokogawa SMARTDAC+ GM10 data loggers paired with GX90XA I/O modules. The Siemens gas analyzers are typically connected to voltage channels with 6 VDC range. Specifications for the Yokogawa hardware include a calibrated accuracy of 0.01 % of range (6V)  $\pm 2$  mV [6]. The resulting standard uncertainty, assuming a rectangular error distribution, is 1.5 mV.

### **ANALYZER SIGNAL UNCERTAINTY**

The Oxymat 61 produces an analog 4-20 mA signal that is converted to a voltage in the 1-5 VDC range by passing through a 250 ohm resistor. The uncertainty estimate in the recorded analyzer signal included contributions from signal noise (Type A) and error associated with the resistor. The contribution associated with noise in the data came from a statistical analysis of the raw analyzer signal. The contribution from the resistor came from manufacturer specifications.

The standard uncertainty associated with noise in the analyzer signal was estimated using the sample standard deviation [2-5]. Statistics were performed on a data set where the analyzer output was steady for several minutes. The resulting standard uncertainty was 31 ppm, which corresponds to  $\pm 1.9 \mu A$  using scaling for the 0-25% range setting.

To incorporate the uncertainty associated with the resistor, the conversion from current to voltage through Ohm's law was applied:

$$V = I \times R \tag{0.2}$$

where:

- V = Voltage
- I = Current
- R = Resistance



ATF-LS-FRL-TR016B Siemens Oxymat 61	ID: 1581 Revision: 4
Authority: Technical Leader	Page: 4 of 5
Original maintained by Quality Programs; copies are uncontrolled.	

To evaluate the combined uncertainty of the analyzer and resistor, Equation 1.1 was applied to Equation 1.2 (with  $k=1$ ). The combined standard uncertainty in the analyzer voltage,  $u_c(V)$ , is then:

$$u_c(V) = \sqrt{(R)^2(u(I))^2 + (I)^2(u(R))^2} \quad (0.3)$$

The 250 ohm resistor has an accuracy of 0.25 ohm, which corresponds to a standard uncertainty of 0.14 ohm when a rectangular distribution is assumed. For an output of 0.0174 A (corresponding to an ambient  $O_2$  reading in the 0-25% range setting), the combined standard uncertainty in the analyzer is:

$$u_c(V) = \sqrt{(250)^2(0.0000019)^2 + (0.0174)^2(0.14)^2} = \underline{0.0026 V}$$

The standard uncertainties in the data acquisition system and the analyzer are combined through the root sum squared (RSS) method [2,3,5]:

$$u_c = \sqrt{(0.0015)^2 + (0.0026)^2} = 3$$

### **CALIBRATION UNCERTAINTY**

The Siemens Oxymat 61 is equipped with a paramagnetic cell that produces a linear output. A two point calibration is performed daily using zero and span gases. The zero gas is “Zero” grade (99.99 %) bottled nitrogen. Assuming a rectangular distribution, the standard uncertainty of the zero gas is  $\pm 5.8 \times 10^{-5}$  mol/mol. Laboratory air is used to span the oxygen analyzer; the concentration is taken as 20.95 %. The uncertainty associated with the oxygen span concentration is estimated to be 0.05 %  $O_2$  [4]. This estimate was verified through a comparison with a high purity certified  $O_2/N_2$  mixture.

The oxygen concentration is calculated from the following relationship:

$$X_{O_2} = m_{O_2} * V_{O_2} + b_{O_2} \quad (0.4)$$

Where  $V_{O_2}$  is the measured voltage and  $m_{O_2}$  and  $b_{O_2}$  are the calibration coefficients:

$$m_{O_2} = \frac{X_{O_2span} - X_{O_2zero}}{V_{O_2span} - V_{O_2zero}} \quad (0.5)$$

and

$$b_{O_2} = X_{O_2zero} + m_{O_2} * V_{O_2zero} \quad (0.6)$$



ATF-LS-FRL-TR016B Siemens Oxymat 61	ID: 1581 Revision: 4
Authority: Technical Leader	Page: 5 of 5
Original maintained by Quality Programs; copies are uncontrolled.	

These combine to the following:

$$X_{O_2} = \frac{X_{O_2span} - X_{O_2zero}}{V_{O_2span} - V_{O_2zero}} * (V_{O_2} - V_{O_2zero}) + X_{O_2zero} \quad (0.7)$$

Equation 1.1 is applied to Eqn. 1.7 to calculate the combined expanded uncertainty in the oxygen mole fraction,  $u(X_{O_2})$ . Due to algebraic complexity of the resulting expression, the calculation was performed using a spreadsheet method [7]. Using the standard uncertainties derived in this analysis, and assuming a coverage factor of  $k=1$ , the combined uncertainty is 0.06%  $O_2$ , or approximately 560 ppm.

## References

1. "Oxymat 61: The Analyzer for Standard Applications Manual," Siemens, 2001.
2. ASTM E2536-09, *Standard Guide for Assessment of Measurement Uncertainty in Fire Tests*, ASTM International, West Conshohocken, Pennsylvania, 2015.
3. Taylor, B. N., & Kuyatt, C. E., "NIST Technical Note 1297: Guidelines for Evaluating and Expressing the Uncertainty of NIST Measurement Results," National Institute of Standards and Technology, Gaithersburg, MD, 1993.
4. Bryant, A.R., Ohlemiller, T.J., Johnsson, E.L, Hamins, A., Grove, B.S., Guthrie, W.F., Maranghides, A., Mulholland, G.W., "Special Publication 1007," National Institute of Standards and Technology, Gaithersburg, MD, 2003.
5. Guthrie, W. & Liu, H., "Hands-on Workshop on Estimating and Reporting Measurement Uncertainty," National Institute of Standards and Technology, Presentation given to CPSC, 2007.
6. "SMARTDAC+ Data Acquisition and Control, Data Acquisition System GM," Yokogawa, 2014
7. Kragten, J., "Calculating Standard Deviations and Confidence Intervals with a Universally Applicable Spreadsheet Technique", *Analyst*, Vol. 119, pp 2161 – 2165, October, 1994.



ATF-LS-FRL-TR016C Siemens Ultramat 23	ID: 158282 Revision: 4
Authority: Technical Leader	Page: 1 of 6
Original maintained by Quality Programs; copies are uncontrolled.	

## Scope

This Technical Reference covers the use, design and specifications of Siemens Ultramat 23 gas analyzers used in the Bureau of Alcohol, Tobacco, Firearms and Explosives (ATF) Fire Research Laboratory (FRL).

## Instrument Description

### GENERAL

Carbon Monoxide/Carbon Dioxide (CO/CO<sub>2</sub>) analyzers are used in experiments to determine the concentration of CO and CO<sub>2</sub> in a mixture of gases. CO/CO<sub>2</sub> analyzers are utilized remotely from the measurement location with a continuous sample drawn from the measurement location and pumped through the analyzers via tubing. The sample is pre-treated prior to reaching the analyzers to remove particulate materials and moisture that can damage the analyzers. This pre-treatment is accomplished through a series of soot filters, cold traps and desiccant filters. To reduce the transit time between the sampling point and the analyzer, a by-pass flow is incorporated into the sampling apparatus.

### ANALYZER DESCRIPTION

The Ultramat 23 utilizes an infrared absorption principle, which measures the absorption of infrared light over a wavelength range to determine the presence and concentration of species, in the mixture. The infrared analyzer is configured to measure CO concentrations of 0-5% and CO<sub>2</sub> concentrations of 0-25%. [1] The CO/CO<sub>2</sub> measurements are calibrated using zero grade nitrogen gas for the zero measurements and a 4.5% CO/22.5% CO<sub>2</sub> gas mixture for the span measurements.



**Figure 1: Siemens Ultramat 23 Analyzer**



ATF-LS-FRL-TR016C Siemens Ultramat 23	ID: 158282 Revision: 4
Authority: Technical Leader	Page: 2 of 6
Original maintained by Quality Programs; copies are uncontrolled.	

### ***CART DESCRIPTION***

The Ultramat 23 analyzers are located in mobile carts. The cart includes the analyzer, gas train, pressure and flow control, filtering and moisture removal, power switches, and a gas selection dials which controls how the analyzer measures and calibrates.



**Figure 2. Cart housing of Siemens Ultramat 23 Analyzer**

### ***DATA ACQUISITION***

Ultramat analyzers produce a current output of 4-20 mA. The current output can be converted to a voltage output by placing a resistor in parallel with the signal. For example, the typical setup used by the FRL is to place a 250 ohm resistor in parallel to convert the output signal to 1-5 volts.

### **Uncertainty and Accuracy**

ASTM E2536 describes the procedure for assessing uncertainty in fire tests, which is based on the law of propagation of uncertainty [2]. In this approach, the combined standard uncertainty for a calculated output  $y$ , based on a number ( $i$ ) of uncorrelated input quantities  $x_i$ , is a combination of the uncertainty of each component. The standard uncertainties are evaluated independently and combined through an analytical expression for the result. It is expressed mathematically by the following equation [2-5]:

$$u_c(y) = k\sqrt{\sum s_i^2 u(x_i)^2} \quad (0.1)$$

where:



ATF-LS-FRL-TR016C Siemens Ultramat 23	ID: 158282 Revision: 4
Authority: Technical Leader	Page: 3 of 6
Original maintained by Quality Programs; copies are uncontrolled.	

- $u_c(y)$  = Combined standard uncertainty in the output y
- $u(x_i)$  = Standard uncertainty of each component  $x_i$
- $s_i$  = Sensitivity coefficient associated with each component ( $\partial/\partial x_i$ )
- k = Coverage factor

For measurements of time varying data such as temperature, pressure, and gas concentration, E2536 identifies three components of error that should be considered: measurement error in the data acquisition system, noise in the recorded signal, and sensor calibration [2]. These are the sources that were considered for present analysis. The following sections provide details related to each component.

### **DATA ACQUISITION UNCERTAINTY**

The FRL uses Yokogawa SMARTDAC+ GM10 data loggers paired with GX90XA I/O modules. The Siemens gas analyzers are typically connected to voltage channels with 6 VDC range. Specifications for the Yokogawa hardware include a calibrated accuracy of 0.01 % of range (6V)  $\pm 2$  mV [6]. The resulting standard uncertainty, assuming a rectangular error distribution, is 1.5 mV.

### **ANALYZER SIGNAL UNCERTAINTY**

The Ultramat 23 produces analog 4-20 mA signals that are converted to voltage in the 1-5 VDC range by passing through a 250 ohm resistor. The uncertainty estimate in the recorded analyzer signal included contributions from signal noise (Type A) and error associated with the resistor. The contribution associated with noise in the data came from a statistical analysis of the raw analyzer signal. The contribution from the resistor came from manufacturer specifications.

The standard uncertainty associated with noise in the analyzer signal was estimated using the sample standard deviation [2-5]. Statistics were performed on a data set where the analyzer output was steady for several minutes. The resulting standard uncertainties were 12 ppm for CO and 37 ppm for CO<sub>2</sub> which correspond to  $\pm 3.8 \mu A$  and  $\pm 2.3 \mu A$ , respectively, using scaling for the typical range settings.

To incorporate the uncertainty associated with the resistor, the conversion from current to voltage through Ohm's law was applied:

$$V = I \times R \tag{0.2}$$

where:

- V = Voltage
- I = Current
- R = Resistance



ATF-LS-FRL-TR016C Siemens Ultramat 23	ID: 158282 Revision: 4
Authority: Technical Leader	Page: 4 of 6
Original maintained by Quality Programs; copies are uncontrolled.	

To evaluate the combined uncertainty of the analyzer and resistor, Eqn. 1.1 was applied to Eqn. 1.2 (with  $k=1$ ). The combined standard uncertainty in the analyzer voltage,  $u_c(V)$ , is then:

$$u_c(V) = \sqrt{(R)^2(u(I))^2 + (I)^2(u(R))^2} \quad (0.3)$$

The 250 ohm resistor has an accuracy of 0.25 ohm, which corresponds to a standard uncertainty of 0.14 ohm when a rectangular distribution is assumed. For ambient concentrations and typical range settings (0 – 5% for CO and 0 – 25% for CO<sub>2</sub>), the combined standard uncertainty in the analyzer is 1.1 mV and 0.8 mV for CO and CO<sub>2</sub>, respectively.

The standard uncertainties in the data acquisition system and the analyzer are combined through the root sum squared (RSS) method [2, 3, 5]. For CO the result is:

$$u_c = \sqrt{(0.0015)^2 + (0.0008)^2} = \underline{1.9 \text{ mV}}$$

Similarly, for CO<sub>2</sub> the result is 1.7 mV.

### **CALIBRATION UNCERTAINTY**

The Siemens Ultramat 23 is equipped with non-dispersive infrared (NDIR) cells that produce a linear output. A two point calibration is performed daily using zero and span gases. The zero gas is “Zero” grade (99.99 %) bottled nitrogen. Assuming a rectangular distribution, the standard uncertainty of the zero gas is  $\pm 5.8 \times 10^{-5}$  mol/mol. The span gas is typically a blend consisting nominally of 22.5% CO<sub>2</sub>, 8% CO with the balance nitrogen. For a primary standard mixture, the standard uncertainties in the CO<sub>2</sub> and CO are 0.012 % and 0.005 %, respectively.

The gas concentration is calculated from the following relationship:

$$X_i = m_i * V_i + b_i \quad (0.4)$$

Where  $i$  represents CO or CO<sub>2</sub>,  $V_i$  is the measured voltage and  $m_i$  and  $b_i$  are the calibration coefficients:

$$m_i = \frac{X_{i\text{span}} - X_{i\text{zero}}}{V_{i\text{span}} - V_{i\text{zero}}} \quad (0.5)$$

and

$$b_i = X_{i\text{zero}} + m_i * V_{i\text{zero}} \quad (0.6)$$



ATF-LS-FRL-TR016C Siemens Ultramat 23	ID: 158282 Revision: 4
Authority: Technical Leader	Page: 5 of 6
Original maintained by Quality Programs; copies are uncontrolled.	

These combine to the following:

$$X_i = \frac{X_{i_{span}} - X_{i_{zero}}}{V_{i_{span}} - V_{i_{zero}}} * (V_i - V_{i_{zero}}) + X_{i_{zero}} \quad (0.7)$$

Equation 1.1 is applied to Eqn. 1.7 to calculate the combined expanded uncertainty in the mole fraction,  $u(X_i)$ . Due to algebraic complexity of the resulting expression, the calculation was performed using a spreadsheet method [7]. Using the standard uncertainties derived in this analysis, and assuming a coverage factor of  $k=1$ , the combined uncertainties for are 0.053 % CO and 0.052 % CO<sub>2</sub>, or approximately 530 ppm and 520 ppm, respectively.



ATF-LS-FRL-TR016C Siemens Ultramat 23	ID: 158282 Revision: 4
Authority: Technical Leader	Page: 6 of 6
Original maintained by Quality Programs; copies are uncontrolled.	

## References

1. "Ultramat 23: Gas Analyzers for IR-Absorbing Gases and Oxygen Manual, Operating Instructions," Siemens, 2005.
2. ASTM E2536-09, *Standard Guide for Assessment of Measurement Uncertainty in Fire Tests*, ASTM International, West Conshohocken, Pennsylvania, 2015.
3. Taylor, B. N., & Kuyatt, C. E., "NIST Technical Note 1297: Guidelines for Evaluating and Expressing the Uncertainty of NIST Measurement Results," National Institute of Standards and Technology, Gaithersburg, MD, 1993.
4. Bryant, A.R., Ohlemiller, T.J., Johnsson, E.L, Hamins, A., Grove, B.S., Guthrie, W.F., Maranghides, A., Mulholland, G.W., "Special Publication 1007," National Institute of Standards and Technology, Gaithersburg, MD, 2003.
5. Guthrie, W. & Liu, H., "Hands-on Workshop on Estimating and Reporting Measurement Uncertainty," National Institute of Standards and Technology, Presentation given to CPSC, 2007.
6. "SMARTDAC+ Data Acquisition and Control, Data Acquisition System GM," Yokogawa, 2014
7. Kragten, J., "Calculating Standard Deviations and Confidence Intervals with a Universally Applicable Spreadsheet Technique", *Analyst*, Vol. 119, pp 2161 – 2165, October, 1994.



ATF-LS-FRL-TR019B Sartorius Scale-450 kg - Technical Reference	ID: 2138 Revision: 6
Authority: Technical Leader	Page: 1 of 4
Original maintained by Quality Programs; copies are uncontrolled.	

## Scope

This Technical Reference covers the use, design and specifications of the Sartorius-Scale-450 kg scale used in the Bureau of Alcohol, Tobacco, Firearms and Explosives (ATF) Fire Research Laboratory (FRL).

## Instrument Description

### **GENERAL**

The Sartorius-Scale-450 kg weighing device is used primarily for mass measurements up to a capacity of 450 kg (1000 lb<sub>m</sub>). This scale offers a modular design incorporating the use of four load cells, a weighing platform, and an indicator unit. The components of Sartorius-Scale-450 kg weighing device are calibrated as one unit in accordance with manufacturer and ATF specifications.

### Load Cell

The Sartorius-Scale-450 kg uses four load cells (GWT Type 011462/500 lb) each with a capacity of 225 kg (500 lb<sub>m</sub>). Two load cells are loaded in compression and two load cells are loaded in tension, allowing for a maximum measurement capacity of 450 kg (1000 lb<sub>m</sub>). The load cells respond to an applied load positioned on a weighing platform and relays an electrical response to a Sartorius model PR6130 Cable Junction Box. The responses from the four load cells are then combined into a single analog electrical signal and transmitted to the indicator unit.

### Weighing Platform

The Sartorius-Scale-450 kg uses a Sartorius model CAPPU-1000KK-LU weighing platform with a 91.4 cm x 91.4 cm (36 inch x 36 inch) steel load plate. The platform must be leveled manually by the user prior to testing to reduce measurement errors caused by the angular orientation of the scale. Adjusting the supports on each of the corners of the weighing platform raises or lowers each corner if the scale is used on an uneven surface.

### Indicator

The Sartorius-Scale-450 kg uses a Sartorius Combics 3 model CIS3-U indicator unit to provide a digital display of the analog electrical output signal from the load cells. The indicator offers a maximum readability of 0.02 kg (0.05 lb<sub>m</sub>) at a 450 kg (1000 lb<sub>m</sub>) capacity. The indicator also contains functions that zero, tare, and offset mass measurements to the full capacity defined by the indicator.



ATF-LS-FRL-TR019B Sartorius Scale-450 kg - Technical Reference	ID: 2138 Revision: 6
Authority: Technical Leader	Page: 2 of 4
Original maintained by Quality Programs; copies are uncontrolled.	

## **CONNECTING TO THE DATA ACQUISITION**

The Sartorius Combics 3 indicator allows for transmitting data to the data acquisition (DAQ) system by means of a network cable connected to a FireTOSS jack.

## **Uncertainty**

The measurement uncertainty was determined using guidelines in the National Institute of Standards and Technology (NIST) Technical Note 1297 [1], Special Publication 1007 [2], and the NIST Uncertainty Workshop [3]. The uncertainty of mass measurements includes the allowable uncertainty, random uncertainty, and combined uncertainty.

## **ALLOWABLE UNCERTAINTY**

The allowable uncertainty is determined from allowable tolerances provided in the manufacturer's specifications [4] and NIST Handbook 44 [5]. The allowable tolerances defined by the manufacturer are:

- the linearity as  $\pm 0.05$  kg (0.1 lb<sub>m</sub>)
- the repeatability as  $\pm 0.07$  kg (0.15 lb<sub>m</sub>)

Additional tolerance requirements for the weighing device provided by NIST Handbook 44 are:

- the tolerance as  $\pm 0.23$  kg (0.5 lb<sub>m</sub>)
- the zero balance as  $\pm 0.23$  kg (0.5 lb<sub>m</sub>)
- the sensitivity as  $\pm 0.05$  kg (0.1 lb<sub>m</sub>)
- the temperature effect on the minimum dead load output as  $\pm 0.02$  kg (0.05 lb<sub>m</sub>) over a temperature change of 5°C (9°F)

The error associated with each tolerance,  $T$ , assumes a rectangular probably distribution and can be calculated by dividing the tolerance by  $\sqrt{3}$  [1]. The allowable uncertainty,  $U_A$ , can be calculated by combining the error components in quadrature using Equation 1.1.

$$U_A = \sqrt{\sum \left(\frac{T}{\sqrt{3}}\right)^2} \quad (1.1)$$

The allowable uncertainty for the weighing device is  $\pm 0.19$  kg ( $\pm 0.43$  lb<sub>m</sub>) or  $\pm 0.04$  % of a 450 kg (1000 lb<sub>m</sub>) capacity.



ATF-LS-FRL-TR019B Sartorius Scale-450 kg - Technical Reference	ID: 2138 Revision: 6
Authority: Technical Leader	Page: 3 of 4
Original maintained by Quality Programs; copies are uncontrolled.	

### ***RANDOM UNCERTAINTY***

The random uncertainty,  $U_R$ , is determined from random errors that occur naturally during operation. The errors are determined using sample measurements taken during typical test conditions. The random uncertainty is calculated by applying the standard deviation,  $S$ , and the number of measurements,  $n$ , in a sample to Equation 1.2.

$$U_R = \frac{S}{\sqrt{n}} \quad (1.2)$$

The random uncertainty is based on a sample containing 600 measurements of a 90 kg (200 lb<sub>m</sub>) mass. The random uncertainty for the weighing device is ± 0.00 kg (0.00 lb<sub>m</sub>) or 0 % of a 450 kg (1000 lb<sub>m</sub>) capacity.

### ***COMBINED UNCERTAINTY***

The combined uncertainty,  $U_C$ , is determined from the combining the allowable uncertainty and random uncertainty in quadrature. The combined uncertainty is calculated using Equation 1.3.

$$U_C = \sqrt{(U_A^2 + U_R^2)} \quad (1.3)$$

The combined uncertainty for the weighing device is ± 0.19 kg (± 0.43 lb<sub>m</sub>) or ± 0.04 % of a 450 kg (1000 lb<sub>m</sub>) capacity.

### **References**

1. Taylor, B. N., & Kuyatt, C. E., “NIST Technical Note 1297: Guidelines for Evaluating and Expressing the Uncertainty of NIST Measurement Results,” National Institute of Standards and Technology, Gaithersburg, MD, 1993.
2. Bryant, A.R., Ohlemiller, T.J., Johnson, E.L, Hamins, A., Grove, B.S., Guthrie, W.F., Maranghides, A., Mulholland, G.W., “Special Publication 1007,” National Institute of Standards and Technology, Gaithersburg, MD, 2003.
3. Guthrie, W. & Liu, H., “Hands-on Workshop on Estimating and Reporting Measurement Uncertainty,” National Institute of Standards and Technology, Presentation given to CPSC, 2007.



ATF-LS-FRL-TR019B Sartorius Scale-450 kg - Technical Reference	ID: 2138 Revision: 6
Authority: Technical Leader	Page: 4 of 4
Original maintained by Quality Programs; copies are uncontrolled.	

- 
4. McGovern, M., "Sartorius\_CAPP4U-1000KK-LU\_Loadcell\_GWT011462.xls", Sartorius AG, February 17, 2011
  5. "Handbook 44: Specifications, Tolerances, and Other Technical Requirements for Weighing Devices," National Institute of Standards and Technology, Gaithersburg, MD, 2010.



ATF-LS-FRL-TR019I Sartorius Scale-30 kg - Technical Reference	ID: 4249 Revision: 4
Authority: Technical Leader	Page: 1 of 4
Original maintained by Quality Programs; copies are uncontrolled.	

## Scope

This Technical Reference covers the use, design and specifications of the Sartorius-Scale-30 kg scale used in the Bureau of Alcohol, Tobacco, Firearms and Explosives (ATF) Fire Research Laboratory (FRL).

## Instrument Description

### **GENERAL**

The Sartorius-Scale-30 kg weighing device is used primarily for mass measurements up to a capacity of 30 kg (60 lb<sub>m</sub>). This scale offers a modular design incorporating the use of a load cell, a weighing platform, and an indicator unit. The components of Sartorius-Scale-30 kg weighing device are calibrated as one unit in accordance with manufacturer and ATF specifications.

### Load Cell

The Sartorius-Scale-30 kg uses one Sartorius load cell (model 03167124) with a capacity of 30 kg (60 lb<sub>m</sub>). The load cell responds to an applied load positioned on a weighing platform and relays an electrical response to a junction box with amplifier. The electrical signal is then transmitted to the indicator unit.

### Weighing Platform

The Sartorius-Scale-30 kg uses a Sartorius model CAPP1U-50DD-LU weighing platform with a 45.7 cm x 45.7 cm (18 inch x 18 inch) stainless steel load plate. The platform is NEM4/IP65 to withstand everyday washdown environments. The platform must be leveled manually by the user prior to testing to reduce measurement errors caused by the angular orientation of the scale. Adjusting the supports on each of the corners of the weighing platform raises or lowers each corner if the scale is used on an uneven surface.

### Indicator

The Sartorius-Scale-30 kg uses a Sartorius Combics 2 Model CAISL2-U indicator unit to provide a digital display of the analog electrical output signal from the load cell. The indicator offers a maximum readability of 0.001 kg (0.002 lb<sub>m</sub>) at a 30 kg (60 lb<sub>m</sub>) capacity. The indicator also contains functions that zero, tare, and offset mass measurements to the full capacity defined by the indicator.

## **CONNECTING TO THE DATA ACQUISITION**

The Sartorius Combics 2 indicator allows for transmitting data to the data acquisition (DAQ) system by means of a network cable connected to a FireTOSS jack.



ATF-LS-FRL-TR019I Sartorius Scale-30 kg - Technical Reference	ID: 4249 Revision: 4
Authority: Technical Leader	Page: 2 of 4
Original maintained by Quality Programs; copies are uncontrolled.	

## Uncertainty

The uncertainty of the mass measurements was estimated using the guidelines of the National Institute of Standards and Technology (NIST) Technical Note 1297 [1], Special Publication 1007 [2], and the NIST Uncertainty Workshop [3]. The uncertainty of mass measurements includes the allowable uncertainty, random uncertainty, and combined uncertainty.

### **ALLOWABLE UNCERTAINTY**

The allowable uncertainty is determined from allowable tolerances provided in the manufacturer's specifications and NIST Handbook 44. The allowable tolerances defined by the manufacturer [4] are:

- the linearity as  $\pm 0.0045$  kg (0.01 lb<sub>m</sub>)
- the span as  $\pm 0.0045$  kg (0.01 lb<sub>m</sub>)
- the off-center load eccentricity as  $\pm 0.0091$  kg (0.02 lb<sub>m</sub>)
- the reproducibility as  $\pm 0.0045$  kg (0.01 lb<sub>m</sub>)

Additional tolerance requirements for the weighing device provided by NIST Handbook 44 [5] are:

- the tolerance as  $\pm 0.0025$  kg (0.0055 lbm)
- the zero balance as  $\pm 0.0015$  kg (0.0331 lbm)
- the sensitivity as  $\pm 0.0010$  kg (0.0022 lbm)
- the temperature effect on the minimum dead load output as  $\pm 0.0005$  kg (0.0011 lbm) over a temperature change of 5°C (9°F)

The error associated with each tolerance,  $T$ , assumes a rectangular probably distribution and can be calculated by dividing the tolerance by  $\sqrt{3}$  [1]. The allowable uncertainty,  $U_A$ , can be calculated by combining the error components in quadrature using Equation 1.1.

$$U_A = \sqrt{\sum \left(\frac{T}{\sqrt{3}}\right)^2} \quad (1.1)$$

The allowable uncertainty for the weighing device is  $\pm 0.0112$  kg (0.0247 lb<sub>m</sub>) or  $\pm 0.04\%$  of a 30 kg capacity.



ATF-LS-FRL-TR019I Sartorius Scale-30 kg - Technical Reference	ID: 4249 Revision: 4
Authority: Technical Leader	Page: 3 of 4
Original maintained by Quality Programs; copies are uncontrolled.	

### **RANDOM UNCERTAINTY**

The random uncertainty,  $U_R$ , is determined from random errors that occur naturally during operation. The errors are determined using sample measurements taken during typical test conditions. The random uncertainty is calculated by applying the standard deviation,  $S$ , and the number of measurements,  $n$ , in a sample to Equation 1.2.

$$U_R = \frac{S}{\sqrt{n}} \quad (1.2)$$

The random uncertainty is based on a sample containing 600 measurements of a 22.7 kg (50 lb<sub>m</sub>) mass. The random uncertainty for the weighing device is  $\pm 0.0002$  kg (0.0004 lb<sub>m</sub>) or 0.00% of a 30 kg capacity.

### **COMBINED UNCERTAINTY**

The combined uncertainty,  $U_C$ , is determined from the combining the allowable uncertainty and random uncertainty in quadrature. The combined uncertainty is calculated using Equation 1.3.

$$U_C = \sqrt{(U_A^2 + U_R^2)} \quad (1.3)$$

The combined uncertainty for the Sartorius-Scale-30 kg weighing device is  $\pm 0.0112$  kg (0.0247 lb<sub>m</sub>) or  $\pm 0.04\%$  of a 30 kg capacity.

## **References**

1. Taylor, B. N., & Kuyatt, C. E., "NIST Technical Note 1297: Guidelines for Evaluating and Expressing the Uncertainty of NIST Measurement Results," National Institute of Standards and Technology, Gaithersburg, MD, 1993.
2. Bryant, A.R., Ohlemiller, T.J., Johnsson, E.L, Hamins, A., Grove, B.S., Guthrie, W.F., Maranghides, A., Mulholland, G.W., "Special Publication 1007," National Institute of Standards and Technology, Gaithersburg, MD, 2003.
3. Guthrie, W. & Liu, H., "Hands-on Workshop on Estimating and Reporting Measurement Uncertainty," National Institute of Standards and Technology, Presentation given to CPSC, 2007.
4. "Service Manual Sartorius Combics 1 Combics 2", Publication Number WCI5005-e03104, Sartorius AG, Goettingen, Germany, October 2003



ATF-LS-FRL-TR019I Sartorius Scale-30 kg - Technical Reference	ID: 4249 Revision: 4
Authority: Technical Leader	Page: 4 of 4
Original maintained by Quality Programs; copies are uncontrolled.	

5. "Handbook 44: Specifications, Tolerances, and Other Technical Requirements for Weighing Devices," National Institute of Standards and Technology, Gaithersburg, MD, 2010.



ATF-LS-FRL-TR019J Sartorius Scale-150 kg - Technical Reference	ID: 4250 Revision: 4
Authority: Technical Leader	Page: 1 of 3
Original maintained by Quality Programs; copies are uncontrolled.	

## Scope

This Technical Reference covers the use, design and specifications of the Sartorius-Scale-150 kg scale used in the Bureau of Alcohol, Tobacco, Firearms and Explosives (ATF) Fire Research Laboratory (FRL).

## Instrument Description

### **GENERAL**

The Sartorius-Scale-150 kg weighing device is used primarily for mass measurements up to a capacity of 150 kg (300 lb<sub>m</sub>). This scale offers a modular design incorporating the use of a load cell, a weighing platform, and an indicator unit. The components of Sartorius-Scale-150 kg weighing device are calibrated as one unit in accordance with manufacturer and ATF specifications.

### Load Cell

The Sartorius-Scale-150 kg uses one load cell (model 03167124) with a capacity of 150 kg (300 lb<sub>m</sub>). The load cell responds to an applied load positioned on a weighing platform and relays an electrical response to a junction box with amplifier. The electrical signal is then transmitted to the indicator unit.

### Weighing Platform

The Sartorius-Scale-150 kg uses a Sartorius model CAPP1U-250GG-LU weighing platform with a 61 cm x 61 cm (24 inch x 24 inch) stainless steel load plate. The platform is NEM4/IP65 to withstand everyday washdown environments. The platform must be leveled manually by the user prior to testing to reduce measurement errors caused by the angular orientation of the scale. Adjusting the supports on each of the corners of the weighing platform raises or lowers each corner if the scale is used on an uneven surface.

### Indicator

The Sartorius-Scale-150 kg uses a Sartorius Combics 2 Model CAIS2-U indicator unit to provide a digital display of the analog electrical output signal from the load cell. The indicator offers a maximum readability of 0.005 kg (0.01 lb<sub>m</sub>) at a 150 kg (300 lb<sub>m</sub>) capacity. The indicator also contains functions that zero, tare, and offset mass measurements to the full capacity defined by the indicator.

## **CONNECTING TO THE DATA ACQUISITION**

The Sartorius Combics 2 indicator allows for transmitting data to the data acquisition (DAQ) system by means of a network cable connected to a FireTOSS jack.



ATF-LS-FRL-TR019J Sartorius Scale-150 kg - Technical Reference	ID: 4250 Revision: 4
Authority: Technical Leader	Page: 2 of 3
Original maintained by Quality Programs; copies are uncontrolled.	

## Uncertainty

The uncertainty of the mass measurements was estimated using the guidelines of the National Institute of Standards and Technology (NIST) Technical Note 1297 [1], Special Publication 1007 [2], and the NIST Uncertainty Workshop [3]. The uncertainty of mass measurements includes the allowable uncertainty, random uncertainty, and combined uncertainty.

### **ALLOWABLE UNCERTAINTY**

The allowable uncertainty is determined from allowable tolerances provided in the manufacturer's specifications and NIST Handbook 44. The allowable tolerances defined by the manufacturer [4] are:

- the linearity as  $\pm 0.0227$  kg (0.05 lb<sub>m</sub>)
- the span as  $\pm 0.0454$  kg (0.1 lb<sub>m</sub>)
- the off-center load eccentricity as  $\pm 0.0454$  kg (0.1 lb<sub>m</sub>)
- the reproducibility as  $\pm 0.0227$  kg (0.05 lb<sub>m</sub>)

Additional tolerance requirements for the weighing device provided by NIST Handbook 44 [5] are:

- the tolerance as  $\pm 0.0100$  kg (0.0220 lb<sub>m</sub>)
- the zero balance as  $\pm 0.0750$  kg (0.165 lb<sub>m</sub>)
- the sensitivity as  $\pm 0.0040$  kg (0.009 lb<sub>m</sub>)
- the temperature effect on the minimum dead load output as  $\pm 0.0020$  kg (0.004 lb<sub>m</sub>) over a temperature change of 5°C (9°F)

The error associated with each tolerance,  $T$ , assumes a rectangular probably distribution and can be calculated by dividing the tolerance by  $\sqrt{3}$  [1]. The allowable uncertainty,  $U_A$ , can be calculated by combining the error components in quadrature using Equation 1.1.

$$U_A = \sqrt{\sum \left(\frac{T}{\sqrt{3}}\right)^2} \quad (1.1)$$

The allowable uncertainty for the weighing device is  $\pm 0.0607$  kg (0.114 lb<sub>m</sub>) or  $\pm 0.002\%$  of a 150 kg capacity.



ATF-LS-FRL-TR019J Sartorius Scale-150 kg - Technical Reference	ID: 4250 Revision: 4
Authority: Technical Leader	Page: 3 of 3
Original maintained by Quality Programs; copies are uncontrolled.	

### **RANDOM UNCERTAINTY**

The random uncertainty,  $U_R$ , is determined from random errors that occur naturally during operation. The errors are determined using sample measurements taken during typical test conditions. The random uncertainty is calculated by applying the standard deviation,  $S$ , and the number of measurements,  $n$ , in a sample to Equation 1.2.

$$U_R = \frac{S}{\sqrt{n}} \quad (1.2)$$

The random uncertainty is based on a sample containing 600 measurements of a 90.7 kg (200 lb<sub>m</sub>) mass. The random uncertainty for the weighing device is  $\pm 0.00$  kg (0.00 lb<sub>m</sub>) or 0 % of a 150 kg capacity.

### **COMBINED UNCERTAINTY**

The combined uncertainty,  $U_C$ , is determined from the combining the allowable uncertainty and random uncertainty in quadrature. The combined uncertainty is calculated using Equation 1.3.

$$U_C = \sqrt{(U_A^2 + U_R^2)} \quad (1.3)$$

The combined standard uncertainty for the Sartorius-Scale-150 kg is  $\pm 0.0607$  kg (0.114 lb<sub>m</sub>) or  $\pm 0.002$  % of a 150 kg capacity.

### **References**

1. Taylor, B. N., & Kuyatt, C. E., "NIST Technical Note 1297: Guidelines for Evaluating and Expressing the Uncertainty of NIST Measurement Results," National Institute of Standards and Technology, Gaithersburg, MD, 1993.
2. Bryant, A.R., Ohlemiller, T.J., Johnsson, E.L, Hamins, A., Grove, B.S., Guthrie, W.F., Maranghides, A., Mulholland, G.W., "Special Publication 1007," National Institute of Standards and Technology, Gaithersburg, MD, 2003.
3. Guthrie, W. & Liu, H., "Hands-on Workshop on Estimating and Reporting Measurement Uncertainty," National Institute of Standards and Technology, Presentation given to CPSC, 2007.
4. "Service Manual Sartorius Combiics 1 Combiics 2", Publication Number WCI5005-e03104, Sartorius AG, Goettingen, Germany, October 2003
5. "Handbook 44: Specifications, Tolerances, and Other Technical Requirements for Weighing Devices," National Institute of Standards and Technology, Gaithersburg, MD, 2010.